



hmi

high-accuracy
measurement
instruments

FICHA TÉCNICA DE PRODUTO

PRODUCT DATASHEET

HMI – Automação e Instrumentação, Lda.

Travessa da Indústria, nº 111
4780-573 Santo Tirso
PORTUGAL

Tel. +351 252 850 501
Fax. +351 300 013 487

Web: www.hmi.pt

Email: hmi@hmi.pt

Endura AZ20 series probe

Combustion oxygen monitor



Measurement made easy

— Superior technology and quality from the world leader in oxygen measurement

Introduction

The Endura AZ20 is the latest in a long line of high-quality, combustion gas analyzers from ABB.

The sensor, based on a zirconium oxide cell, is mounted at the tip of the probe that is inserted in the flue duct. The resulting direct, in situ measurement provides accurate and rapid oxygen reading for combustion control / optimization and emissions monitoring purposes.

Endura AZ20 has been designed for extended periods of maintenance-free operation. The modular design with reduced component count improves the reliability and robustness of the system and simplifies breakdown repair if it occurs.

Kits containing all the parts needed to complete on-site repairs are available from ABB, ensuring that service personnel can effect repairs quickly and efficiently at minimum cost. The Endura AZ20 probe has retained an easy-access cell arrangement, similar to the proven ZFG2 probe. This ensures cell replacement can be carried out on-site using readily available, basic hand tools, even after long periods of high temperature operation.

This User Guide should be used in conjunction with the following publications:

- Transmitter User Guide ([IM/AZ20E-EN](#))
- Maintenance Guide ([IM/AZ20M-EN](#)).

For more information

Further publications for the Endura AZ20 probe are available for free download from:

www.abb.com/measurement

or by scanning this code:



Search for or click on

Data Sheet
Endura AZ20 oxygen monitor
Combustion gas analysis [DS/AZ20-EN](#)

User Guide
Endura AZ20 series probe
Combustion oxygen monitor [IM/AZ20P-EN](#)

Maintenance Guide
Endura AZ20 series probe
Combustion oxygen monitor [IM/AZ20M-EN](#)

Addendum
RoHS Directive 2011/65/EU (RoHS II) [ADD/MEASUREMENT/001-EN](#)

1 Safety

Information in this manual is intended only to assist our customers in the efficient operation of our equipment. Use of this manual for any other purpose is specifically prohibited and its contents are not to be reproduced in full or part without prior approval of the Technical Publications Department.

1.1 Health & Safety

Health and Safety

To ensure that our products are safe and without risk to health, the following points must be noted:

- The relevant sections of these instructions must be read carefully before proceeding.
- Warning labels on containers and packages must be observed.
- Installation, operation, maintenance and servicing must only be carried out by suitably trained personnel and in accordance with the information given.
- Normal safety precautions must be taken to avoid the possibility of an accident occurring when operating in conditions of high pressure and / or temperature.
- Chemicals must be stored away from heat, protected from temperature extremes and powders kept dry. Normal safe handling procedures must be used.
- When disposing of chemicals ensure that no two chemicals are mixed.

Safety advice concerning the use of the equipment described in this manual or any relevant Material Safety Data Sheets (where applicable) may be obtained from the Company address on the back cover, together with servicing and spares information.









1.2 Electrical Safety – CEI / IEC 61010-1:2001-2







This equipment complies with the requirements of CEI / IEC 61010-1:2001-2 'Safety Requirements for Electrical Equipment for Measurement, Control and Laboratory Use' and complies with US NEC 500, NIST and OSHA.

If the equipment is used in a manner NOT specified by the Company, the protection provided by the equipment may be impaired.

1.3 Symbols – CEI / IEC 61010-1:2001-2

One or more of the following symbols may appear on the equipment labelling:

	Protective earth (ground) terminal.
	Functional earth (ground) terminal.
	Direct current supply only.
	Alternating current supply only.
	Both direct and alternating current supply.
	The equipment is protected through double insulation.
	This symbol, when noted on a product, indicates a potential hazard which could cause serious personal injury and / or death. The user should reference this instruction manual for operation and / or safety information.
	This symbol, when noted on a product enclosure or barrier, indicates that a risk of electrical shock and / or electrocution exists and indicates that only individuals qualified to work with hazardous voltages should open the enclosure or remove the barrier.
	This symbol indicates that the marked item can be hot and should not be touched without care.

	This symbol indicates the presence of devices sensitive to electrostatic discharge and indicates that care must be taken to prevent damage to them.
	This symbol identifies a risk of chemical harm and indicates that only individuals qualified and trained to work with chemicals should handle chemicals or perform maintenance on chemical delivery systems associated with the equipment.
	This symbol indicates the need for protective eye wear.
	This symbol indicates the need for protective hand wear.
	Electrical equipment marked with this symbol may not be disposed of in European public disposal systems. In conformity with European local and national regulations, European electrical equipment users must now return old or end-of-life equipment to the manufacturer for disposal at no charge to the user.
	Products marked with this symbol indicates that the product contains toxic or hazardous substances or elements. The number inside the symbol indicates the environmental protection use period in years.

1.4 Product Recycling Information

	Electrical equipment marked with this symbol may not be disposed of in European public disposal systems after 12 August 2005. In conformity with European local and national regulations (EU Directive 2002 / 96 / EC), European electrical equipment users must now return old or end-of-life equipment to the manufacturer for disposal at no charge to the user.
---	---

Note. For return for recycling, please contact the equipment manufacturer or supplier for instructions on how to return end-of-life equipment for proper disposal.

1.5 Product Disposal

Note. The following only applies to European customers.

	<p>ABB is committed to ensuring that the risk of any environmental damage or pollution caused by any of its products is minimized as far as possible. The European Waste Electrical and Electronic Equipment (WEEE) Directive (2002 / 96 / EC) that came into force on August 13 2005 aims to reduce the waste arising from electrical and electronic equipment; and improve the environmental performance of all those involved in the life cycle of electrical and electronic equipment.</p> <p>In conformity with European local and national regulations (EU Directive 2002 / 96 / EC stated above), electrical equipment marked with the above symbol may not be disposed of in European public disposal systems after 12 August 2005.</p>
---	---

1.6 Restriction of Hazardous Substances (RoHS)

	<p>The European Union RoHS Directive and subsequent regulations introduced in member states and other countries limits the use of six hazardous substances used in the manufacturing of electrical and electronic equipment. Currently, monitoring and control instruments do not fall within the scope of the RoHS Directive, however ABB has taken the decision to adopt the recommendations in the Directive as the target for all future product design and component purchasing. .</p>
--	---

1.7 Safety Precautions

Please read the entire manual before unpacking, setting up, or operating this instrument.

Pay particular attention to all warning and caution statements. Failure to do so could result in serious injury to the operator or damage to the equipment.

To ensure the protection provided by this equipment is not impaired, do not use or install this equipment in any manner other than that which is specified in this manual.

1.8 Safety Conventions

Warning. In this manual, a warning is used to indicate a condition which, if not met, could cause serious personal injury and / or death. Do not move beyond a warning until all conditions have been met.

If a warning sign appears on the instrument itself, refer to Precautionary Labels – UL Certification and Electrical Safety – CEI / IEC 61010-1:2001-2 for an explanation.

Caution. A caution is used to indicate a condition which, if not met, could cause minor or moderate personal injury and / or damage to the equipment. Do not move beyond a caution until all conditions have been met.

Note. A note is used to indicate important information or instructions that should be considered before operating the equipment.

1.9 Safety Recommendations

For safe operation, it is imperative that these service instructions be read before use and that the safety recommendations mentioned herein be scrupulously respected. If danger warnings are not heeded to, serious material or bodily injury could occur.

Warning. The installation of the instrument should be performed exclusively by personnel specialized and authorized to work on electrical installations, in accordance with relevant local regulations.

1.10 Service and Repairs

Other than the serviceable items listed in Appendix D, page 36, none of the instrument's components can be serviced by the user. Only personnel from ABB or its approved representative(s) is (are) authorized to attempt repairs to the system and only components formally approved by the manufacturer should be used. Any attempt at repairing the instrument in contravention of these principles could cause damage to the instrument and corporal injury to the person carrying out the repair. It renders the warranty null and void and could compromise the correct working of the instrument and the electrical integrity or the CE compliance of the instrument.

If you have any problems with installation, starting, or using the instrument please contact the company that sold it to you. If this is not possible, or if the results of this approach are not satisfactory, please contact the manufacturer's Customer Service

1.11 Potential Safety Hazards

The following potential safety hazards are associated with operating the system:

- Electrical (line voltage)
- Probe weight

2 System Overview

This User Guide provides the following information:

- schematics for systems fitted with or without restrictors (including test gas and reference air requirements) – see section 3.3, page 6 for product identification
- installation details for integral and remote Endura AZ20 probes – see section 3, page 6
- electrical connection details:
 - for standard probe connection details (without automatic calibration [AutoCal]) between a remote Endura AZ20 probe and a remote Endura AZ20 transmitter – see section 4.3.1, page 20
 - for automatic calibration connection details between a remote Endura AZ20 probe and a remote Endura AZ20 transmitter – see section 4.3.2, page 21
- electrical connection details between an existing ZDT analyzer or ZMT transmitter and a remote Endura AZ20/ZFG2 replacement probe (where the Endura AZ20/ZFG2 replacement probe replaces an existing ZFG2 probe)
 - refer to appendix B.2, page 33 for ZDT-FG connections
 - refer to appendix B.3, page 34 for ZMT connections

Warning.

- System configuration must be carried out only by users or personnel with approved access rights (user privileges).
- Read all relevant sections of this guide before configuring the system or modifying system parameters.
- Install and use this equipment as detailed in this guide. Install and use associated equipment in accordance with the relevant national and local standards.

The Endura AZ20 oxygen probe measures oxygen concentration in flue gas using an in situ 'wet analysis' method. The 'wet analysis' method avoids measurement error (typically 20% of reading higher than the actual value) that is introduced by a sampling system using the 'dry analysis' method.

For customers with an existing installed ZFG2 probe with a ZMT or ZDT transmitter, a 55 V heater version of the Endura AZ20 probe (the Endura AZ20 / ZFG2 replacement probe) is available.

System equipment comprises a (flue-mounted) Endura AZ20 probe controlled by an integral or remote transmitter. During operation, a zirconia cell within the probe is held at a constant temperature of 700°C (1292 °F) by a probe heater and control thermocouple assembly. If the heater control circuitry or software fails (unsafe), the probe heater power supply is switched off, ensuring the system fails 'safe' and protects the heater from an over-temp failure.

An output generated at the zirconia cell is processed in the transmitter giving a locally displayed O₂ reading and a 4 to 20 mA retransmission signal over any range between 0 % and 100 % O₂.

Optional automatic calibration (AutoCal*) enables automatic, semi-automatic or manual calibration to be performed using a probe-mounted gas control manifold mounted within the probe head. Calibration sequencing is software-controlled from the transmitter.

Optional restrictors (where fitted*) in the probe head control the test gas and reference air flow without the need for flowmeters. The probe requires only preset test gas and reference air pressures of 1 bar (15 psi) to maintain a constant flow of 2.2 l / min (4.662 scfh). This flow is not affected by changes in the measured gas pressure of ± 0.35 bar (5 psi).

Warning. Endura AZ20 probes must be connected only to an integral or remote Endura AZ20 transmitter (AZ20XX1 or 2).
Endura AZ20/ZFG2 replacement probes (AZ200002) must be connected only to a ZDT-FG or ZMT transmitter.

*Not available for Endura AZ20/ZFG2 replacement probes.

3 Mechanical Installation

3.1 General Installation Requirements

Warning.

- Before installing the probe, check the probe data and the alteration labels on the head of the probe – see Section 3.3.
- Select a location away from strong electrical and magnetic fields. If this is not possible, particularly in applications where mobile communications equipment is expected to be used, screened cables within flexible, earthed metal conduit must be used.
- Before installing the probe, read the Safety notes in Section 1.
- Ensure suitable lifting equipment and qualified personnel are available to suit the probe length being installed – see page 16 for probe weights.

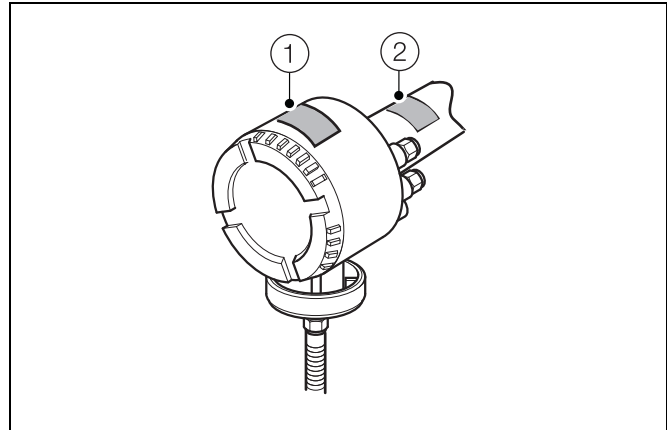

Fig. 3.1 Location of Probe Labels

3.2 Unpacking

Caution. Visually inspect equipment for damage before installing. Do not install damaged or faulty equipment.

Warning.

- Handle the probe with care and do not subject it to hammer blows or other sharp shocks. The probe inners have fragile ceramic components that can be damaged.
- It is recommended to retain the protective probe packing materials to allow for re-shipping in the unlikely event of a return.

3.3 Identifying the Probe

Each probe is identified by 2 probe-specific labels attached to the probe head (separate transmitter-specific labels are also attached to each system transmitter).

Caution. Details on the probe labels are unique to the cell / probe combination they are attached to and **cannot** be used to identify any other probe or system.

The probe labels comprise:

- ① Data Label – used to identify the probe code (A), probe serial number (B), probe power rating (C) and approval symbols (D) (if applicable).

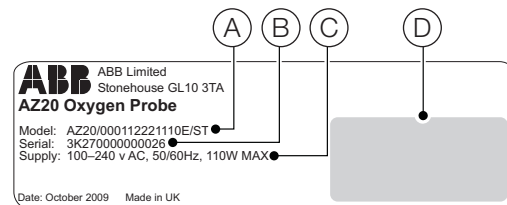

- ② Commissioning Label – contains the cell number (A), date (B), cell zero (C) and the calibration factor value (D) required to calibrate the probe for the zirconia cell fitted – see IM/AZ20E-EN for commissioning procedures.

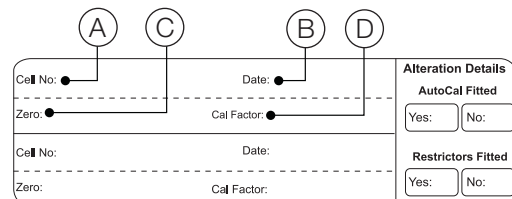

The Commissioning Label also indicates if automatic calibration and / or restrictors have been added. If either item has been added, the information on this label overrides some of the product code on the Data Label ①.

3.4 Siting

Avoid locations where:

- obstructions or bends create turbulence in the gas flow and / or hinder probe insertion and removal
- vibration induced by other plant or vortex shedding is present
- the probe may be subject to shock loading, for example, close to ash hammers

If excessive abrasive dust is present, fit a protective shield along the whole length of the inserted probe section.

If liquid condensation is present or could be created (for example a cold start on a gas boiler), mount the probe at a downward angle to prevent water entering the cell.

If necessary, thermally lag the probe mounting flange and body to prevent acid dew-point corrosion and to maintain the probe head temperature within the range of -20 to 70 °C (4 to 176 °F).

3.4.1 System Overview

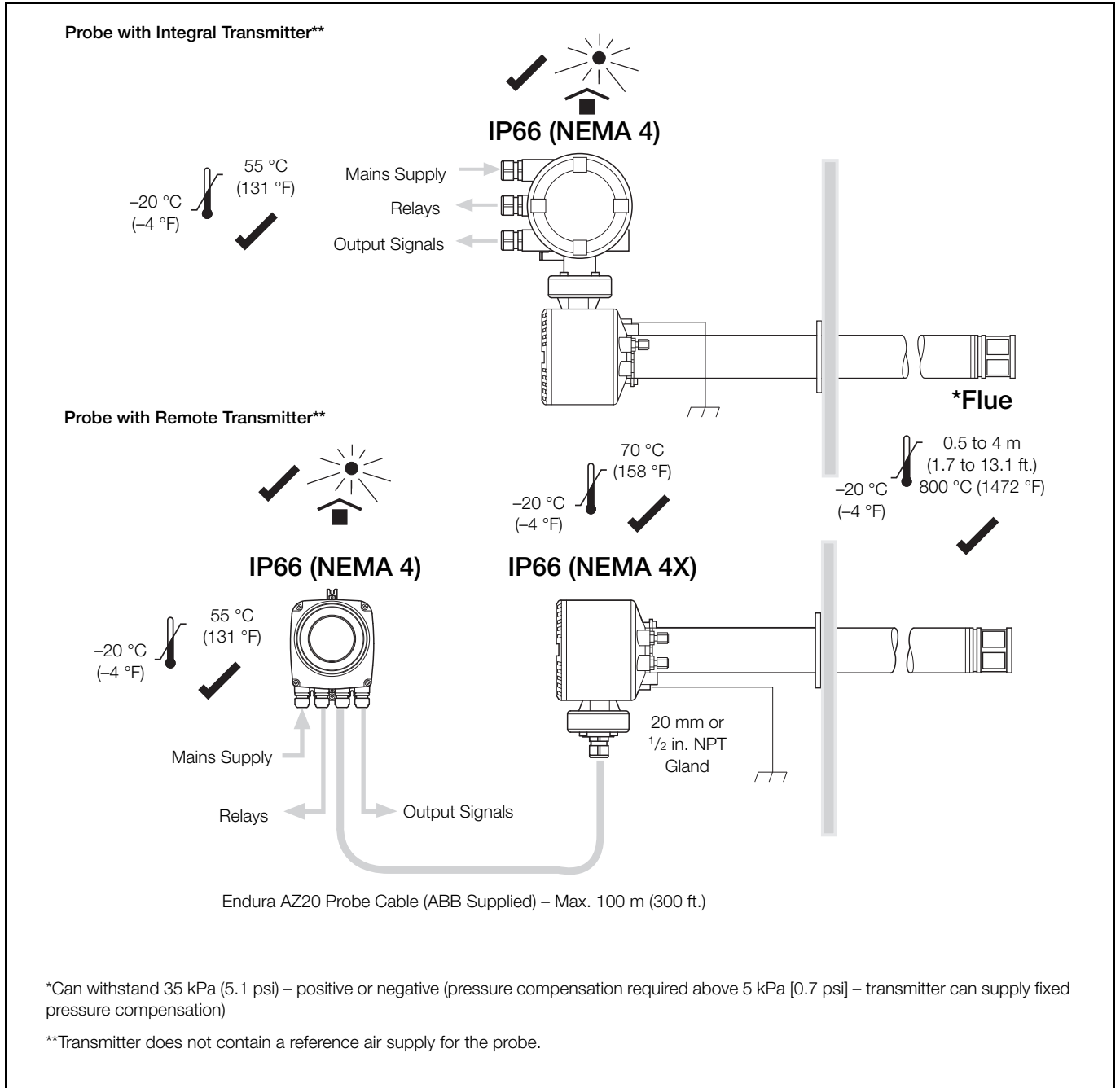

Fig. 3.2 Probe and Transmitter Temperature / Environmental Limits and Power Input / Output Supplies

3.5 Pneumatic Connections

Caution.

- The configuration option of having flow restrictors fitted to the probe determines the way the reference air and test gas flow is controlled. Ensure the instructions for the pneumatic connections are followed accurately – an incorrect configuration at the probe can cause errors and / or permanent damage.
- **All configurations** – do not use gas mixers online to supply test gases to the probe(s) unless it can be confirmed that errors are not introduced by the high delivery pressures required to the probe(s).
- **Probes with restrictors** – the reference air and test gas flow is regulated by the restrictors installed in the probe which require a set pressure of 1 bar (15 psi) to deliver the correct flows. Because the gases are delivered as a pressure at the probe it is permissible to use parallel pipework for multiple-probe installations.
- **Probes without restrictors** – the reference air and test gas flow is regulated by flowmeters (with integral needle valves) fitted in the delivery lines to the sensor – one flowmeter is required in **each** delivery line.

3.5.1 Pneumatic Connection Configurations

Refer to the pneumatic configuration flowchart (Fig. 3.3) below to identify which system configuration is the closest match for your components and then refer to the relevant figure in Section 3.5.2, page 9 or 3.5.3, page 10 for pneumatic settings.

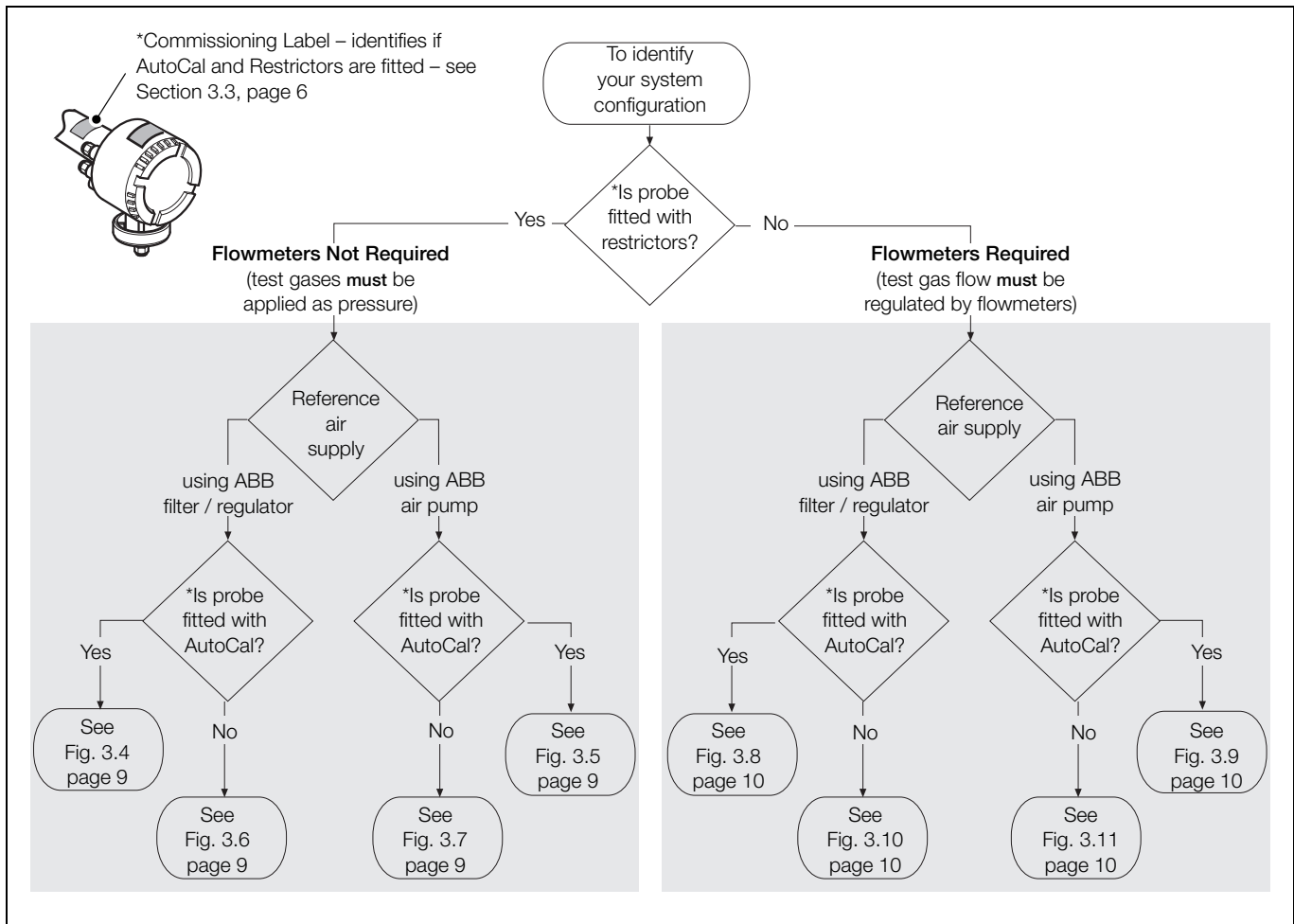

Fig. 3.3 Pneumatic Connection Configurations (Schematic)

3.5.2 Pneumatic Connections for Probes with Restrictors

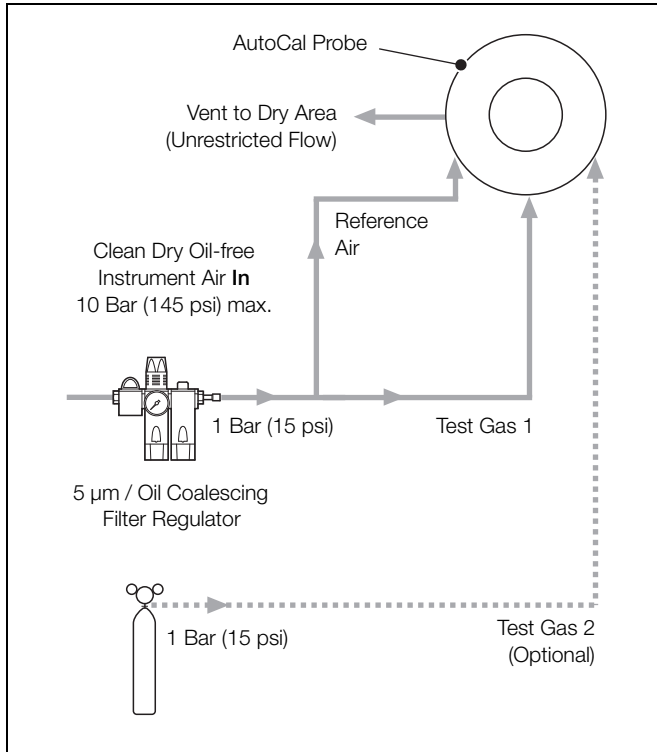

Fig. 3.4 AutoCal with Test Gas Air and Optional Certified Test Gas

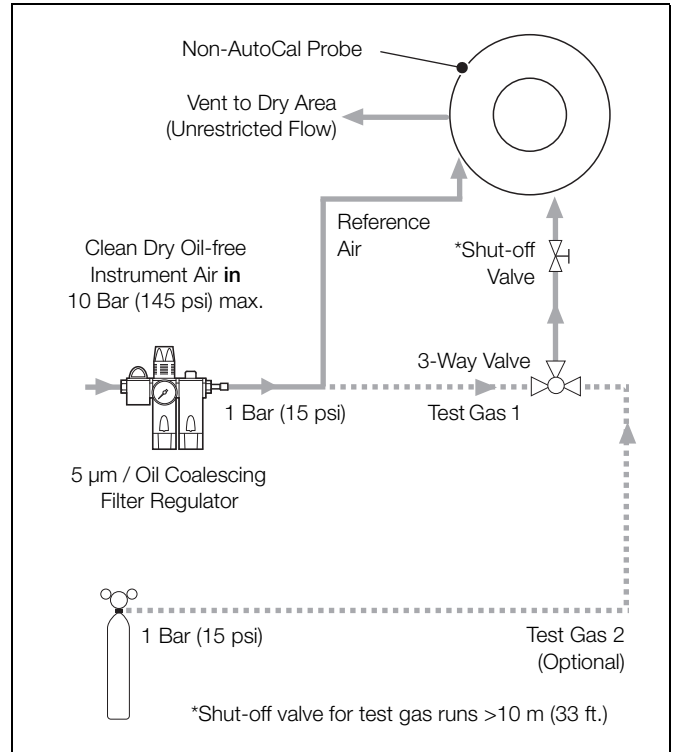

Fig. 3.6 Non-AutoCal with Test Gas Air and Optional Certified Test Gas

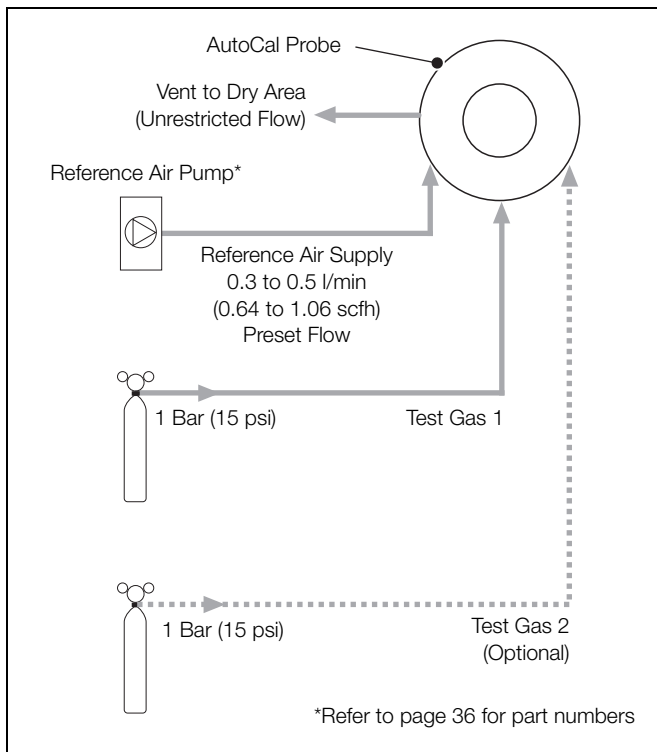

Fig. 3.5 AutoCal with 2 Certified Test Gases

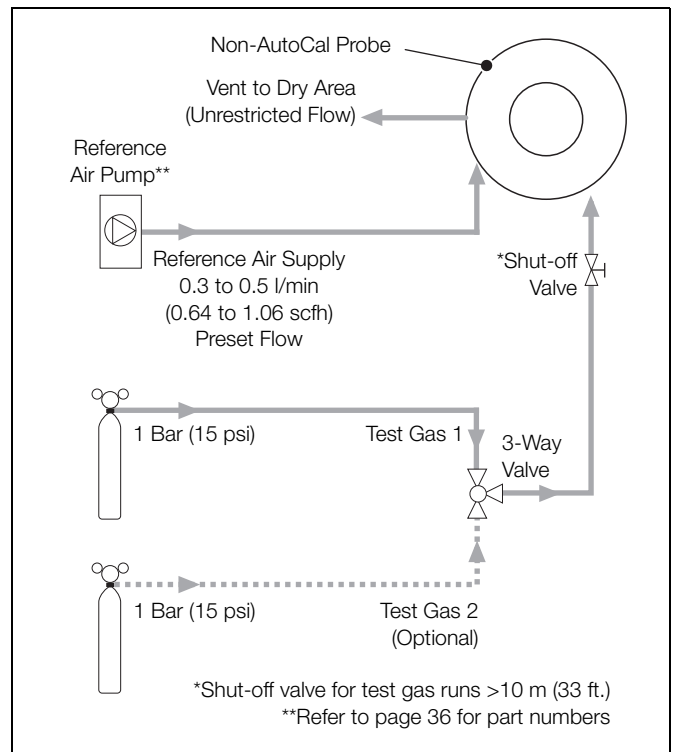

Fig. 3.7 Non-AutoCal with 2 Certified Test Gases

3.5.3 Pneumatic Connections for Probes without Restrictors

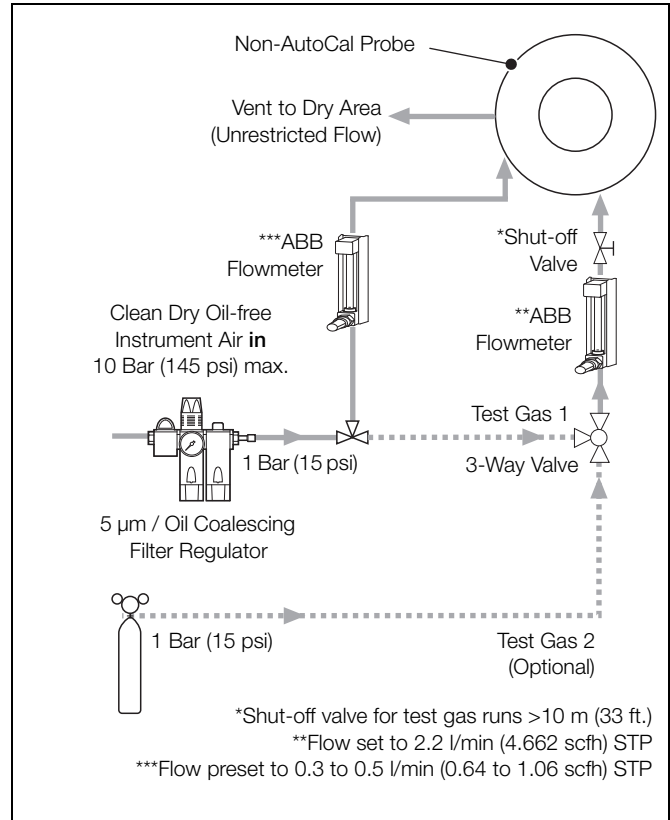
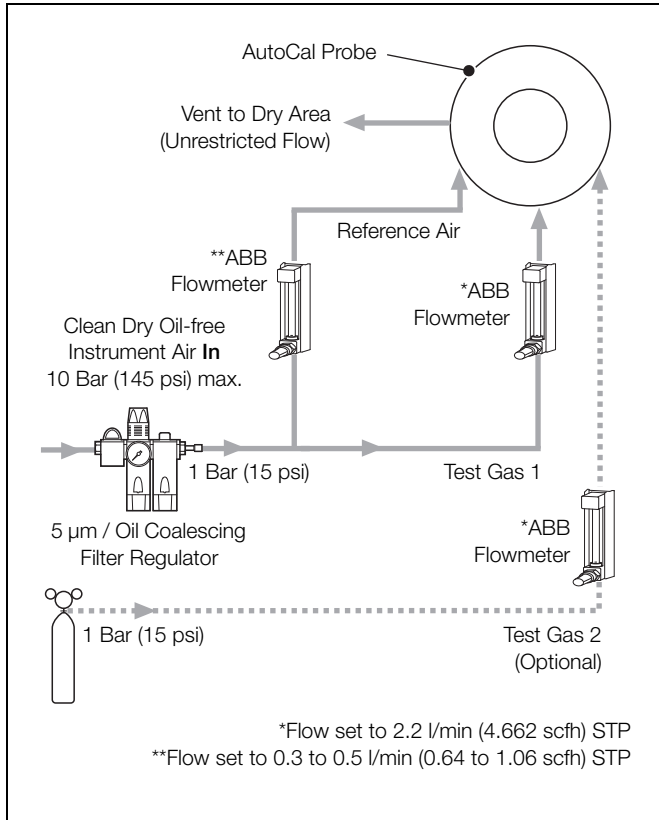

Fig. 3.8 AutoCal with Test Gas Air and Optional Certified Test Gas

Fig. 3.10 Non-AutoCal with Test Gas Air and Optional Certified Test Gas

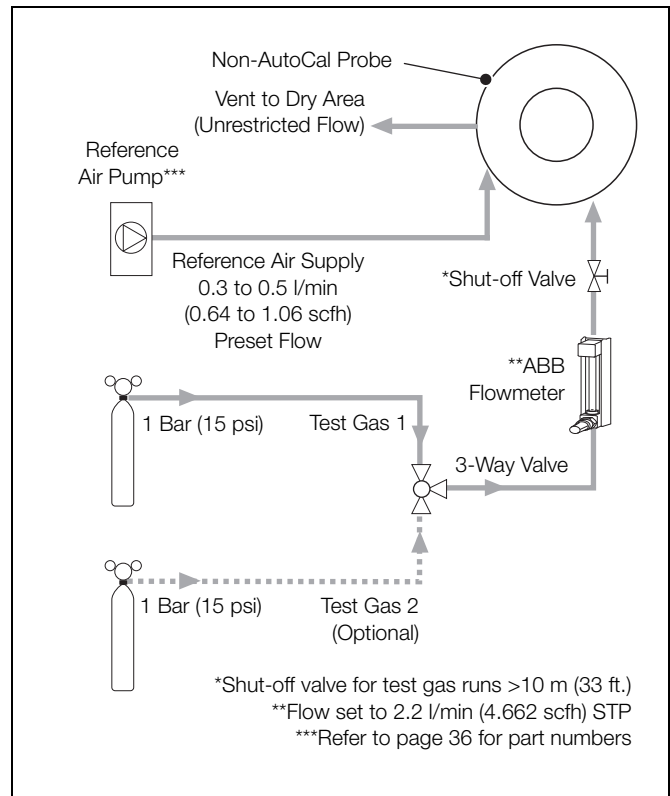
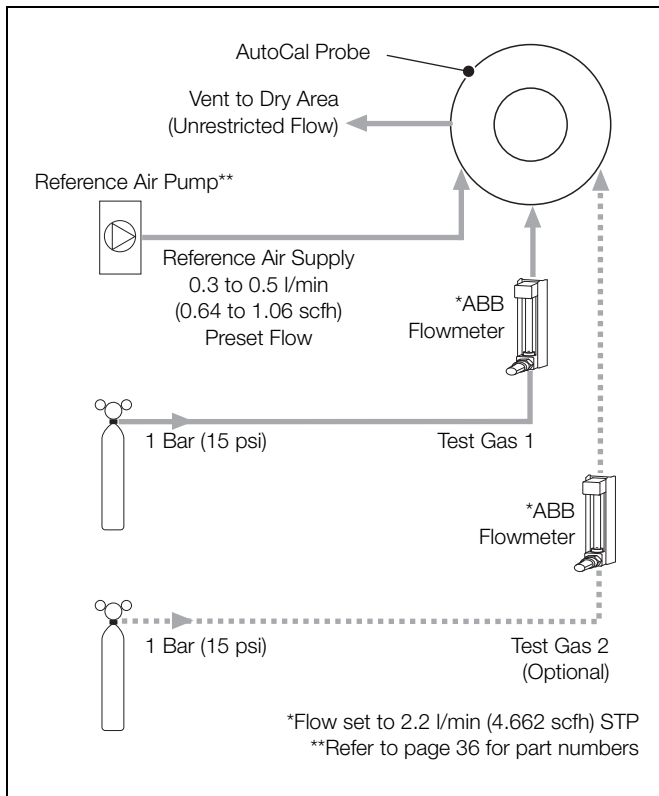

Fig. 3.9 AutoCal with 2 Certified Test Gases

Fig. 3.11 Non-AutoCal with 2 Certified Test Gases

3.6 Overall Dimensions

3.6.1 Remote Endura AZ20 Probe

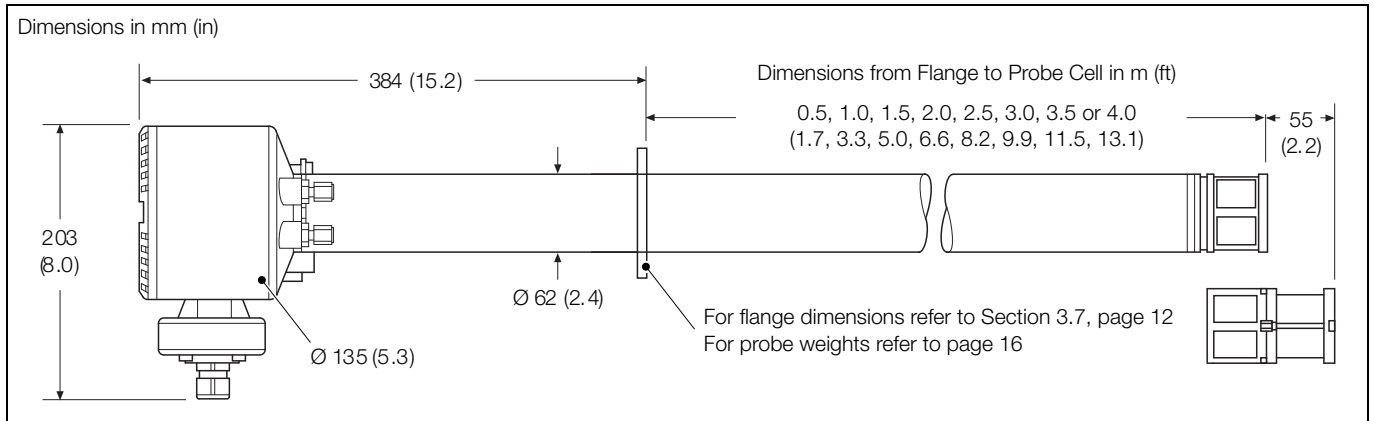

Fig. 3.12 Overall Dimensions – Remote Endura AZ20 Probe

3.6.2 Integral Endura AZ20 Probe

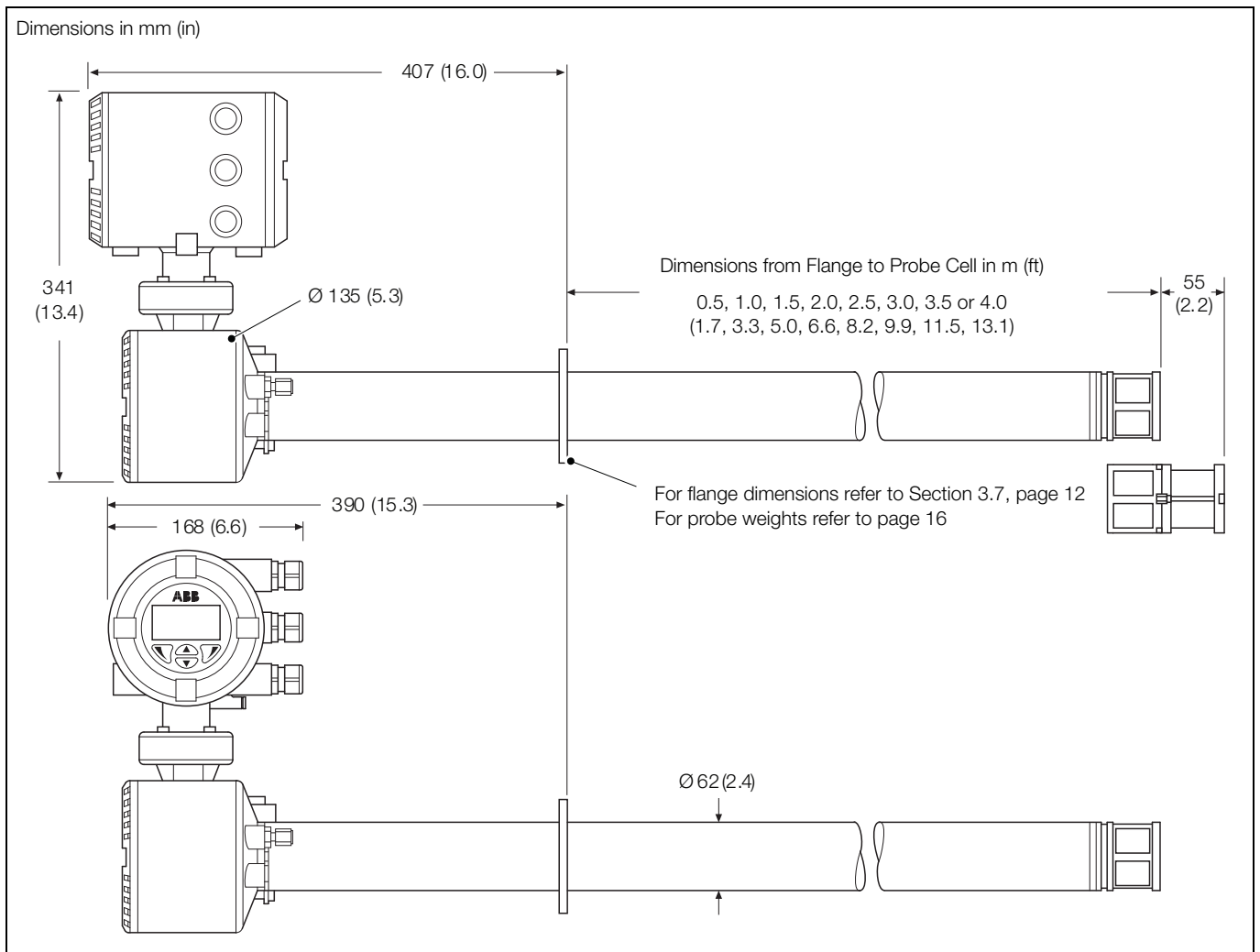

Fig. 3.13 Overall Dimensions – Integral Endura AZ20 Probe

3.7 Endura AZ20 Probe Flanges – All Probe Lengths

Note. These flanges are not pressure rated.

Dimensions in mm (in).

Flange Type	A	B	C (Ø)	D (PCD)	4-Hole Flanges
ANSI 2 in 150	152.4 (6.00)	12 (0.47)	19 (0.75)	120.6 (4.75)	
ANSI 2.5 in 150	177.8 (7.00)	12 (0.47)	19 (0.75)	139.7 (5.50)	
ANSI 3 in 150	190.5 (7.50)	12 (0.47)	19 (0.75)	152.4 (6.00)	
DIN 65 PN16	185 (7.28)	12 (0.47)	18 (0.70)	145 (5.70)	
JIS 65 5K	155 (6.10)	12 (0.47)	15 (0.59)	130 (5.12)	
JIS 80 5K	180 (7.08)	12 (0.47)	19 (0.75)	145 (5.71)	

Table 3.1 4-Hole Probe Flange Types and Dimensions

Flange Type	A	B	C (Ø)	D (PCD)	6-Hole Flanges
ABB Standard (0.5 m [1.64 ft.] probes only)	101 (3.97)	6 (0.24)	7.3 (0.29)	80 (3.15)	
ABB Standard	165 (6.50)	12 (0.47)	12.5 (0.50)	140 (5.51)	

Table 3.2 6-Hole Probe Flange Types and Dimensions

Flange Type	A	B	C (Ø)	D (PCD)	8-Hole Flanges
ANSI 4 in 150	228.6 (9.0)	12 (0.47)	19 (0.75)	190.5 (7.50)	
DIN 80 PN16	200 (7.87)	12 (0.47)	18 (0.70)	160 (6.30)	
DIN 100 PN16	220 (8.66)	12 (0.47)	18 (0.70)	180 (7.08)	
JIS 100 5K	200 (7.87)	12 (0.47)	19 (0.75)	165 (6.50)	

Table 3.3 8-Hole Probe Flange Types and Dimensions

3.8 Mounting Plates for ABB Standard Flanges

In addition to the probe flange, the probe can be supplied with a mounting plate assembly for use with ABB Standard flanges (see Table 3.2, page 12) if specified.

Note. A mounting plate is required if there is no existing mounting on the flue or boiler.

3.8.1 0.5 m (1.7 ft) Probe – Part No. AZ200 796

The 0.5 m (1.7 ft) probe mounting plate comprises the following items:

- probe mounting plate
- probe mounting gasket
- 6 x M6 shakeproof washers
- 6 x M6 plain washers
- 6 x M6 nuts

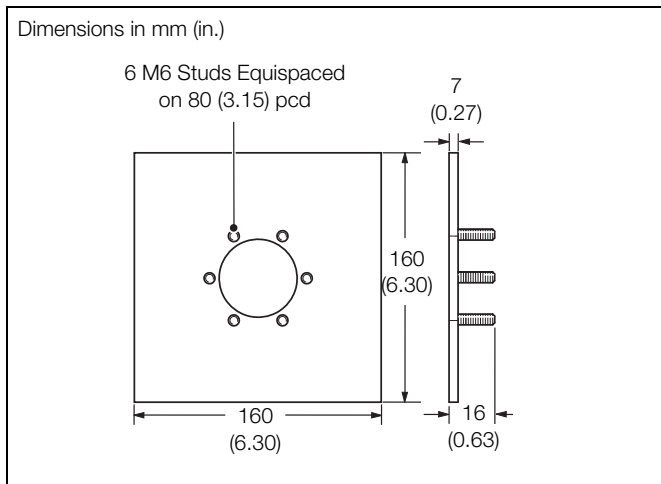

Fig. 3.14 Standard Mounting Plate – 0.5 m (1.7 ft) Probe

3.8.2 1.0 to 4.0 m (3.3 to 13.1 ft) Probes – Part No. AZ200 795

The 1.0 to 4.0 m (3.3 to 13.1 ft) probe mounting plates comprise the following items:

- probe mounting plate
- probe mounting gasket
- 6 x M10 shakeproof washers
- 6 x M10 plain washers
- 6 x M10 nuts

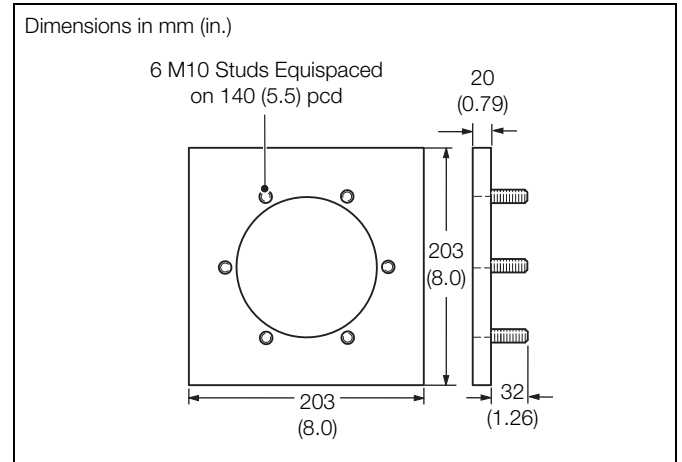

Fig. 3.15 Standard Mounting Plate – 1.0 to 4.0 m (3.3 to 13.1 ft) Probes

3.8.3 Long Probe to 0.5 m (1.7 ft) Probe Adaptor Plate – Part No. AZ200 794

The Long Probe to 0.5 m (1.7 ft) Probe Adaptor Plate comprises the following items:

- probe mounting plate
- probe adaptor gasket
- probe mounting gasket
- 6 x M6x16 hexagon-head steel screws
- 6 x M6 shakeproof washers

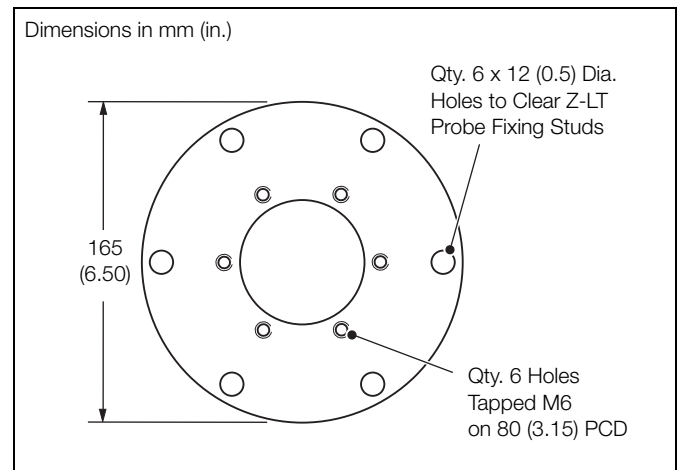

Fig. 3.16 Long Probe to 0.5 m (1.7 ft) Probes Adaptor Plate

3.9 Mounting

Note. Mount integral probes with the transmitter at the top of the probe head. Mount remote probes with the conduit at the bottom of the probe head.

3.9.1 Probe

To mount the probe (all sizes):

1. Cut a 120 mm (4.72 in) diameter hole in the flue wall (A).
2. Either:
 - a. weld the mounting plate (B) into place, concentric with the hole in the flue
 - or**
 - b. drill and bolt the plate to the flue
3. Fit the probe gasket (C) and insert the probe into the flue.
4. Secure the probe and gasket using nuts and washers (D) as follows:
 - a. 0.5 m (1.7 ft) probe – 6 x M6 nuts and washers
 - b. 1.0 to 4.0 m (3.3 to 13.1 ft) probe – 6 x M10 nuts and washers

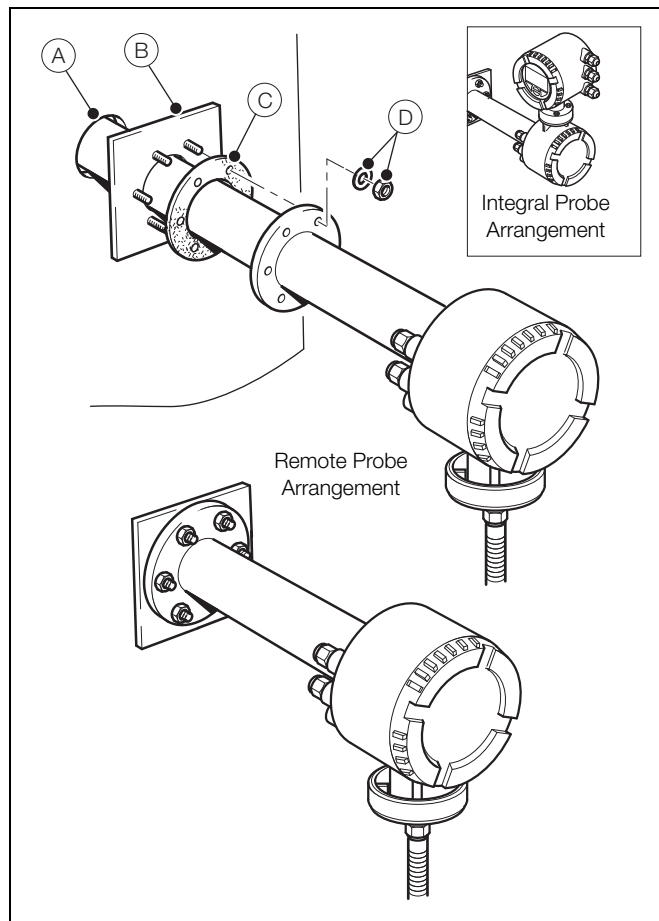

Fig. 3.17 Mounting the Probe

3.9.2 0.5 m (1.64 ft) Probe to Large Probe Adapter Plate Mounting

Note. The following procedure enables a 0.5 m (1.7 ft) probe to be fitted into a large probe (1.0 to 4.0 m [3.3 to 13.1 ft]) ABB Standard flange hole.

1. Locate the adapter gasket (A) on the existing mounting plate.
2. Locate the adapter plate (B) on the gasket.
3. Secure the gasket and plate with 6 x M10 nuts and washers (C).
4. Fit the probe gasket (D) over the probe end. Insert the probe into the flue.
5. Secure the probe and gasket using 6 x M6 screws and washers (E).

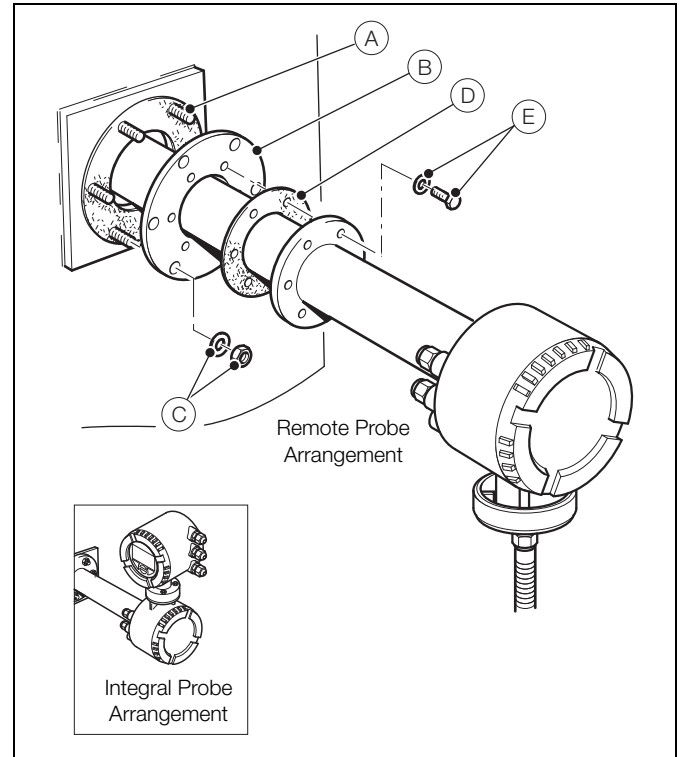

Fig. 3.18 Adaptor Plate Mounting –
0.5 m (1.7 ft) Probe to Large Probe

3.10 End of Life Disposal

Both the integral and remote transmitters contain a small lithium battery that must be disposed of responsibly in accordance with local environmental regulations.

The remainder of the equipment does not contain any substance that causes undue harm to the environment and must be disposed of in accordance with the Directive on Waste Electrical and Electronic Equipment (WEEE). It must not be disposed of in Municipal Waste Collection.

3.11 Endura AZ20 Probe and Transmitter Weights (Unpacked and Packed)

Length m (ft.)	Unpacked – kg (lb)	Packed – kg (lb)
0.5 (1.7)	9 (19.9)	14.2 (31.4)
1.0 (3.3)	11.3 (24.9)	17.9 (39.6)
1.5 (5.0)	13.5 (29.8)	21.7 (47.7)
2.0 (6.6)	15.8 (34.8)	25.4 (55.9)
2.5 (8.2)	18 (39.7)	30.7 (67.7)
3.0 (9.9)	20.3 (44.7)	34.4 (75.8)
3.5 (11.5)	22.5 (49.6)	38.1 (84.0)
4.0 (13.1)	24.8 (54.6)	41.8 (92.2)

Table 3.4 Endura AZ20 Probe Only (Excludes Transmitter)

Length m (ft.)	Unpacked – kg (lb)	Packed – kg (lb)
0.5 (1.7)	12.5 (27.5)	17.72 (39.1)
1.0 (3.3)	14.8 (32.5)	21.43 (47.3)
1.5 (5.0)	17.0 (37.5)	25.14 (55.5)
2.0 (6.6)	19.3 (42.5)	28.35 (63.6)
2.5 (8.2)	21.5 (47.5)	34.17 (75.4)
3.0 (9.9)	23.8 (52.4)	37.38 (83.5)
3.5 (11.5)	26.0 (57.4)	41.59 (91.7)
4.0 (13.1)	28.3 (62.3)	45.30 (99.9)

Table 3.5 Integral Endura AZ20 Probe

Length m (ft.)	Unpacked – kg (lb)	Packed – kg (lb)
0.5 (1.7)	11.5 (25.4)	16.7 (36.9)
1.0 (3.3)	13.6 (30.3)	20.5 (45.1)
1.5 (5.0)	16.0 (35.3)	24.2 (53.3)
2.0 (6.6)	18.3 (40.3)	27.9 (61.4)
2.5 (8.2)	20.5 (42.2)	33.2 (73.2)
3.0 (9.9)	22.8 (50.2)	36.9 (81.3)
3.5 (11.5)	25.0 (55.2)	40.6 (89.5)
4.0 (13.1)	27.3 (60.1)	44.3 (97.7)

Table 3.6 Endura AZ20 Probe and Remote Transmitter

4 Connections

4.1 Electrical Safety

Warning.

- The transmitter is not fitted with a switch therefore a disconnecting device such as a switch or circuit breaker conforming to local safety standards must be fitted to the final installation. It must be fitted in close proximity to the instrument within easy reach of the operator and must be marked clearly as the disconnection device for the transmitter – see IM/AZ20E-EN.
- The probe **must** be bonded to local earth via the external earth connection – see Fig. 4.1.
- Electrical installation and earthing (grounding) must be in accordance with relevant national and local standards.
- Remove all power from supply, relay and any powered control circuits and high common mode voltages before accessing or making any connections.
- The Endura AZ20 cable carries the screened signal wires and the separately screened 90 to 264 V AC heater wires safely. Do not use alternative wires.
- The equipment conforms to Installation Category II of IEC 61010.
- All connections to secondary circuits must have basic insulation.
- After installation, there must be no access to live parts, for example, terminals.
- Terminals for external circuits are for use only with equipment with no accessible live parts.
- If the equipment is used in a manner not specified by the Company, the protection provided by the equipment may be impaired.
- All equipment connected to the transmitter's terminals must comply with local safety standards (IEC 60950, EN61010-1).

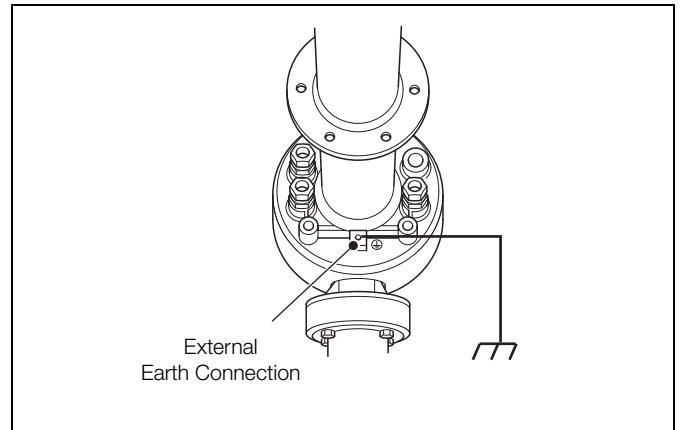

Fig. 4.1 External Earth Connection

Caution.

- Make connections only as shown.
- Maintain Environmental Protection at all times.
- Ensure the seal and mating surfaces are clean to maintain environmental rating.
- Ensure cable glands are tightened after wiring. Do not overtighten the plastic cable glands to avoid destroying their sealing properties. Initially, tighten finger-tight, then a further $1/2$ to $3/4$ turn using a suitable spanner or wrench.
- Fit blanking plugs where required.
- Inductive loads must be suppressed or clamped to limit voltage swings.
- Operation of outputs is programmable.

4.2 Cable Preparation

4.2.1 Endura AZ20 Probe to Remote Endura AZ20 Transmitter

Warning. The Endura AZ20 cable carries the screened signal wires and the separately screened 90 to 264 V AC heater wires safely.

- If alternative cables are used, the cable sizes and insulation specifications must be adhered to and the 90 to 264 V AC heater wires must be screened separately to prevent interference to the signal cables.
- If the signal cables are not contained in a suitable metallic conduit, they must also be screened separately to prevent external interference.

Referring to Fig. 4.2:

1. Expose the signal and screen wires by cutting the outer insulation sheath and screen foil and inner (heater) insulation sheath and screen foil back to the following lengths:
 - Probe connection wires:
 - braided copper shield (A) – 25 to 30 mm (1 to 1.2 in.)
 - connection wires (B) – 100 mm (4 in.)
 - Transmitter connection wires (incl. screens) (C) – 100 mm (4 in.)
2. At both ends of the cable, twist the 2 screen wires (D) together to form one twisted pair at each end and fit an earth sleeve (not supplied) over each twisted pair.

Leave 10 mm (0.4 in.) of each twisted pair exposed for connection at the terminal plugs.
3. Prepare the signal and heater wire ends (E) for connection at the terminal plug(s) by cutting sleeves back to expose 10 mm (0.4 in.) of bare wire.
4. **Important** – on non-AutoCal probes, do not cut the AutoCal wires back to the outer insulation sheath. Instead, bundle them together at both the transmitter and probe end to allow a future AutoCal upgrade if required to be performed using the existing cable.

AutoCal wires comprise:

- White / Yellow – PS2
- White / Black – PS Common
- White / Orange – PS1
- White / Green – SV1
- White / Red – SV Common
- White / Blue – SV2

5. Proceed to Section 4.3, page 20 to make probe cable connections at the remote probe.

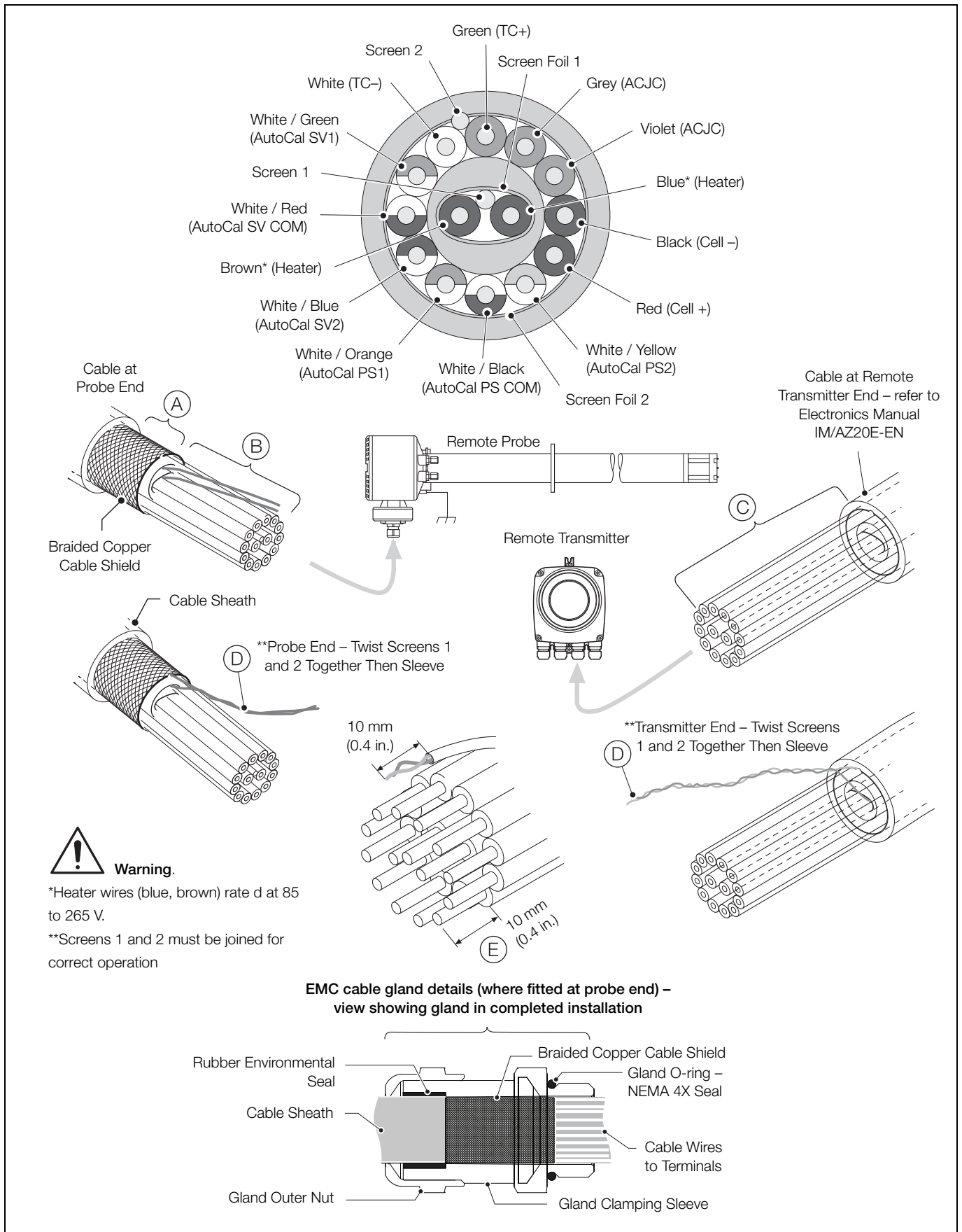

Fig. 4.2 Preparing the Probe Cable

4.3 Electrical Connections

4.3.1 Endura AZ20 Probe Transmitter Connections

Notes.

- Non-AutoCal probes are not fitted with the 6-way AutoCal terminal block or pressure switch / solenoid valve block.
- For probes fitted with AutoCal, make standard connections (steps 1 to 5), then AutoCal connections as detailed in Section 4.3.2, page 21.
- For non-AutoCal probes, retain the unused AutoCal wires to allow for a future upgrade – see Table 4.2 for AutoCal wire colors.

Referring to Fig. 4.3:

1. Unscrew and remove the probe end cap (A).
2. Pass probe cable (B) through probe entry gland (C) taking care not to disturb the existing wiring (D).
3. Remove terminal plug (E) from probe terminal block (F).
4. Make terminal plug connections as shown in Table 4.1:

Terminal / Cable Color	Tag ID	Tx Connection
Violet	ACJC	Pt1000 Cold Junction Compensation
Grey	ACJC	Pt1000 Cold Junction Compensation
Red	Cell +	Oxygen Input (+ve)
Black	Cell -	Oxygen Input (-ve)
Green	TC+	Thermocouple (+ve)
White	TC -	Thermocouple (-ve)
Light Yellow (Sleeved Screens)	SCN	Screens 1 and 2 (Screens 1 and 2 must be connected for correct operation)
Brown	H	Oven
Blue	H	Oven

Table 4.1 Probe Transmitter Cable Connections

5. Carefully connect terminal plug (E) into probe terminal block (F) taking care not to disturb the existing wiring (D).
6. For probes fitted with AutoCal, proceed to Section 4.3.2, page 21.
7. For probes without AutoCal, tighten cable gland (C).
8. Refit the probe end cap (A) and tighten hand-tight.
9. Refer to IM/AZ20E-EN for transmitter connections.

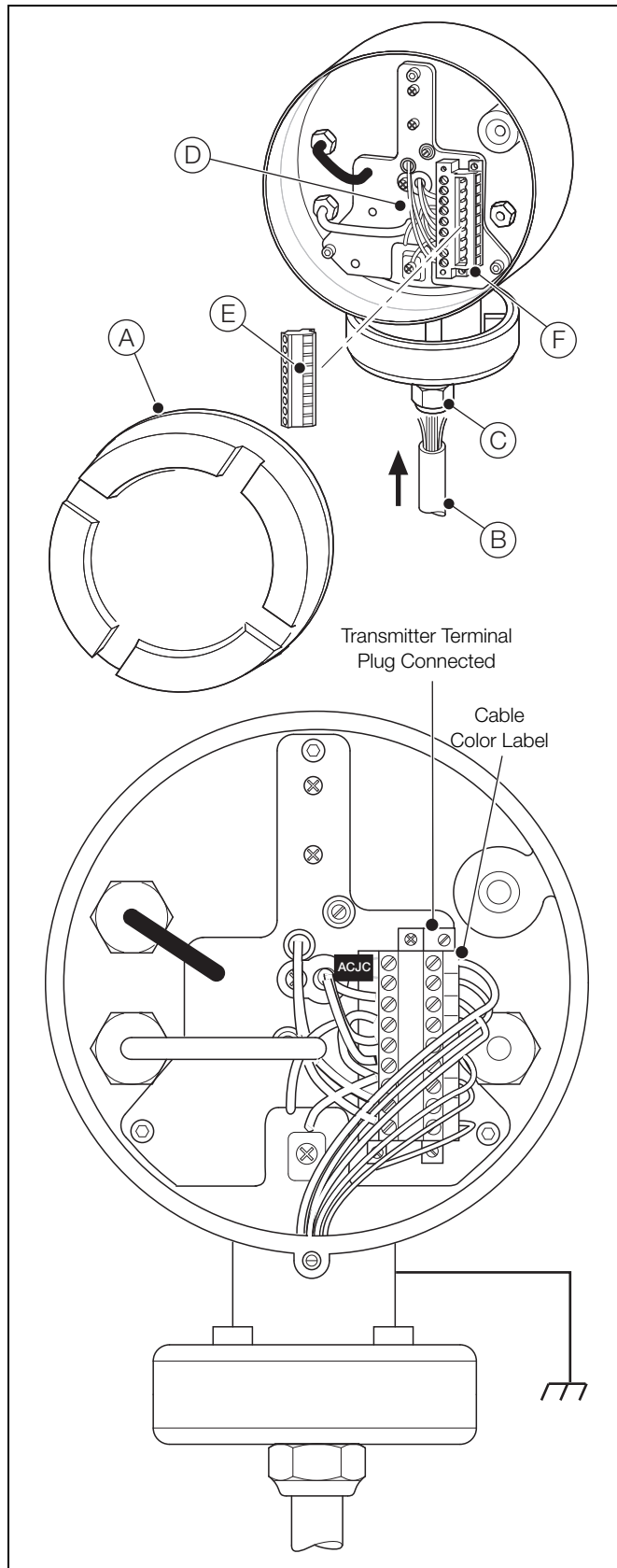

Fig. 4.3 Endura AZ20 Probe Transmitter Cable Connections

4.3.2 AutoCal Connections at Endura AZ20 Probe

1. Make standard connections – see section 4.3.1, page 20, steps 1 to 5.

Referring to Fig. 4.4:

2. Remove terminal plug (A) from probe terminal block (B) taking care not to disturb the existing wiring (C).
3. Make AutoCal terminal plug connections as shown in Table 4.2:

Terminal / Cable Color	Tag ID	AutoCal Connection
White / Yellow	PS2	Pressure Switch Gas 2
White / Black	PS COM	Pressure Switch Common
White / Orange	PS1	Pressure Switch Gas 1
White / Green	SV1	Solenoid Valve Gas 1
White / Red	SV COM	Solenoid Valve Common
White / Blue	SV2	Solenoid Valve Gas 2

Table 4.2 AutoCal Connections at Probe

4. Carefully plug the terminal plug (A) into probe terminal block (B) taking care not to disturb the existing wiring (C).
5. Tighten cable gland (D).
6. Refit the probe end cap (E) and tighten hand-tight.
7. Refer to IM/AZ20E-EN for transmitter connections.

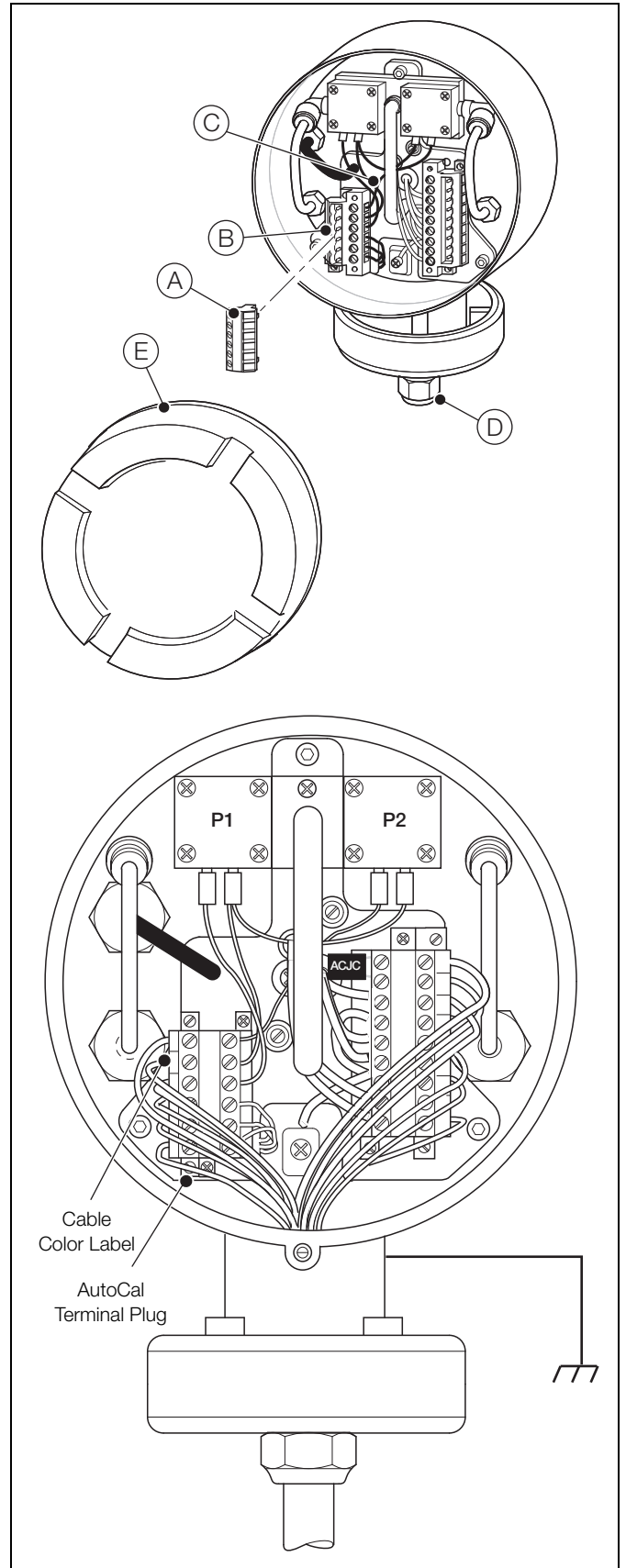

Fig. 4.4 AutoCal Connections at Endura AZ20 Probe

4.4 Gas and Air Connections

Two test gas inlets, one reference air inlet and one vent inlet are located on the probe head. An external earth (bonding) point is also provided.

Caution. Only use clean dry oil-free instrument air,* or traceable certified bottled test gas mixtures of O₂ / N₂.

4.4.1 Restrictors

Systems can be ordered with or without restrictors – refer to Sections 3.5.2 and 3.5.3 on pages 9 and 10 for schematics of all configuration options.

Where restrictors are not fitted, it is necessary to add flowmeters to the test gas lines and reference air line.

- on systems with restrictors, set pressures to 1 bar (15 psi) = 2.2 l / min (0.58 US gal / min)
- on systems without restrictors, pressure is still set to 1 bar (15 psi) then flow is restricted by valves on flowmeters

4.4.2 Connection Types

Note. Connection types comprise:

- 1/4 NPT female threaded entry supplied with 1/4 in OD compression fitting
or
- 1/4 BSP female threaded entry supplied with 6 mm OD compression fitting

4.4.3 Orientation of External Connections

Fig. 4.5 shows the 2 orientations for test gas, reference air and the vent.

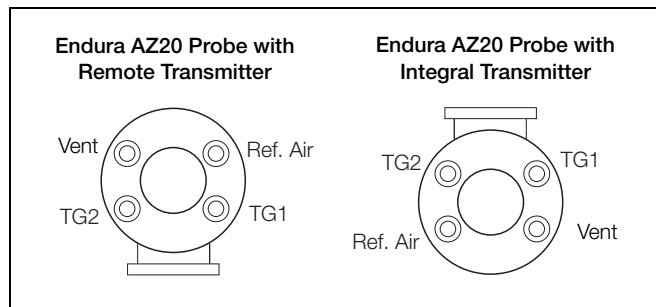

Fig. 4.5 Integral and Remote Endura AZ20 Probe Gas and Air Connections

*ABB recommend our 5 µm / Oil Coalescing Filter Regulator – see Appendix D, page 36.

4.4.4 Test Gas Inlets

Two test (calibration) gas inlets are provided for in situ AutoCal probe testing using a test gas.

If AutoCal is not fitted, Test Gas 1 connection is used for Test Gases 1 and 2. The gas connections are switched manually, as requested by the calibration sequencing in the transmitter.

Note. Test gas connection to non-AutoCal transmitters is made to the external TG1 connection only. TG2 connection is blanked off permanently.

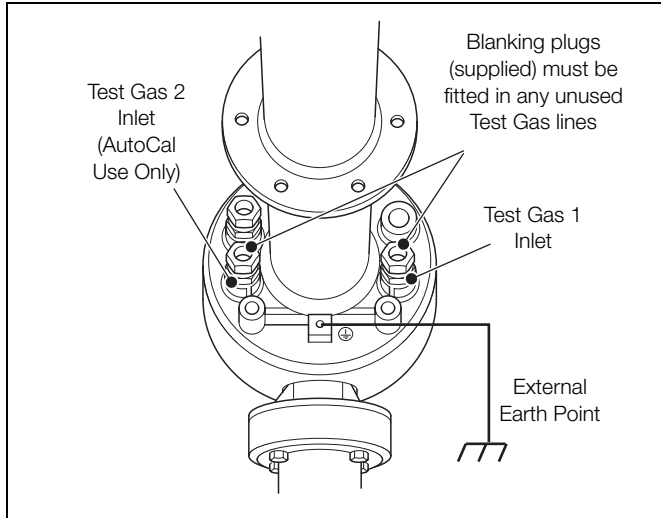

Fig. 4.6 Test Gas Connections –
Endura AZ20 Probe with Remote Transmitter Shown

If the probe is connected permanently to the test gas supply pipework:

- fit a high quality, corrosion-resistant (stainless steel), solenoid valve, manually operated valve or non-return valve (that is leaktight even at zero back-pressure) in the pipework, as close to the test gas inlet valve as possible
- keep the valve closed when the calibration system is not in use

Caution. If the test gas connection is not sealed when not in use, air leaking into the probe via the connection causes measurement errors. In a pressurized flue, gases venting to atmosphere through the connection cause corrosion of, and / or block, the test gas tube. In a negative pressure flue, air leakage causes high O₂ reading errors.

Note. It is preferable to use air (20.95 % O₂) as one of the test gases as this is the sensor's zero point. Alternative representative gases can be used according to local environmental conditions.

To ensure better accuracy, use 2 test gases that represent the top and bottom limits of the known operating range.

Due to resolution accuracies, do not calibrate the system with gases of less than 1 % O₂.

4.4.5 Vent

The vent allows the reference air to escape to atmosphere. If the vent is likely to be exposed to moisture, connect a tube to the vent and route to a dry area.

Ensure that the vent, or the vent tube, does not become blocked during probe use.

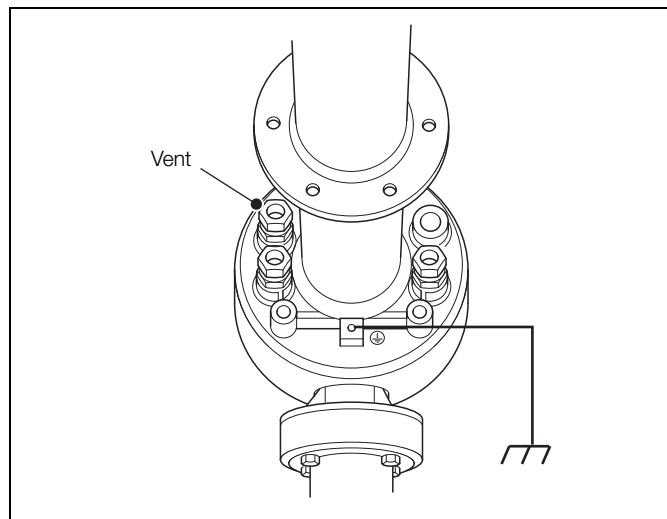

Fig. 4.7 Vent

4.4.6 Reference Air Inlet

A clean, dry, oil-free air supply is required, (for example, from a pump or filter-regulator – see Appendix D, page 36.

Connect the reference air tubing to the external reference air inlet – see Fig. 4.8.

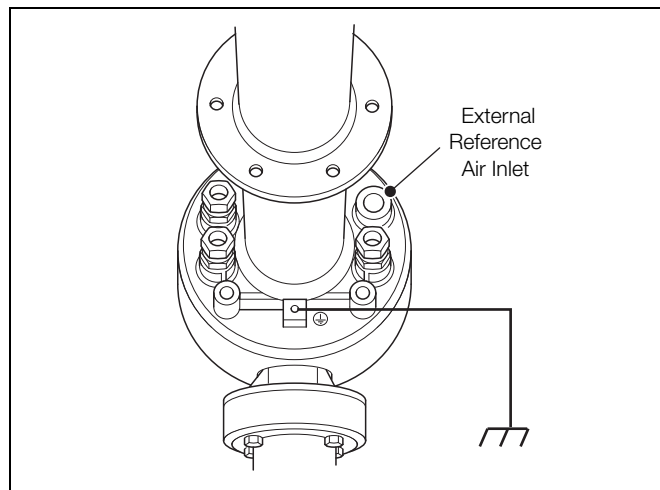

Fig. 4.8 Reference Air Inlet

4.4.7 Inline Shut-off Valves

On non-AutoCal systems, if the test gas line is connected permanently and is >10 m (33 ft.) from the supply, fit non-return valves at the probe head to prevent breathing of flue gas in and out of test gas lines.

Note.

- The reference air supply must be to instrument air standards – clean, dry and free of oil vapor and particle contamination; see schematics in Sections 3.5.2 and 3.5.3 on pages 9 and 10.
- ABB recommend using the ABB 5µm / Oil Coalescing Filter Regulator to supply reference air – see Appendix D, page 36.
- If oil vapor is suspected, use an ABB Reference Air Pump to supply reference air to the probe – see Appendix D, page 30.

4.4.8 Internal Test Gas and Reference Air Tubes

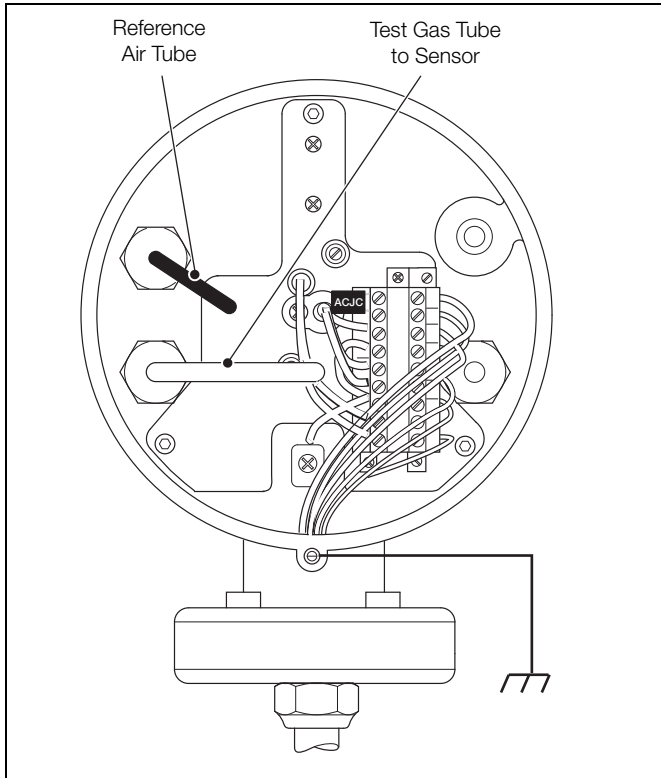

Fig. 4.9 Internal Test Gas and Reference Air Tubes – Non-AutoCal

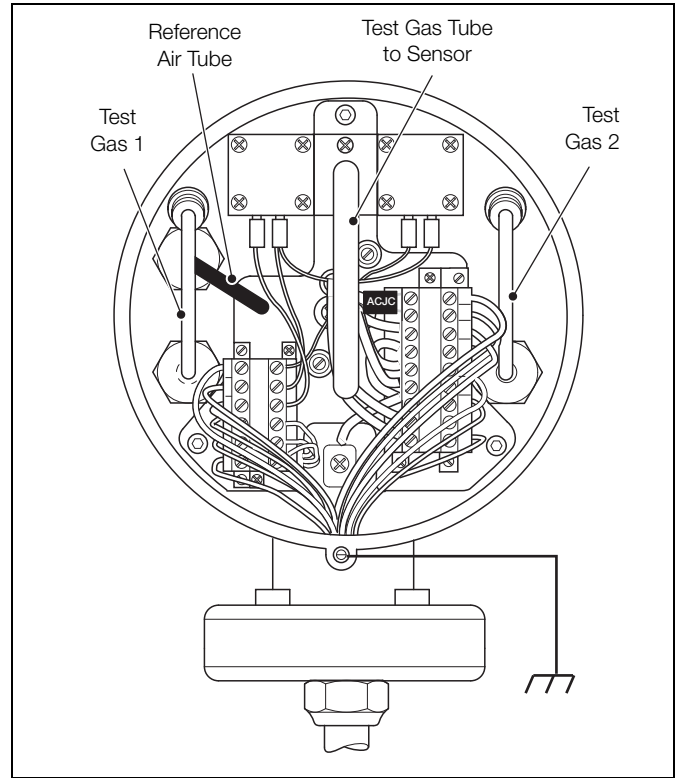

Fig. 4.10 Internal Test Gas and Reference Air Tubes – AutoCal Fitted

5 Start-up and Operation

5.1 Preparation

1. If the probe is not connected permanently to test gas pipework for automatic calibration purposes, ensure blanking plugs are securely fitted to the test gas inlet connections on the probe.
2. If the probe is connected permanently to test gas pipework for automatic calibration purposes, ensure that the valve installed in the pipework adjacent to the test gas connection is closed.

Caution. If the test gas connection is not sealed when not in use, air leaking into the probe via the connection causes measurement errors. In a pressurized flue, gases venting to atmosphere through the connection cause corrosion of, and / or block, the test gas tube. In a negative pressure flue, air leakage causes high O₂ reading errors.

3. Check the connections on both the probe and the transmitter.

Test gas connections must be checked for leaktight joints. Leaks, especially on permanently pressurized AutoCal-fitted probes, can cause errors and drain away expensive bottles of test gas.

4. Adjust the reference air flow to a stable flow rate between 0.3 and 0.5 l / min (0.64 and 1.06 scfh) for probes with no restrictors fitted or 1 bar (15 psi) for probes with restrictors fitted.
 - refer to Section 3.5.2, page 9 for probes fitted with AutoCal.
 - refer to Section 3.5.3, page 10 for probes without AutoCal.

5. Set the test gas flows – Section 5.2, following.
6. Calibrate the system as detailed in IM/AZ20E-EN

Note. Only perform a final system calibration after the probe has been thermally stable for 2 hours.

5.2 Setting Up Test Gases

This section prepares the system for manual and automatic calibration routines by setting up the test gas flows and pressures to suit different AutoCal / restrictor configurations:

- refer to Sections 3.5.2 and 3.5.3, pages 9 and 10 for test gas and reference air supply configurations.
- connections are the same for remote and integral transmitters.

Note. The following sections assume the transmitter and probe are energized, the reference air supply is on and test gases are available.

5.2.1 AutoCal System with Restrictors

To set up an AutoCal system with restrictors:

1. Make test gas and reference air connections as detailed in Section 3.5.2, page 9 (remote or integral transmitter).
2. Turn on Test Gas 1 and set the pressure to a nominal 1 bar (15 psi).
3. At the transmitter, check the *Calibrate / AutoCal Hardware / Hardware Type* parameter is set to *Internal*.
4. At the transmitter, open the *Test Gas 1* valve by selecting: *Calibrate / AutoCal Hardware / Valve Manual Control / Test Gas 1* and pressing  to open the valve.

A small icon is displayed to indicate the valve is in the *Open* position:

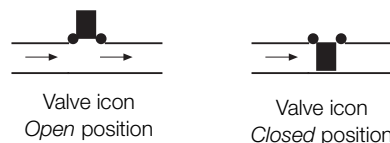

5. Fine tune Test Gas 1 pressure to 1 bar (15 psi).
6. Turn gas off at the transmitter by pressing , then turn Test Gas 1 off at the supply.
7. Repeat steps 2 to 6 for Test Gas 2 (if present).
8. Refer to IM/AZ20E-EN to perform a calibration when required.

5.2.2 AutoCal System without Restrictors

To set up an AutoCal system without restrictors:

1. Make test gas and reference air connections as detailed in Section 3.5.2, page 9 (remote or integral transmitter).
2. Turn on Test Gas 1 and set the pressure to a nominal 1 bar (15 psi).
3. At the transmitter, check the *Calibrate / AutoCal Hardware / Hardware Type* parameter is *Internal*.
4. At the transmitter, open the 'Test Gas 1' valve by selecting: *Calibrate / AutoCal Hardware / Valve Manual Control / Test Gas 1* and pressing  to open the valve.

A small icon is displayed to indicate the valve is in the Open position:

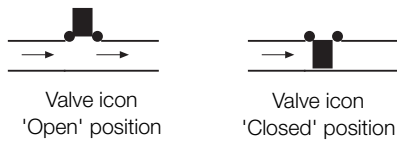

5. Fine tune Test Gas 1 pressure to 1 bar (15 psi) and set the flow on the flowmeter to 2.2 l / min (4.662 scfh).
6. Turn gas off at the transmitter by pressing , then turn Test Gas 1 off at the supply.
7. Repeat steps 2 to 6 for Test Gas 2 (if present).
8. Refer to IM/AZ20E-EN to perform a calibration when required.

5.2.3 Non-AutoCal System with Restrictors

To set up an Non-AutoCal system with restrictors:

1. Make test gas and reference air connections as detailed in Section 3.5.3, page 10 (remote or integral transmitter).

Note. Test Gas 1 and 2 connections are made to the probe's external Test Gas 1 (TG1) connection and must be switched manually – see section 3.5.3, page 10.

2. Turn on Test Gas 1 and adjust the pressure to 1 bar (15 psi).
3. Turn Test Gas 1 off at the supply.
4. Repeat steps 2 to 4 for Test Gas 2 (if present), connect the Test Gas 2 line to the probe's external TG1 connection.
5. Refer to IM/AZ20E-EN to perform a calibration when required.

5.2.4 Non-AutoCal System without Restrictors

To set up an Non-AutoCal system without restrictors:

1. Make test gas and reference air connections as detailed in Section 3.5.3, page 10 (remote or integral transmitter).

Note. Test Gas 1 and 2 connections are made to the probe's external Test Gas 1 (TG1) connection and must be switched manually – see section 3.5.3, page 10.

2. Turn on Test Gas 1, adjust the pressure to 1 bar (15 psi) and the flow on the flowmeter to 2.2 l / min (4.662 scfh).
3. Turn Test Gas 1 off at the supply.
4. Repeat steps 2 to 4 for Test Gas 2 (if present), connecting the Test Gas 2 line to the probe's external TG1 connection.
5. Refer to IM/AZ20E-EN to perform a calibration when required.

6 Endura AZ20 Probe Specification

Physical

Probe insertion lengths

0.5 m (1.7 ft.)	2.5 m (8.2 ft.)
1.0 m (3.3 ft.)	3.0 m (9.9 ft.)
1.5 m (5.0 ft.)	3.5 m (11.5 ft.)
2.0 m (6.6 ft.)	4.0 m (13.1 ft.)

Process connection

All probe lengths:
ANSI B16.5 150 lb
2, 2.5, 3, 4 in
DIN2501 Part 1
65, 80, 100 mm
JIS B2238 5K
NPT

(flange pressure ratings do not apply)

0.5 m (1.7 ft.) probes	ABB 500 mm (19.7 in) standard flange
1.0 m (3.3 ft.) and longer	ABB 1000 mm (39.4 in) standard flange

Probe body material

316L stainless steel

Mounting angle

Horizontal to vertically down

Note. Horizontally-mounted probes greater than 2.0 m (6.6 ft.) in length may need to be supported.

Process Conditions

Standard process temperature

All probe lengths* -20 to 800 °C (-4 to 1472 °F)

Process pressure

Designed to withstand 35 kPa (5.1 psi) – positive or negative
(pressure compensation required above 5 kPa (0.7 psi) – transmitter
can apply fixed pressure compensation

* For > 2 m (6.6 ft.) probes, special conditions may apply

Operating requirements

Reference air

Regulated supply	Probes with restrictors	1 bar (15 psi), flowmeters not required
	Probes without restrictors	1 bar (15 psi) flowmeters required with flow set to 0.3 to 0.5 l / min (0.64 to 1.06 scfh)
Pumped supply	Probes with / without restrictors	Preset flow 0.3 to 0.5 l / min (0.64 to 1.06 scfh)

Test gas

User-selectable, 100 to 0.1 % O₂ balance N₂ and / or air
(air is recommended as one of the test gases)

Probes with restrictors	1 bar (15 psi) – flowmeters not required as restrictors preset flow to 2.2 l / min (4.662 scfh)
Probes without restrictors	1 bar (15 psi) flowmeters required, set to 2.2 l / min (4.662 scfh) flow

Calibration

Manual, semi-automatic or automatic
(controlled by Endura AZ20 transmitter)

Automatic calibration

AutoCal hardware

Optional built-in solenoid valves for control of test gas flow
Built-in pressure switches to detect presence of test gases

Heater Operational Requirements

AZ20 Probe

Nominally 190 Ω, 70 W at 115 V AC – power is limited to 70 W max.
by AZ20 transmitter over an 85 to 265 V AC range.

AZ20 / ZFG2 Replacement Probe

Nominally 25Ω, 120 W at 55 V AC – for use only with a ZDT analyzer
or ZMT transmitter

DS/AZ20-EN Rev. J

Appendix A – Principle of Operation

The Endura AZ20 probe's zirconia cell is a thimble-shaped sensing element fitted with inner and outer electrodes at its closed end. The inner electrode is exposed to the flue gas entering the open end of the cell; the outer electrode is supplied with reference air from a pump or regulator and is therefore exposed to a constant partial pressure of oxygen (20.95 % O₂). The cell is held at a constant 700°C (1292 °F) by a heater and control thermocouple.

Because zirconia is an electrolyte that conducts only oxygen ions at temperatures in excess of 600°C (1112 °F), the voltage generated between the electrodes (the cell output) is a function of the ratio of the oxygen partial pressure difference between the reference electrode and the measuring electrode and its temperature. Therefore, any change in the oxygen partial pressure of the flue gas at the exposed electrode produces a change in the cell output voltage as dictated by the Nernst equation.

Cell output voltage increases logarithmically with decreasing oxygen, thus providing high sensitivity at low oxygen levels.

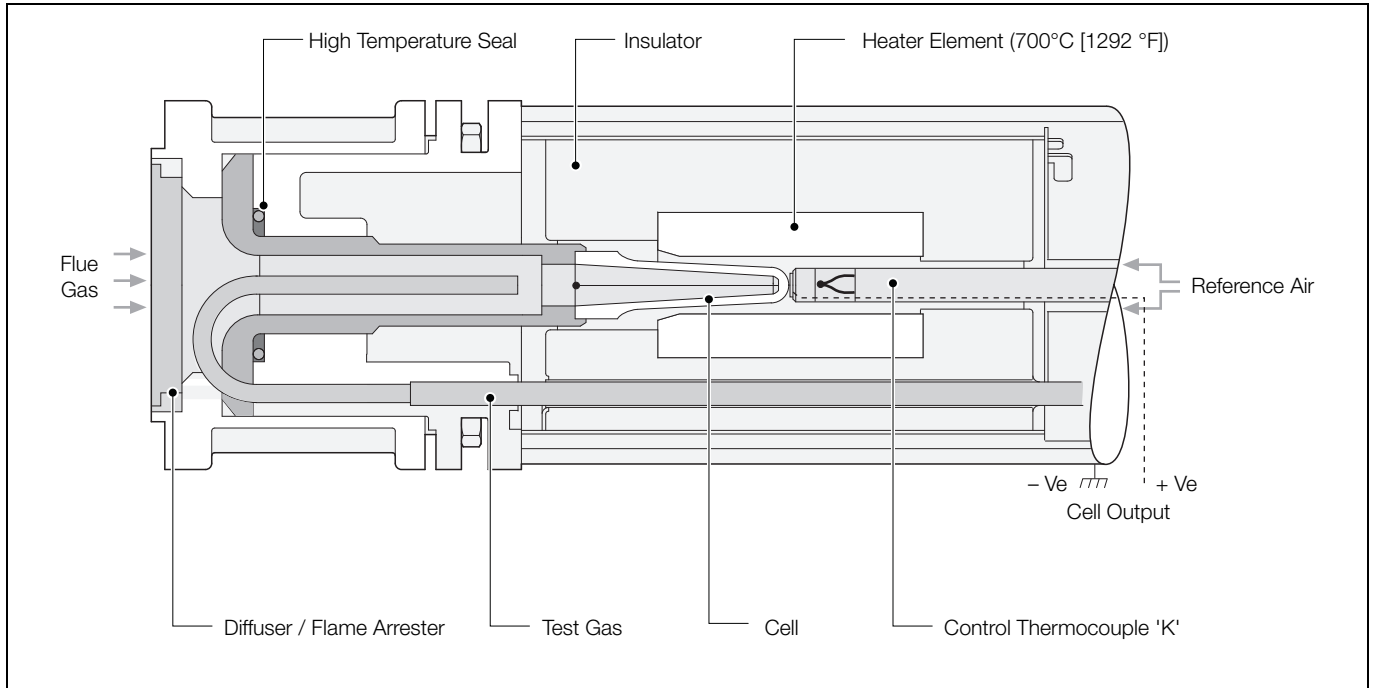

Fig. A.1 Endura AZ20 Probe Construction

Appendix B – Endura AZ20/ZFG2 Replacement Probe

The Endura AZ20/ZFG2 replacement probe can be connected to existing ZMT transmitters or ZDT-FG analyzers to replace existing ZFG2 probes. To allow direct replacement, Endura AZ20/ZFG2 replacement probes are supplied with a single M20 gland conduit of 6 or 10 m (18 or 30 ft) length. NPT versions are supplied with a single 1/2 in NPT female threaded entry only.

Note. For Endura AZ20/ZFG2 replacement probe test gas and connection details at the existing ZMT transmitter or ZDT-FG analyzer, refer to the following manuals:

- IM/ZDT-FG – copies of the IM/ZDT/FG manual can be downloaded from the ABB web site (www.abb.com).
- IM/ZMT – copies of the IM/ZMT manual can be downloaded from the ABB website (www.abb.com).

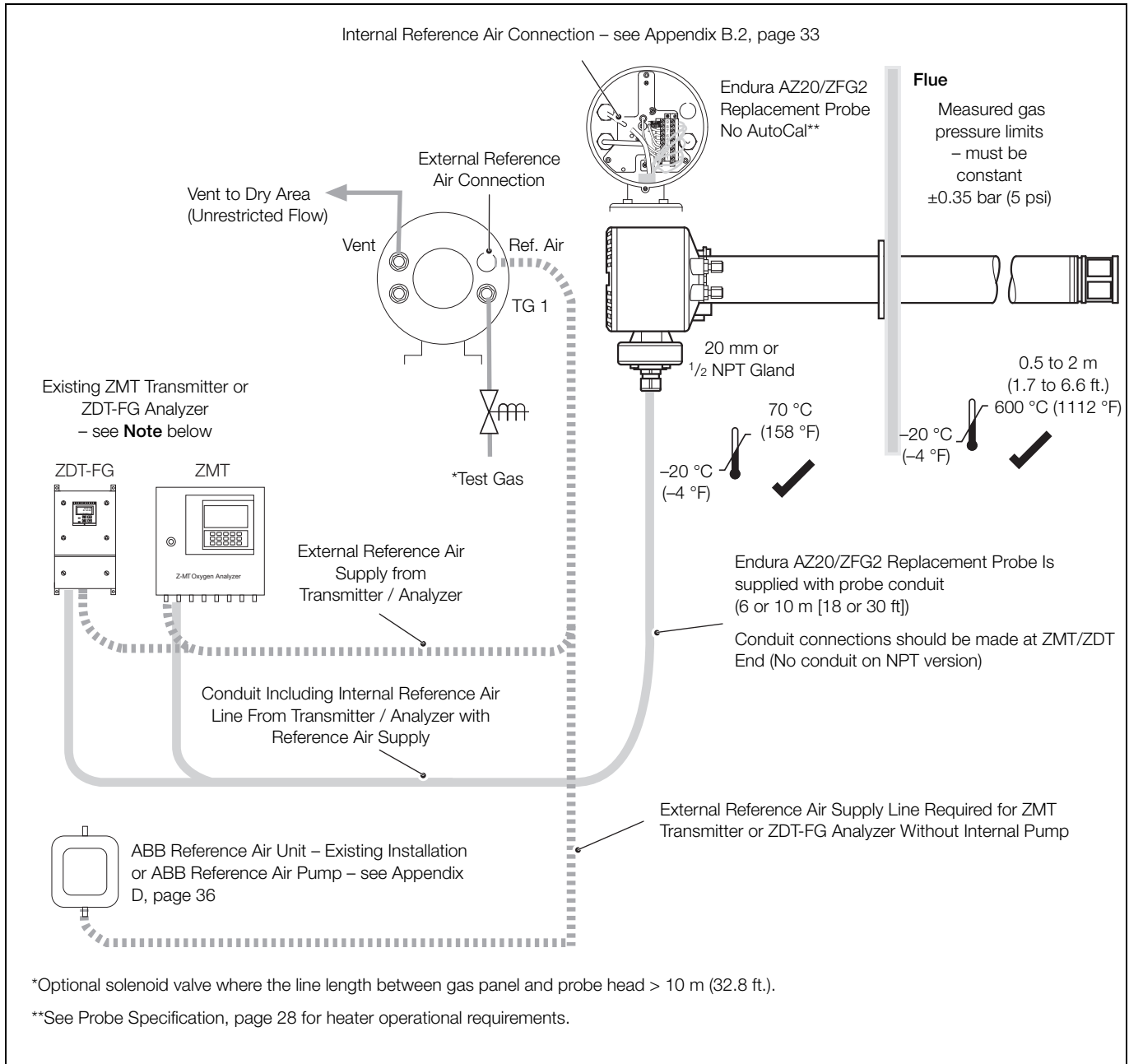

Fig. B.1 Endura AZ20/ZFG2 Replacement Probe with Existing System

B.1 Endura AZ20/ZFG2 Replacement Probe Conduit Electrical Connections

Important.

- For removal of the existing ZFG2 probe (complete with its conduit assembly) and installation of the Endura AZ20/ZFG2 replacement probe, refer to the ZFG2 probe manual (this manual can be downloaded from the ABB web site at (www.abb.com) or by clicking the following link: [IM/ZFG2](#)).
- The Endura AZ20/ZFG2 replacement probe must be installed using the new conduit supplied with the probe.

B.1.1 Electrical Connections

Referring to Fig. B.2:

1. Unscrew and remove probe end cap (A).
2. Pass conduit (B) through probe entry gland (C) taking care not to disturb the probe's internal wiring (D).
3. Tighten cable gland (C).
4. Make connections (E) to colored terminal plug connections as shown in Table B.1:

Terminal / Cable Color	Tag ID	Connection
Violet	Not Used	
Grey		
Red	Cell +	Oxygen Input (+ve)
Blue	Cell -	Oxygen Input (-ve)
White	TC+	Thermocouple (+ve)
Blue	TC -	Thermocouple (-ve)
Braid	Cell SCN	Screen
Brown	H	Heater
Blue	H	Heater

Table B.1 Probe Transmitter Cable Connections

5. Make reference air connections as detailed in Appendix B.1.2, page 32.

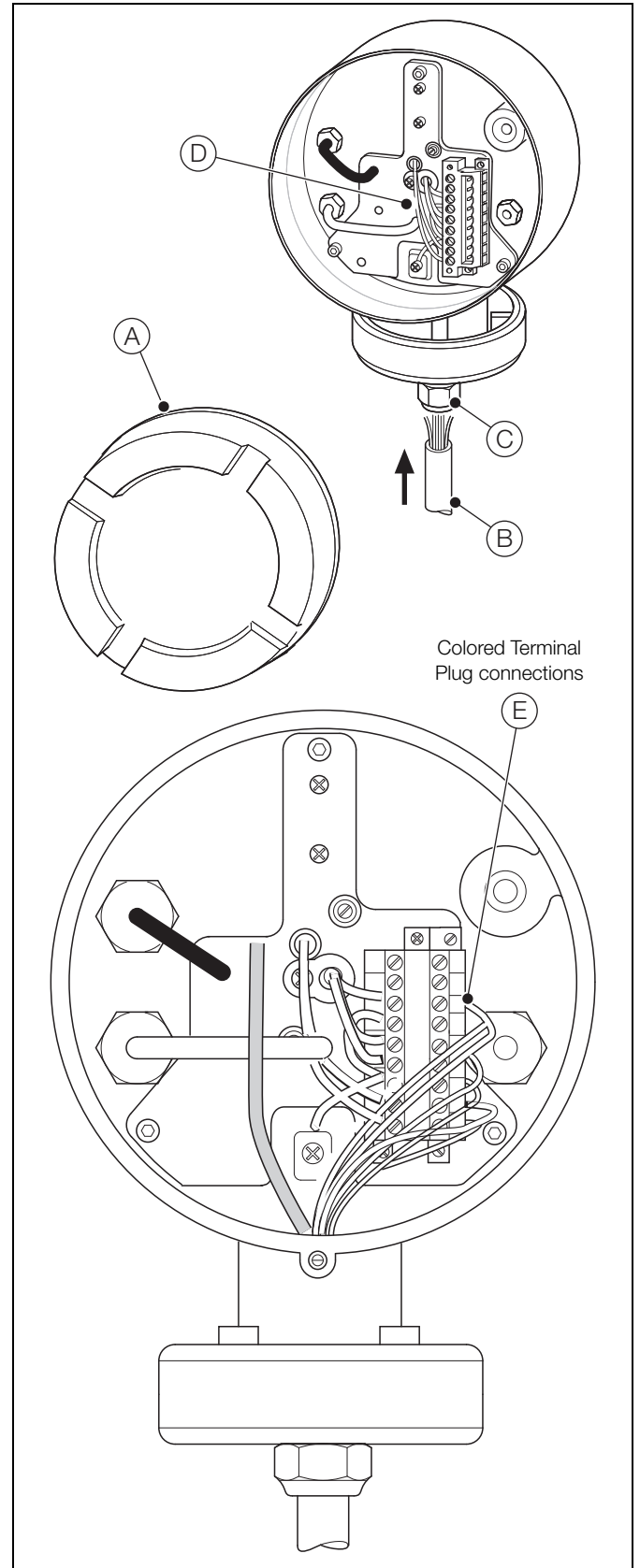

Fig. B.2 Endura AZ20/ZFG2 Replacement Probe – Conduit Electrical Connections

B.1.2 Endura AZ20/ZFG2 Replacement Probe – Conduit Reference Air Connections

Referring to Fig. B.3:

1. For probes using the conduit (internal) Reference Air line:
 - a. disconnect pipe (A) at the hexagonal fitting (B).
 - b. reconnect pipe (A) to the internal Reference Air tube (C) coming from the conduit – ensure flexible tubing does not kink (especially after the probe end cap is re-fitted)
 - c. fit a blanking plug to the external 'Ref. Air' connection at (B) on the probe body to prevent water ingress
 - d. proceed to step 3.
2. For probes using an external Reference Air line, connect the existing reference air supply line to the probe's external 'Ref. Air' connection – see section 4.4.6, page 24.
3. Refit probe end cap (D) and screw it hand-tight.
4. Refer to Appendix B.2, page 33 for connections to ZDT-FG analyzers or Appendix B.3 page 34 for connections to ZMT transmitters.

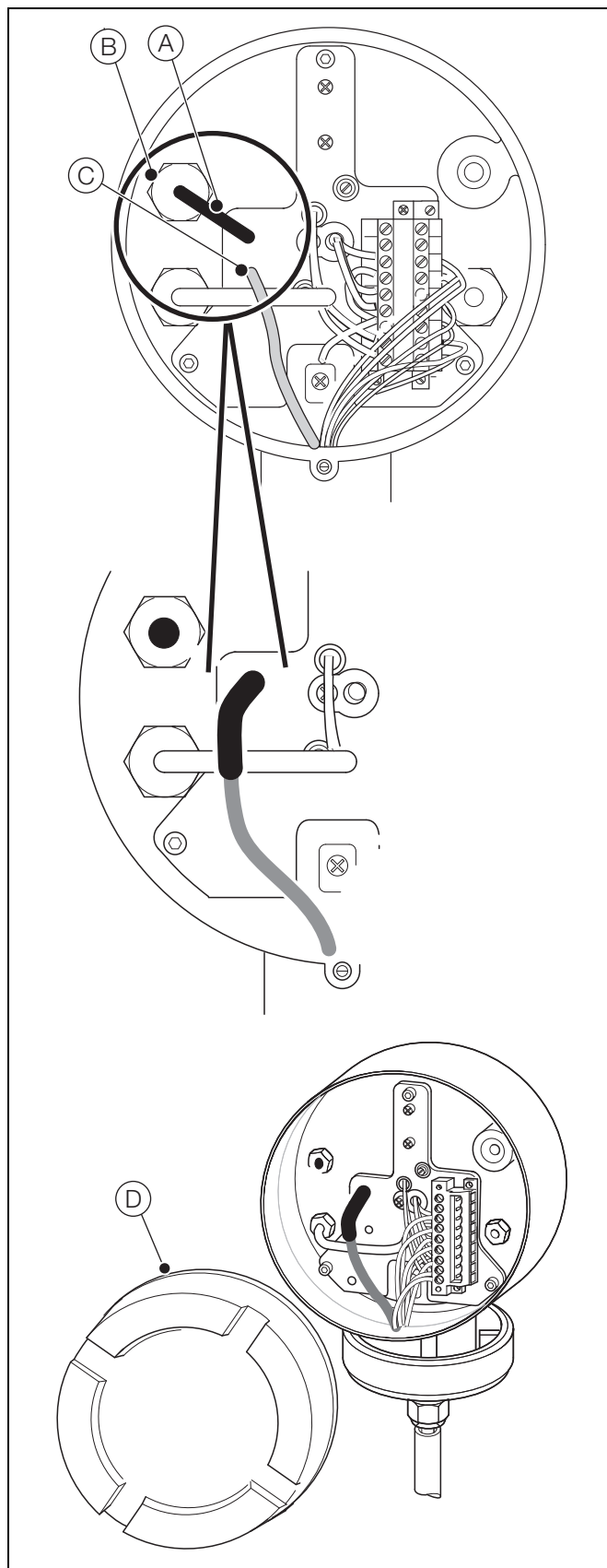

Fig. B.3 Endura AZ20/ZFG2 Replacement Probe –
Conduit Reference Air Connections

B.2 ZDT-FG Analyzer Connections

Warning. Before disconnecting existing ZFG2 conduit, or connecting the new Endura AZ20/ZFG2 replacement probe conduit, ensure the power supply, any powered control circuits and high common-mode voltages are switched off.

B.2.1 Disconnecting the Existing ZFG2 Probe

Referring to Fig. B.4:

1. Unlock and remove the lower panel (A) from the ZDT-FG analyzer, remove the 2 shroud retaining screws (B) and remove shroud (C).
2. Disconnect wires from heater terminal (D), cell terminal (E), thermocouple terminal (F) and loosen conduit entry gland (G).
3. For analyzers using the conduit's Reference Air line, disconnect existing reference air supply (H), remove the conduit and proceed to step 5.
4. For analyzers using an external Reference Air connection, leave the existing reference air supply pipe (I) in place.

Note. For analyzers without internal pumps, the Reference Air connection is made directly to the probe's external 'Ref. Air' connection – see Fig. B.1, page 30.

B.2.2 Connecting the Endura AZ20/ZFG2 Replacement Probe

Referring to Fig. B.4:

1. Pass the new conduit through entry gland (G) and tighten the gland.
2. Make connections to heater terminal (D), cell terminal (E), thermocouple terminal (F) as shown in Table B.2.

ZDT-FG Terminal	Connection	Wire
H	Heater	Brown
H	Heater	Blue
E	Heater Earth	Green / Yellow
Cell +	Oxygen Input (+ve)	Red
Cell -	Oxygen Input (-ve)	Blue
Cell SCN	Oxygen Input Screen	Braid
TC+	Thermocouple (+ve)	White
TC-	Thermocouple (-ve)	Blue

Table B.2 Conduit Connections at ZDT-FG Analyzer

3. For probes using the conduit's Reference Air supply, connect conduit reference air line (H).
4. Refit shroud (C) and secure it with the 2 shroud retaining screws (B).
5. Refit the lower panel (A).

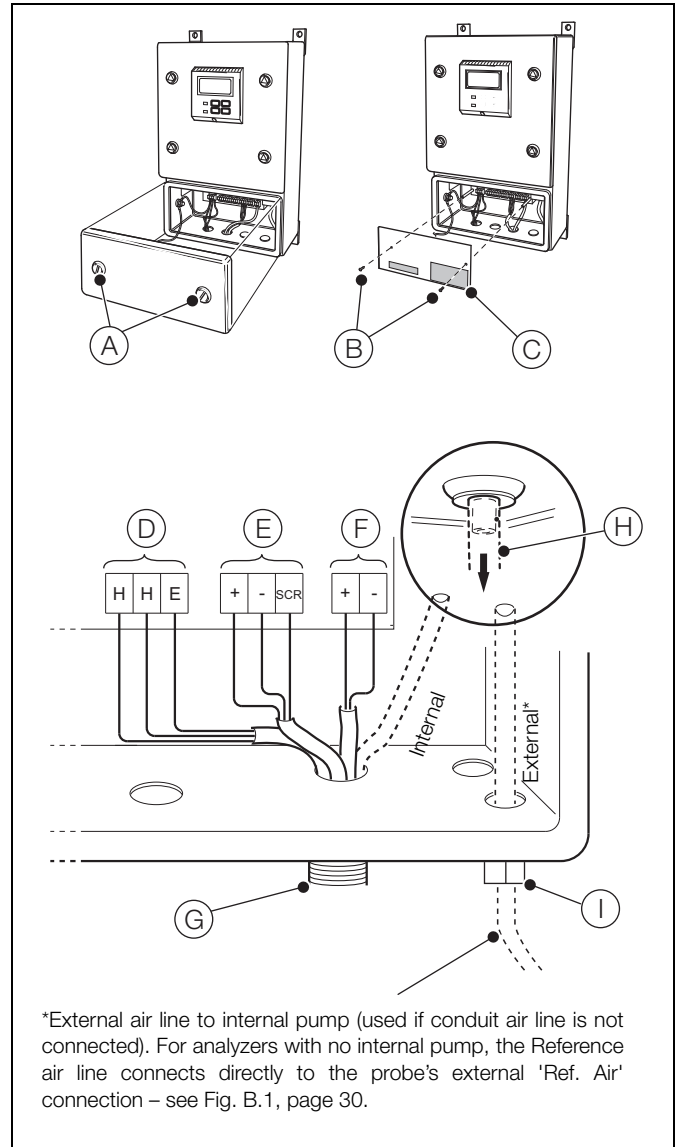

Fig. B.4 Endura AZ20/ZFG2 Replacement Probe Conduit Connections at ZDT-FG Analyzer

B.3 ZMT Transmitter Connections

Warning. Before disconnecting or connecting conduit, ensure the power supply, any powered control circuits and high common-mode voltages are switched off.

B.3.1 Disconnecting the Existing ZFG2 Probe

Referring to Fig. B.3:

1. Unlock and open the door (A), remove the 2 retaining screws (B) and remove the mains protection plate (C).
2. Disconnect wires from heater terminal (D), cell terminal (E) and thermocouple terminal (F) and loosen conduit entry gland (G).
3. For probes using the conduit's Reference Air line, disconnect existing reference air supply pipe (H), remove the conduit and proceed to step 5.
4. For probes using an external Reference Air connection, leave the existing reference air supply (I) in place.

Note. For transmitters without internal pumps, the Reference Air connection is made directly to the probe's external 'Ref. Air' connection – see Fig. B.1, page 30.

B.3.2 Connecting the Endura AZ20/ZFG2 Replacement Probe

Referring to Fig. B.3:

1. Pass the new conduit through entry gland (G) and tighten the gland.
2. Make connections to heater terminal (D), cell terminal (E) and thermocouple terminal (F), as listed in Table B.2.

ZMT Terminal	Connection	Wire
H	Heater	Brown
H	Heater	Blue
E	Heater Earth	Green / Yellow
Cell +	Oxygen Input (+ve)	Red
Cell -	Oxygen Input (-ve)	Blue
Cell SCN	Oxygen Input Screen	Braid
TC+	Thermocouple (+ve)	White
TC-	Thermocouple (-ve)	Blue

Table B.3 Conduit Connections at ZMT Transmitter

3. For probes using the conduit's Reference Air supply, connect conduit reference air line (H).
4. Refit the mains protection plate (C) and secure it with the 2 retaining screws (B).
5. Close and lock the door (A).

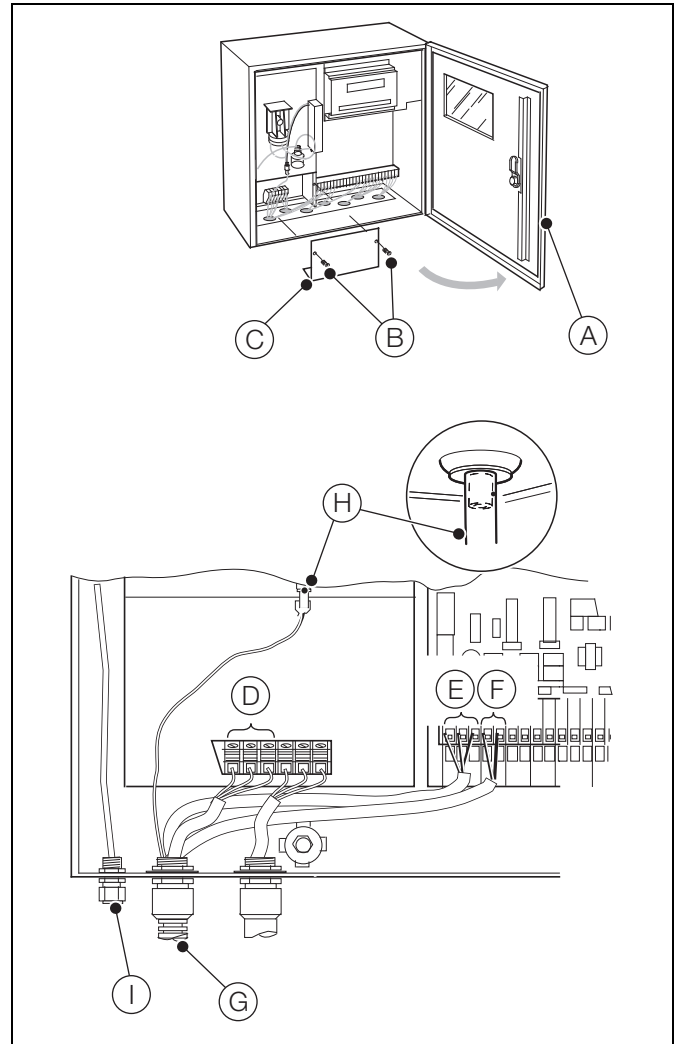

Fig. B.5 Endura AZ20/ZFG2 Replacement Probe Conduit Connections at ZMT Transmitter

Appendix C – Using an External Automatic Calibration Panel

Warning. Isolate the Endura AZ20 transmitter and external automatic calibration panel before making AutoCal connections.

Referring to Fig. C.1, relay outputs 1 and 2 from the Endura AZ20 transmitter can be used to switch solenoid valves in an external automatic calibration panel to provide AutoCal functionality. The external automatic calibration components must be powered by an independent supply.

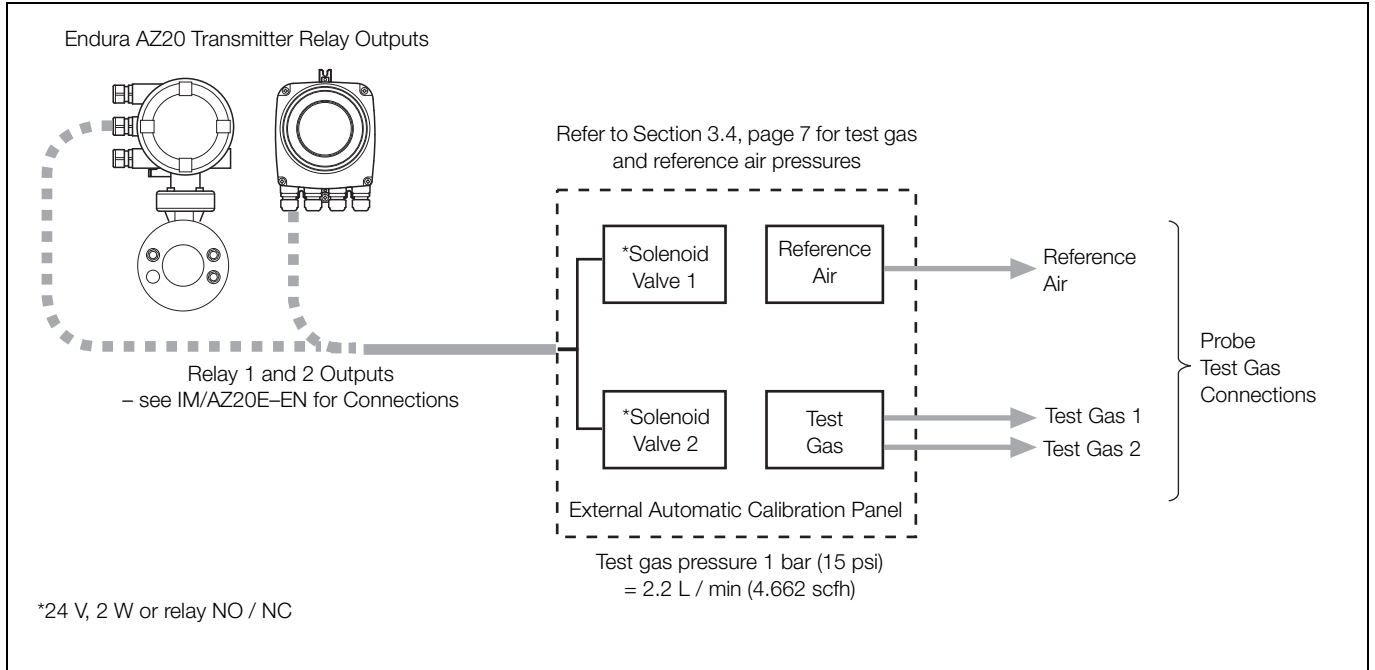



Fig. C.1 Schematic – Example of External Automatic Calibration Panel

Appendix D – Accessories and Spares

D.1 Documentation

Part No.	Description
IM/AZ20M-EN	<p>Maintenance Guide</p> <p>Download* the Maintenance Guide from: www.ABB.com/analytical-instruments</p> <p>*Enter this address in your browser and then type IM/AZ20M-EN in the search box. The Maintenance Guide is the top link.</p> 

D.2 Probe Spares

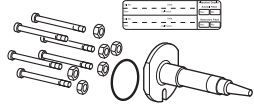
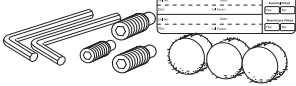
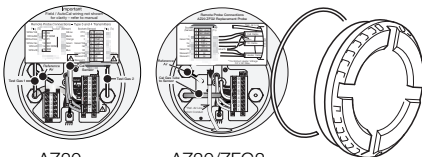
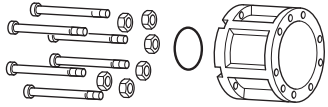
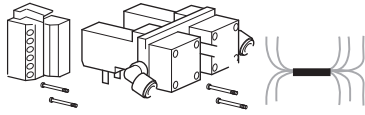
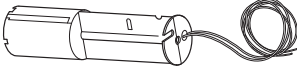
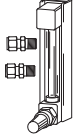
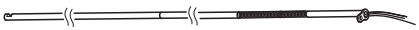
Part No.	Description
AZ200 700	<p>Cell Assembly (includes Commissioning label and C-ring)</p> 
AZ200 727	<p>Restrictor Upgrade Kit</p> 
AZ200 728	<p>Probe End Cap (includes wiring labels)</p>  <p>AZ20 Version AZ20/ZFG2 Replacement Version</p>
AZ200 729	<p>Diffuser Assembly (includes C-ring)</p> 
AZ200 730 (NPT) AZ200 733 (BSP)	<p>AutoCal Upgrade Assembly</p> 
Length dependant: AZ20 Standard – see Table D.2 AZ20/ZFG2 Replacement Probe – see Table D.3	<p>AZ20 Standard Heater Assembly AZ20/ZFG2 Replacement Heater Assembly</p> 
Application dependant – see Table D.4	<p>ABB Flowmeter</p> 
Length dependant – see Table D.1	<p>Thermocouple / Electrode Assembly</p> 

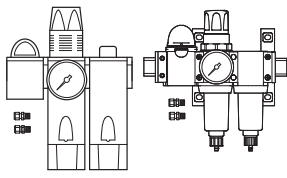
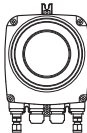
Part No.	Description
AZ200 731 AZ200 732	<p>Oil-coalescing Filter-Regulator: 1/4 NPT 5 µm 1/4 BSP 5 µm</p>  <p>Pre-June 2013 regulator Post-June 2013 regulator</p>
AZ200 740 AZ200 741	<p>Filter elements for pre-June 2013 regulator: 5µm filter element Oil coalescing filter element</p>
AZ200 742 AZ200 743	<p>Filter elements for post-June 2013 regulator: 5µm filter cartridge Oil coalescing filter cartridge</p>
AZ200 770 AZ200 771 AZ200 772 AZ200 773	<p>ABB Reference Air Pump: 1/4 BSP (Metric) 230 V AC 50 / 60 Hz 1/4 BSP (Metric) 115 V AC 50 / 60 Hz 1/4 NPT (Imperial) 230 V AC 50 / 60 Hz 1/4 NPT (Imperial) 115 V AC 50 / 60 Hz</p> 

Probe Length	Part Number	Probe Length	Part Number
0.5 m (1.7 ft.)	AZ200 701	2.5 m (8.2 ft.)	AZ200 705
1.0 m (3.3 ft.)	AZ200 702	3.0 m (9.9 ft.)	AZ200 706
1.5 m (5.0 ft.)	AZ200 703	3.5 m (11.5 ft.)	AZ200 707
2.0 m (6.6 ft.)	AZ200 704	4.0 m (13.1 ft.)	AZ200 708

Table D.1 Thermocouple / Electrode Assembly

Probe Length	Part Number	Probe Length	Part Number
0.5 m (1.7 ft.)	AZ200 710	2.5 m (8.2 ft.)	AZ200 714
1.0 m (3.3 ft.)	AZ200 711	3.0 m (9.9 ft.)	AZ200 715
1.5 m (5.0 ft.)	AZ200 712	3.5 m (11.5 ft.)	AZ200 716
2.0 m (6.6 ft.)	AZ200 713	4.0 m (13.1 ft.)	AZ200 717

Table D.2 AZ20 Standard Probe Heater Assembly

Probe Length	Part Number
0.5 m (1.7 ft.)	AZ200 720
1.0 m (3.3 ft.)	AZ200 721
1.5 m (5.0 ft.)	AZ200 722
2.0 m (6.6 ft.)	AZ200 723

Table D.3 AZ20/ZFG2 Replacement Probe Heater Assembly

Flowmeter Type	Part Number
1/4 NPT Flowmeter (Reference Air): 0.1 to 0.85 l / min (0.21 to 1.8 scfh) STP	AZ200 786
1/4 BSP Flowmeter (Reference Air): 0.1 to 0.85 l / min (0.21 to 1.8 scfh) STP	AZ200 787
1/4 NPT Flowmeter (Test Gas): 0.6 to 4.4 l / min (1.27 to 9.32 scfh) STP	AZ200 788
1/4 BSP Flowmeter (Test Gas): 0.6 to 4.4 l / min (1.27 to 9.32 scfh) STP	AZ200 789

Table D.4 ABB NPT/BSP Flowmeters

Sales



Service



Software



ABB Limited

Measurement & Analytics

Oldends Lane, Stonehouse
Gloucestershire,
GL10 3TA
UK

Tel: +44 (0)1453 826661

Fax: +44 (0)1453 829671

Email: instrumentation@gb.abb.com

ABB Inc.

Measurement & Analytics

125 E County Line Road
Warminster, PA 18974
USA

Tel: +1 215 674 6000

Fax: +1 215 674 7183

abb.com/measurement













We reserve the right to make technical changes or modify the contents of this document without prior notice. With regard to purchase orders, the agreed particulars shall prevail. ABB does not accept any responsibility whatsoever for potential errors or possible lack of information in this document.

We reserve all rights in this document and in the subject matter and illustrations contained therein. Any reproduction, disclosure to third parties or utilization of its contents – in whole or in parts – is forbidden without prior written consent of ABB.

Copyright© ABB 2018
All rights reserved



Our offering:

	Actuators and Positioners		Analytical Instruments
	Device Management, Fieldbus and Wireless		Flow Measurement
	Force Measurement		Level Measurement
	Natural Gas Measurement		Pressure Measurement
	Recorders and Controllers		Temperature Measurement

HMI – Automação e Instrumentação, Lda.

Travessa da Indústria, nº 111
4780-573 Santo Tirso
PORTUGAL

Tel. +351 252 850 501
Fax. +351 300 013 487

Web: www.hmi.pt

Email: hmi@hmi.pt