



hmi

high-accuracy
measurement
instruments

FICHA TÉCNICA DE PRODUTO

PRODUCT DATASHEET

HMI – Automação e Instrumentação, Lda.

Travessa da Indústria, nº 111
4780-573 Santo Tirso
PORTUGAL

Tel. +351 252 850 501
Fax. +351 300 013 487

Web: www.hmi.pt

Email: hmi@hmi.pt

ABB MEASUREMENT & ANALYTICS | DATA SHEET

LP

Linear pneumatic piston actuator



Measurement made easy

Cylinder actuators

- **High resolution, sensitivity and fast response**
- **Cylinders available with Buna-N® or Viton® seals**
- **Suitable for high temperature applications**
- **Easy adaptability to air dampers and louvers**
- **Drop-in replacement for many older piston actuators**
- **Available with 4 to 20 mA position feedback**
- **Digital features with TZIDC positioner**
- **Explosion proof application with TZIDC-200 positioners**
- **Communication with HART®/FOUNDATION Fieldbus®/PROFIBUS PA®**

Cylinder actuators from 63.5 mm (2½ in) dia. × 127 mm (5 in) stroke to 254 mm (10 in) dia. × 406.4 mm (16 in) stroke

Linear pneumatic (LP) piston actuators are typically used to control the position of airflow regulating dampers, butterfly valves, and other similar process regulating devices on furnaces, boilers and air distribution systems. They are most often used on boiler secondary air (windbox) dampers in NOx reduction control systems.

The LP air cylinders are available with either Buna-N nitrile rubber seals or with Viton seals. The Buna-N seals offer lower internal friction, somewhat longer life, and are suitable over a wider temperature range from 4 to 85 °C (40 to 185 °F). Viton seals, while excellent at temperatures up to and exceeding 121 °C (250 °F), are not suitable for temperatures below freezing.

LP actuators can be supplied with either an AV pneumatic or electro-pneumatic positioner, or a TZIDC or EDP300 digital smart positioner. The AV positioners with 0.2 to 1 bar (3 to 15 psi) or 0.2 to 1.9 bar (3 to 27 psi) control input signals can be supplied with Viton O-rings and fluorosilicone diaphragms, making them suitable for operating temperatures up to 121 °C (250 °F). This same positioner can also be supplied with Buna-N seals suitable for up to 85 °C (185 °F). The positioners are also available in an explosion proof variation. These variations are selectable in the **Ordering information** on page 22.

The LP cylinder sizes range from 63.5 mm (2½ in) diameter × 127 mm (5 in) stroke to 254 mm (10 in) diameter × 406.4 mm (16 in) stroke. The most common sizes, 63.5 × 127 mm (2½ × 5 in) and the 101.6 × 101.6 mm (4 × 4 in), are typically available on short turn-around.

TZIDC and EDP300 digital features and benefits

- Microprocessor-based
- Highest operating accuracy
- Local keypad, with LCD and mechanical position indicator
- Easy local configuration operation
- Configurable operating parameters
- Easy set-up of direct/reverse action, limit stops, etc.
- Integrated position feedback option
- Diagnostics and self-monitoring capabilities
- Easy trouble-shooting and preventive maintenance
- Immunity to shock and vibration
- Installation in high vibration areas

Thrust ratings

The basic thrust rating of a pneumatic piston is equal to the area of the piston multiplied by the supply pressure. The minimum supply pressure to the positioner on the LP actuator should not be less than 276 kPa (2.7 bar) (40 psi).

The maximum supply pressure for the TZIDC should not exceed 600 kPa (6 bar) (90 psi). The maximum supply pressure for the AV and EDP300 positioners should not exceed 1000 kPa (10 bar) (145 psi).

The area of the piston is $A = \pi D^2/4$. Subtract about 10 % for friction losses and because the rod side of the piston has less area. Then multiply this area by the supply pressure in bar (psi). An example is given below for a 5.5 bar (80 psi) air supply.

Notes.

- To find the lever length for 90° rotation, multiply the cylinder stroke length by 0.707.
- Torque equals thrust in Newtons (lbf) multiplied by the lever radius in meters (ft).

Operating torque/thrust characteristic	LP10	LP20	LP30	LP32	LP40	LP50	LP60
Area-retracting (rod side)	30.39 cm ² (4.71 in ²)	72.26 m ² (11.2 in ²)	172.9 m ² (26.8 in ²)	172.9 m ² (26.8 in ²)	314.84 m ² (48.8 in ²)	314.84 m ² (48.8 in ²)	490.97 m ² (76.1 in ²)
Area-extending (other side)	31.68 cm ² (4.91 in ²)	77.03 cm ² (11.94 in ²)	182.58 m ² (28.3 in ²)	182.58 m ² (28.3 in ²)	324.52 m ² (50.3 in ²)	324.52 m ² (50.3 in ²)	506.45 m ² (78.5 in ²)
Force out @ 5.5 bar (80 psi) ¹	1508 N (339 lbs)	3585 N (806 lbs)	8585 N (1930 lbs)	8585 N (1930 lbs)	15,631 N (3514 lbs)	15,631 N (3514 lbs)	24,372 N (5479 lbs)
Lever length for 90° rotation	89.92 mm (3.54 in)	71.88 mm (2.83 in)	143.76 mm (5.66 in)	287.53 mm (11.32 in)	143.76 mm (5.66 in)	287.53 mm (11.32 in)	287.53 mm (11.32 in)
Operating torque @ 5.5 bar (80 psi) ²	92.26 N·m (71 lbf·ft)	181.68 N·m (134 lbf·ft)	871.79 N·m (643 lbf·ft)	1743.58 N·m (1286 lbf·ft)	1589.02 N·m (1172 lbf·ft)	3173.97 N·m (2341 lbf·ft)	4950.09 N·m (3651 lbf·ft)

¹ Use the rod side area × bar (psi) to calculate force. Subtract 10 % for friction loss.

² Torque at mid-stroke is 1.4 × torque at ±45°

Suggested maximum operating force at minimum and maximum supply pressure

Note. The torque calculation values are provided based on the stroke length of the LP and the required lever arm dimension for 90° damper travel.

LP10		
Cylinder diameter × length	63.5 × 127 mm (2.5 × 5 in)	
Lever for 90°	89.66 mm (3.54 in)	
Supply pressure kPa (psi)	Force kN (lbf)	Torque Nm (lbf-ft)
276 (40)	0.75 (170)	48 (35)
310 (45)	0.85 (191)	54 (40)
345 (50)	0.94 (212)	60 (44)
379 (55)	1.04 (233)	66 (48)
414 (60)	1.13 (254)	72 (53)
448 (65)	1.23 (276)	78 (57)
483 (70)	1.32 (297)	84 (62)
517 (75)	1.41 (318)	90 (66)
552 (80)	1.51 (339)	96 (71)
586 (85)	1.60 (360)	102 (75)
621 (90)	1.70 (382)	108 (79)

LP32		
Cylinder diameter × length	152.4 × 406.4 mm (6 × 16 in)	
Lever for 90°	287.27 mm (11.31 in)	
Supply pressure kPa (psi)	Force kN (lbf)	Torque Nm (lbf-ft)
276 (40)	4.29 (965)	872 (643)
310 (45)	4.83 (1,085)	981 (723)
345 (50)	5.36 (1,206)	1,090 (804)
379 (55)	5.90 (1,327)	1,199 (884)
414 (60)	6.44 (1,447)	1,307 (964)
448 (65)	6.97 (1,568)	1,416 (1,045)
483 (70)	7.51 (1,688)	1,525 (1,125)
517 (75)	8.05 (1,809)	1,634 (1,205)
552 (80)	8.58 (1,930)	1,743 (1,286)
586 (85)	9.12 (2,050)	1,852 (1,366)
621 (90)	9.66 (2,171)	1,961 (1,447)

LP60		
Cylinder diameter × length	254 × 406.4 mm (10 × 16 in)	
Lever for 90°	287.27 mm (11.31 in)	
Supply pressure kPa (psi)	Force kN (lbf)	Torque Nm (lbf-ft)
276 (40)	12.19 (2,740)	2,475 (1,826)
310 (45)	13.71 (3,082)	2,784 (2,054)
345 (50)	14.23 (3,425)	3,094 (2,282)
379 (55)	16.76 (3,767)	3,403 (2,510)
414 (60)	18.28 (4,109)	3,713 (2,738)
448 (65)	19.80 (4,452)	4,022 (2,966)
483 (70)	21.33 (4,794)	4,331 (3,195)
517 (75)	22.85 (5,137)	4,641 (3,423)
552 (80)	24.37 (5,479)	4,950 (3,651)
586 (85)	25.90 (5,822)	5,260 (3,879)
621 (90)	27.42 (6,164)	5,569 (4,107)

LP20		
Cylinder diameter × length	101.6 × 101.6 mm (4 × 4 in)	
Lever for 90°	71.88 mm (2.83 in)	
Supply pressure kPa (psi)	Force kN (lbf)	Torque Nm (lbf-ft)
276 (40)	1.79 (403)	91 (67)
310 (45)	2.02 (454)	103 (76)
345 (50)	2.24 (504)	114 (84)
379 (55)	2.47 (554)	125 (92)
414 (60)	2.69 (605)	137 (101)
448 (65)	2.91 (655)	148 (109)
483 (70)	3.14 (706)	160 (118)
517 (75)	3.36 (756)	171 (126)
552 (80)	3.59 (806)	182 (134)
586 (85)	3.81 (857)	194 (143)
621 (90)	4.04 (907)	205 (151)

LP40		
Cylinder diameter × length	203.2 × 203.2 mm (8 × 8 in)	
Lever for 90°	143.76 mm (5.66 in)	
Supply pressure kPa (psi)	Force kN (lbf)	Torque Nm (lbf-ft)
276 (40)	7.81 (1,757)	794 (586)
310 (45)	8.79 (1,976)	894 (659)
345 (50)	9.77 (2,196)	993 (732)
379 (55)	10.75 (2,416)	1,092 (806)
414 (60)	11.72 (2,635)	1,191 (879)
448 (65)	12.70 (2,855)	1,291 (952)
483 (70)	13.68 (3,074)	1,390 (1,025)
517 (75)	14.65 (3,294)	1,489 (1,098)
552 (80)	15.63 (3,514)	1,589 (1,172)
586 (85)	16.61 (3,733)	1,688 (1,245)
621 (90)	17.58 (3,953)	1,787 (1,318)

LP30		
Cylinder diameter × length	152.4 × 203.2 mm (6 × 8 in)	
Lever for 90°	143.76 mm (5.66 in)	
Supply pressure kPa (psi)	Force kN (lbf)	Torque Nm (lbf-ft)
276 (40)	4.29 (965)	436 (322)
310 (45)	4.83 (1,085)	491 (362)
345 (50)	5.36 (1,206)	545 (402)
379 (55)	5.90 (1,327)	600 (442)
414 (60)	6.44 (1,447)	654 (483)
448 (65)	6.97 (1,568)	709 (523)
483 (70)	7.51 (1,688)	763 (563)
517 (75)	8.05 (1,809)	818 (603)
552 (80)	8.58 (1,930)	872 (643)
586 (85)	9.12 (2,050)	927 (684)
621 (90)	9.66 (2,171)	981 (724)

LP50		
Cylinder diameter × length	203.2 × 406.4 mm (8 × 16 in)	
Lever for 90°	287.27 mm (11.31 in)	
Supply pressure kPa (psi)	Force kN (lbf)	Torque Nm (lbf-ft)
276 (40)	7.81 (1,757)	1,587 (1,171)
310 (45)	8.79 (1,976)	1,786 (1,317)
345 (50)	9.77 (2,196)	1,984 (1,463)
379 (55)	10.75 (2,416)	2,182 (1,610)
414 (60)	11.72 (2,635)	2,381 (1,756)
448 (65)	12.70 (2,855)	2,579 (1,902)
483 (70)	13.68 (3,074)	2,778 (2,049)
517 (75)	14.65 (3,294)	2,976 (2,195)
552 (80)	15.63 (3,514)	3,174 (2,341)
586 (85)	16.61 (3,733)	3,373 (2,488)
621 (90)	17.58 (3,953)	3,571 (2,634)

Positioner options for LP actuator

The following overview provides brief information on the positioner that can be selected with the LP actuator – see **Positioner type** on page 22 .

AV15

Input: 0.2 to 1 bar (3 to 15 psi)
 Max. supply pressure: 10 bar (145 psi)
 Temperature limits: 121 °C (250 °F) max.
 Model code of AV15 used in LP: AV152000_

AV16

Input: 0.2 to 1.86 bar (3 to 27 psi)
 Max. supply pressure: 10 bar (145 psi)
 Temperature limits: 121 °C (250 °F) max.
 Model code of AV16 used in LP: AV162000_

AV23

Input: 4 to 20 mA
 Max. supply pressure: 10 bar (145 psi)
 Temperature limits: –20 to 82 °C (–4 to 180 °F)
 Model code of AV23 used in LP: AV232_0_

AV11

Input: 0.2 to 1 bar (3 to 15 psi)
 Max. supply pressure: 10 bar (145 psi)
 Temperature limits: –40 to 180 °C (–40 to 180 °F)
 Model code of AV11 used in LP: AV112_0_

AV12

Input: 0.2 to 1.86 bar (3 to 27 psi)
 Max. supply pressure: 10 bar (145 psi)
 Temperature limits: –40 to 181 °C (–40 to 180 °F)
 Model code of AV12 used in LP: AV122_0_

TZIDC

Input: 4 to 20 mA HART
 Max. supply pressure: 6 bar (90 psi)
 Temperature limits: –40 to 85 °C (–40 to 185 °F)
 Loss of input signal action: Fail-safe
 Model code of TZIDC in LP: V18345.20.2.0.4.2._._1

TZIDC

Input: 4 to 20 mA HART
 Max. supply pressure: 6 bar (90 psi)
 Temperature limits: –40 to 85 °C (–40 to 185 °F)
 Loss of input signal action: Fail-in-place
 Model code of TZIDC in LP: V18345.20.2.0.5.2._._1

TZIDC-200

Input: 4 to 20 mA HART
 Max. supply pressure: 6 bar (90 psi)
 Temperature limits: –40 to 85 °C (–40 to 185 °F)
 Loss of input signal action: Fail-safe
 Model code of TZIDC in LP: V18348.20.1.2.3.3._._1.1.0

TZIDC-200

Input: 4 to 20 mA HART
 Max. supply pressure: 6 bar (90 psi)
 Temperature limits: –40 to 85 °C (–40 to 185 °F)
 Loss of input signal action: Fail-in-place
 Model code of TZIDC in LP: V18348.20.1.2.4.3._._1.1.0

TZIDC-110

Input: PROFIBUS PA
 Max. supply pressure: 6 bar (90 psi)
 Temperature limits: –40 to 85 °C (–40 to 185 °F)
 Loss of input signal action: Fail-safe
 Model code of TZIDC in LP: V18346.20.3.0.4.2.0._1

TZIDC-110

Input: PROFIBUS PA
 Max. supply pressure: 6 bar (90 psi)
 Temperature limits: –40 to 85 °C (–40 to 185 °F)
 Loss of input signal action: Fail-in-place
 Model code of TZIDC in LP: V18346.20.3.0.5.2.0._1

TZIDC-210

Input: PROFIBUS PA
 Max. supply pressure: 6 bar (90 psi)
 Temperature limits: –40 to 85 °C (–40 to 185 °F)
 Loss of input signal action: Fail-safe
 Model code of TZIDC in LP: V18349.20.1.2.3.3._._1.0

TZIDC-210

Input: PROFIBUS PA
 Max. supply pressure: 6 bar (90 psi)
 Temperature limits: –40 to 85 °C (–40 to 185 °F)
 Loss of input signal action: Fail-in-place
 Model code of TZIDC in LP: V18349.20.1.2.4.3._._1.0

TZIDC-120

Input: FOUNDATION Fieldbus
 Max. supply pressure: 6 bar (90 psi)
 Temperature limits: –40 to 85 °C (–40 to 185 °F)
 Loss of input signal action: Fail-safe
 Model code of TZIDC in LP: V18347.20.4.0.4.2.0._._1

TZIDC-120

Input: FOUNDATION Fieldbus
 Max. supply pressure: 6 bar (90 psi)
 Temperature limits: –40 to 85 °C (–40 to 185 °F)
 Loss of input signal action: Fail-in-place
 Model code of TZIDC in LP: V18347.20.4.0.5.2.0._._1

...Positioner options for LP actuator

TZIDC-220

Input: FOUNDATION Fieldbus
 Max. supply pressure: 6 bar (90 psi)
 Temperature limits: -40 to 85 °C (-40 to 185 °F)
 Loss of input signal action: Fail-safe
 Model code of TZIDC in LP: V18350.20.1.2.3.3._.1.0

TZIDC-220

Input: FOUNDATION Fieldbus
 Max. supply pressure: 6 bar (90 psi)
 Temperature limits: -40 to 85 °C (-40 to 185 °F)
 Loss of input signal action: Fail-in-place
 Model code of TZIDC in LP: V18350.20.1.2.4.3._.1.0

EDP300

Input: 4 to 20 mA (HART)
 Max. supply pressure: 10 bar (145 psi)
 Temperature limits: -40 to 85 °C (-40 to 185 °F)
 Loss of input signal action: Fail-safe

- Model code of EDP300 in LP: EDP300.YO.H.2.S.2.D
- Model code of EDP300 with 4 to 20 mA feedback in LP: add code A1 to end of model code EDP300.YO.H.2.S.2.D
- Model code of EDP300 with microswitches in LP: add code F1 to end of model code EDP300.YO.H.2.S.2.D
- Model code of EDP300 with proximity switches in LP: add code F2 to end of model code EDP300.YO.H.2.S.2.D

EDP300

Input: 4 to 20 mA (HART)
 Max. supply pressure: 10 bar (145 psi)
 Temperature limits: -40 to 85 °C (-40 to 185 °F)
 Loss of input signal action: Fail-in-place

- Model code of EDP300 in LP: EDP300.YO.H.2.F.2.D
- Model code of EDP300 with 4 to 20 mA feedback in LP: add code A1 to end of model code EDP300.YO.H.2.F.2.D
- Model code of EDP300 with microswitches in LP: add code F1 to end of model code EDP300.YO.H.2.F.2.D
- Model code of EDP300 with proximity switches in LP: add code F2 to end of model code EDP300.YO.H.2.F.2.D

Dimensions

LP10 actuator fitted with TZIDC positioner with equalizing manifold

All dimensions in mm (in)

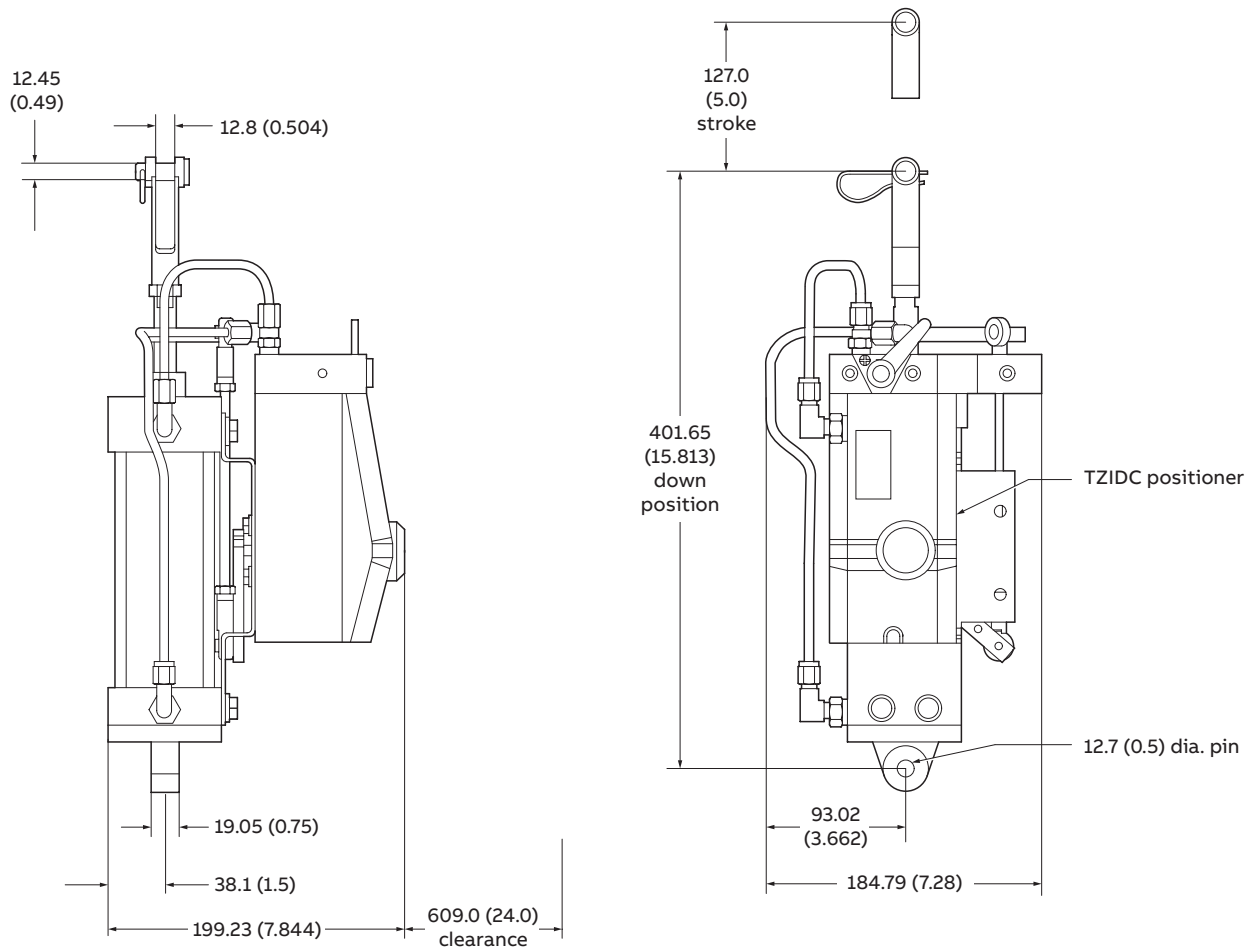

...Dimensions

LP20 actuator fitted with AV positioner with equalizing manifold

All dimensions in mm (in)

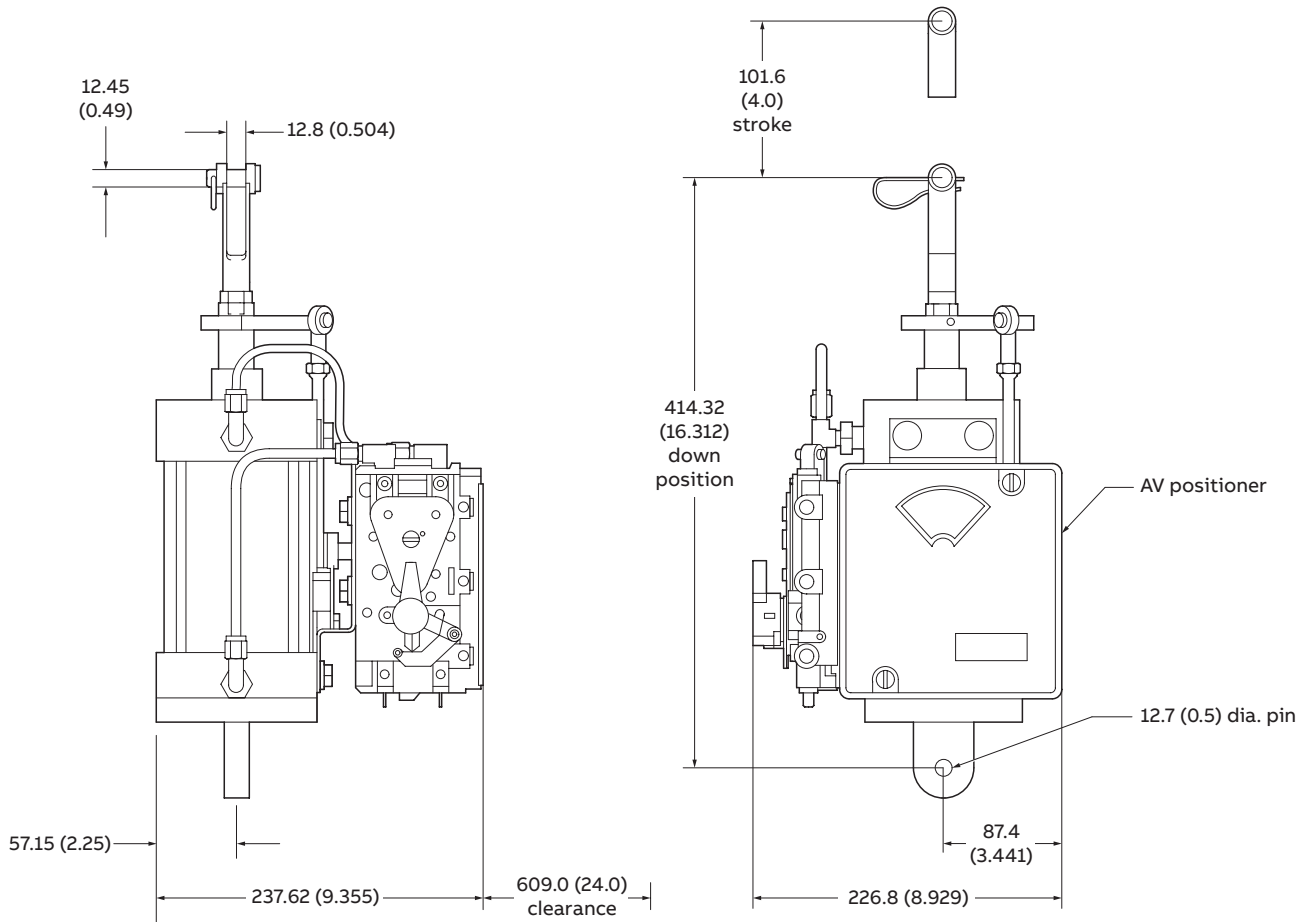

LP20 actuator fitted with AV positioner without manifold

All dimensions in mm (in)

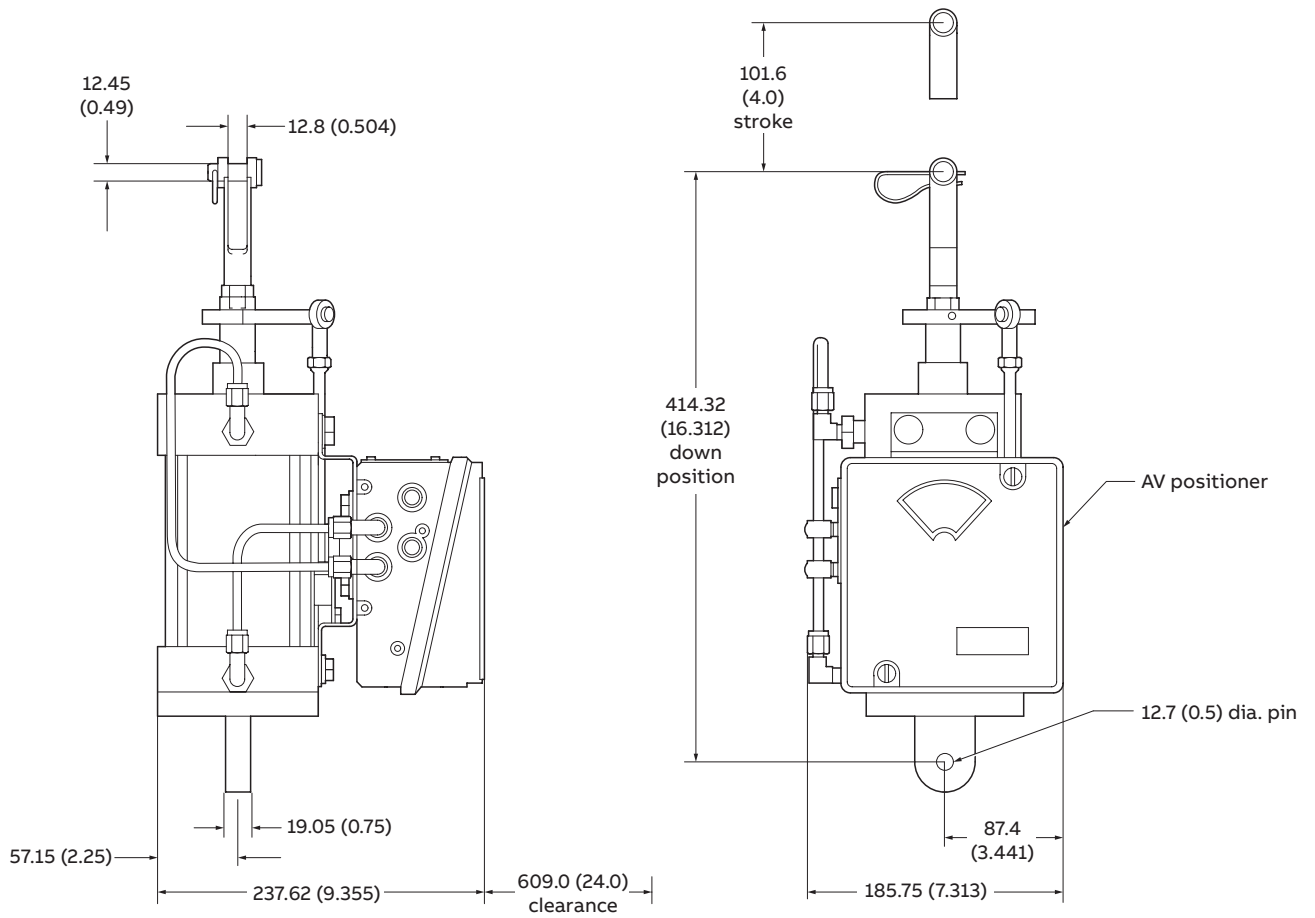

...Dimensions

LP30 actuator fitted with AV positioner with equalizing manifold

All dimensions in mm (in)

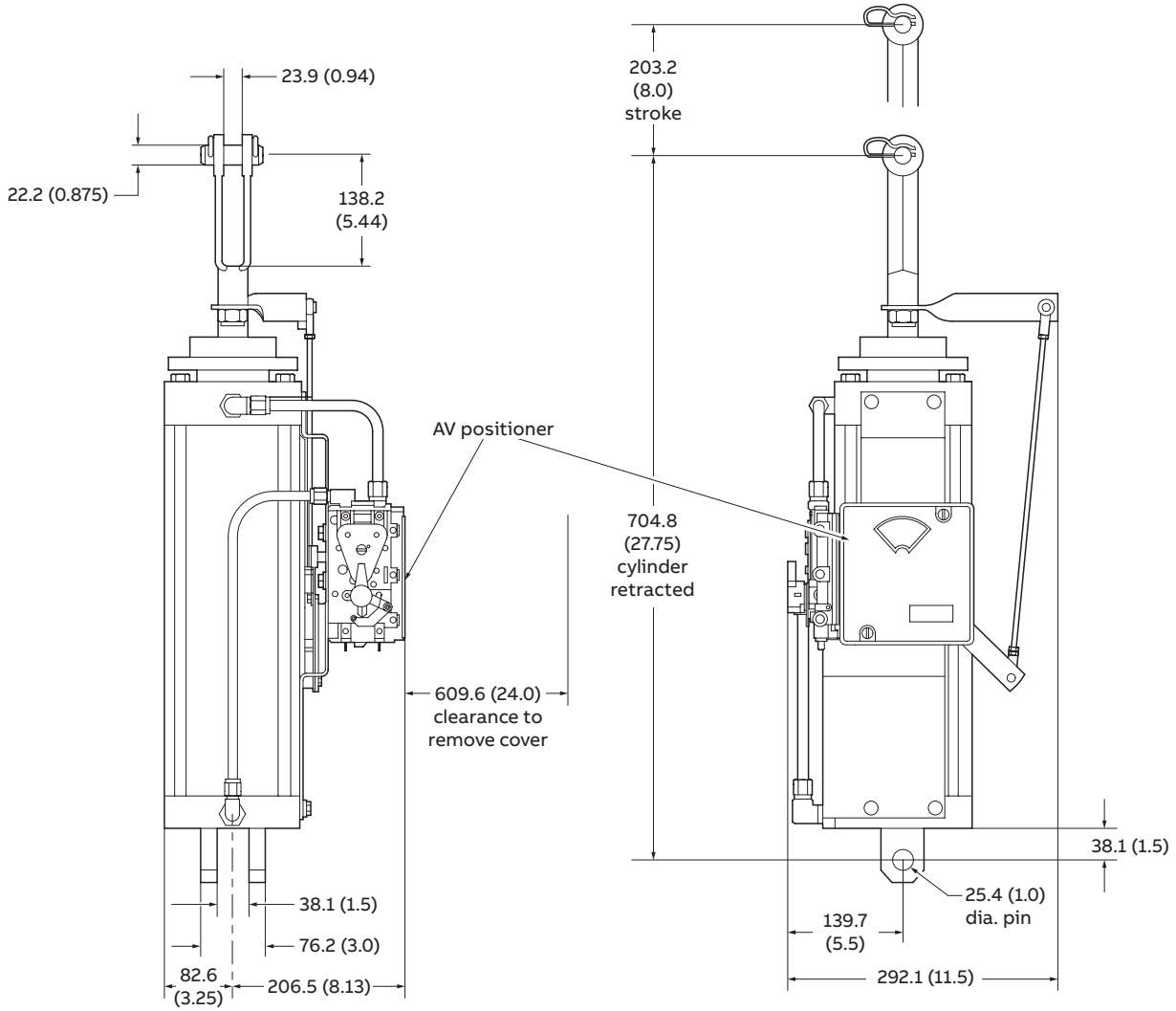

...Dimensions

LP32 actuator fitted with AV positioner with equalizing manifold

All dimensions in mm (in)

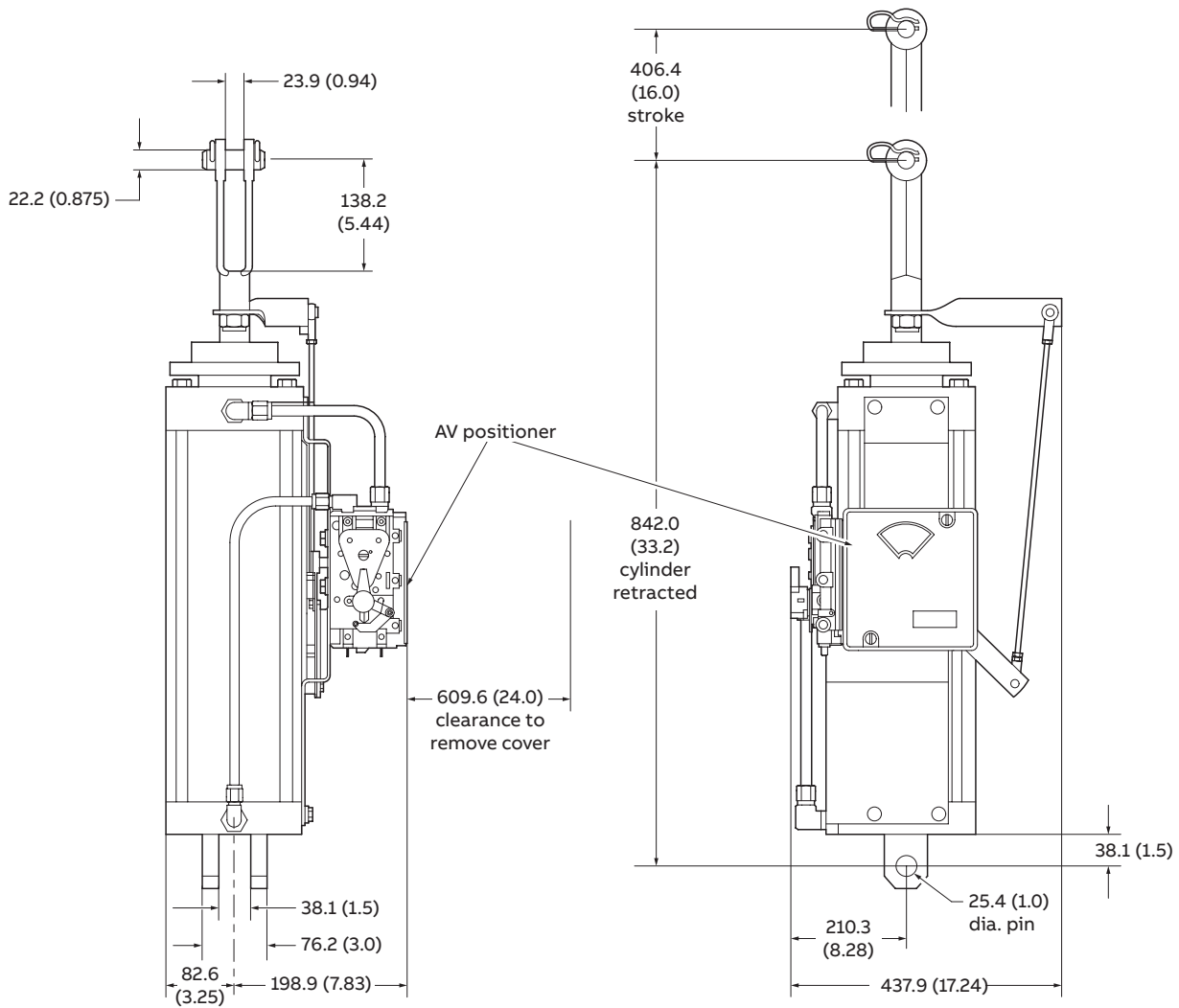

LP32 actuator fitted with TZIDC positioner without manifold

All dimensions in mm (in)

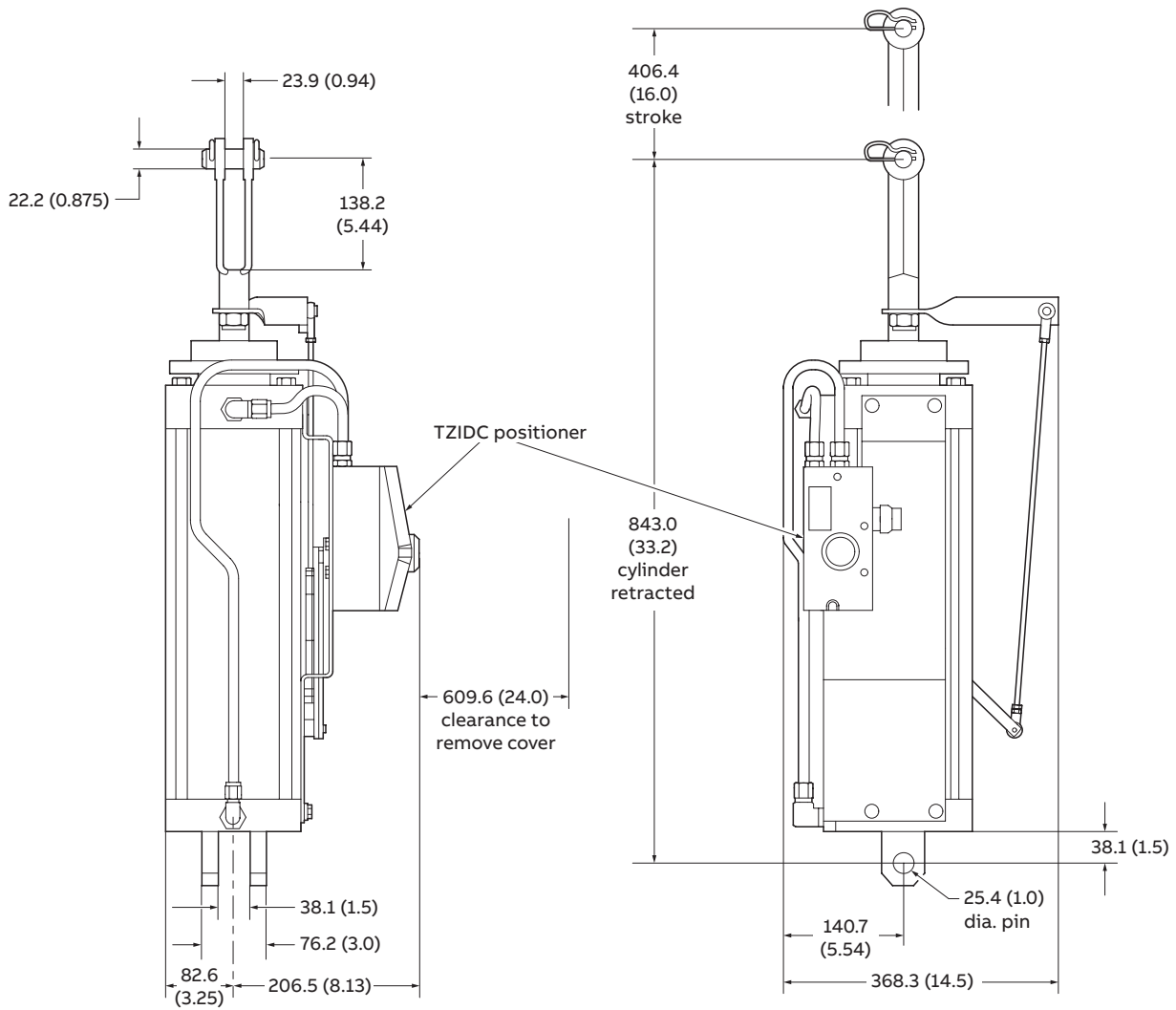

...Dimensions

LP40 actuator fitted with TZIDC positioner without manifold

All dimensions in mm (in)

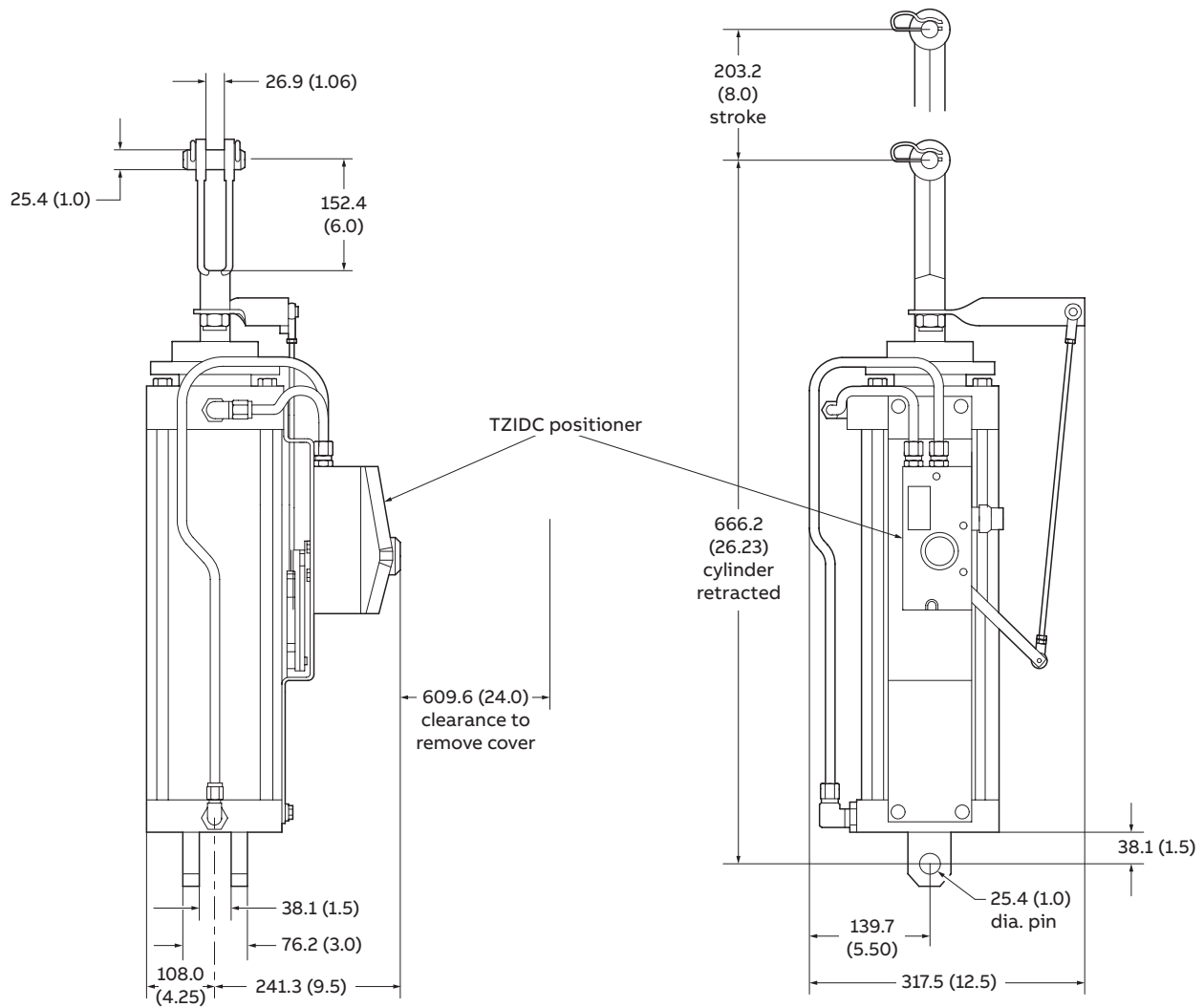

LP40 actuator fitted with AV positioner with equalizing manifold

All dimensions in mm (in)

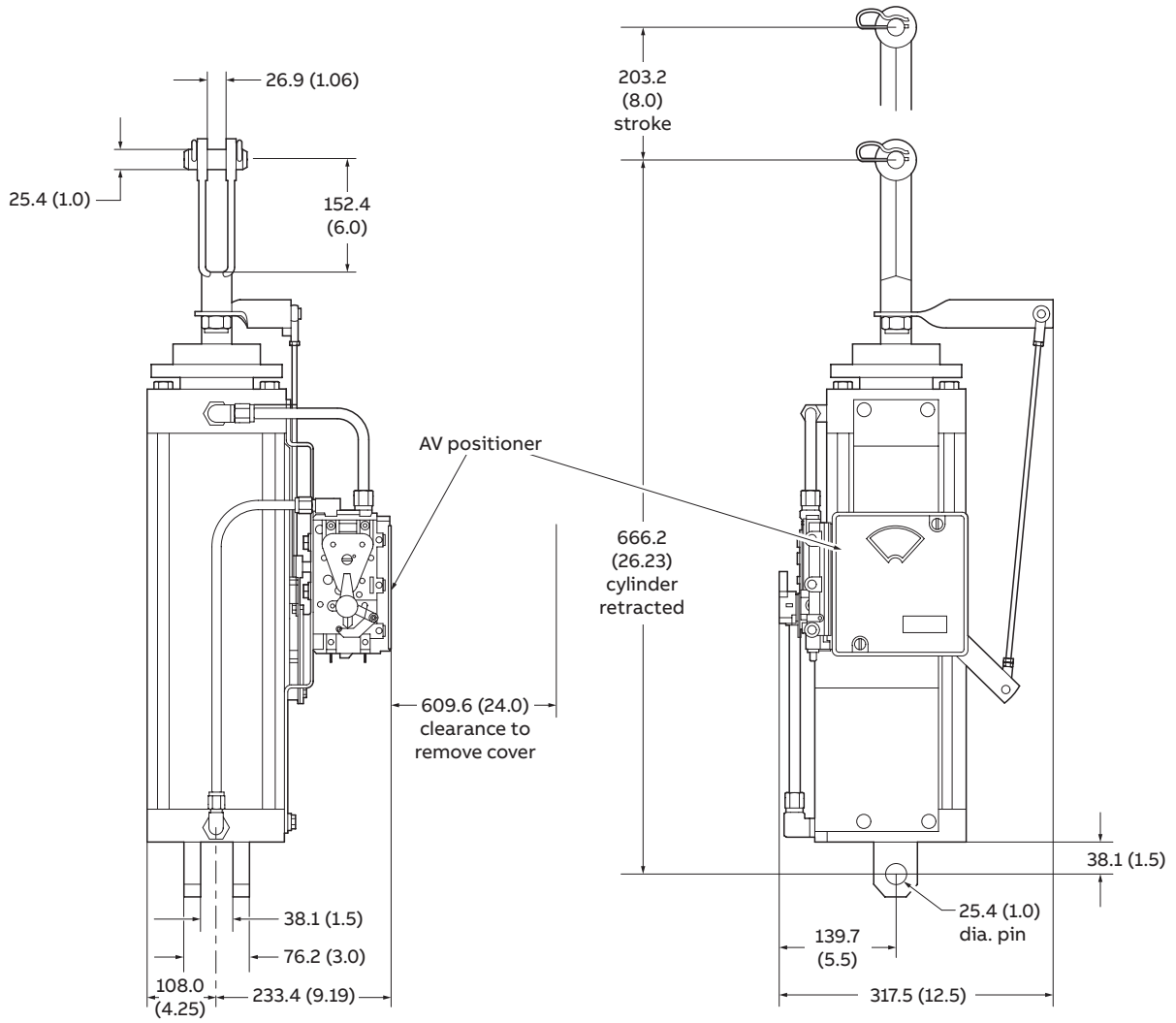

...Dimensions

LP50 actuator fitted with AV positioner with equalizing manifold

All dimensions in mm (in)

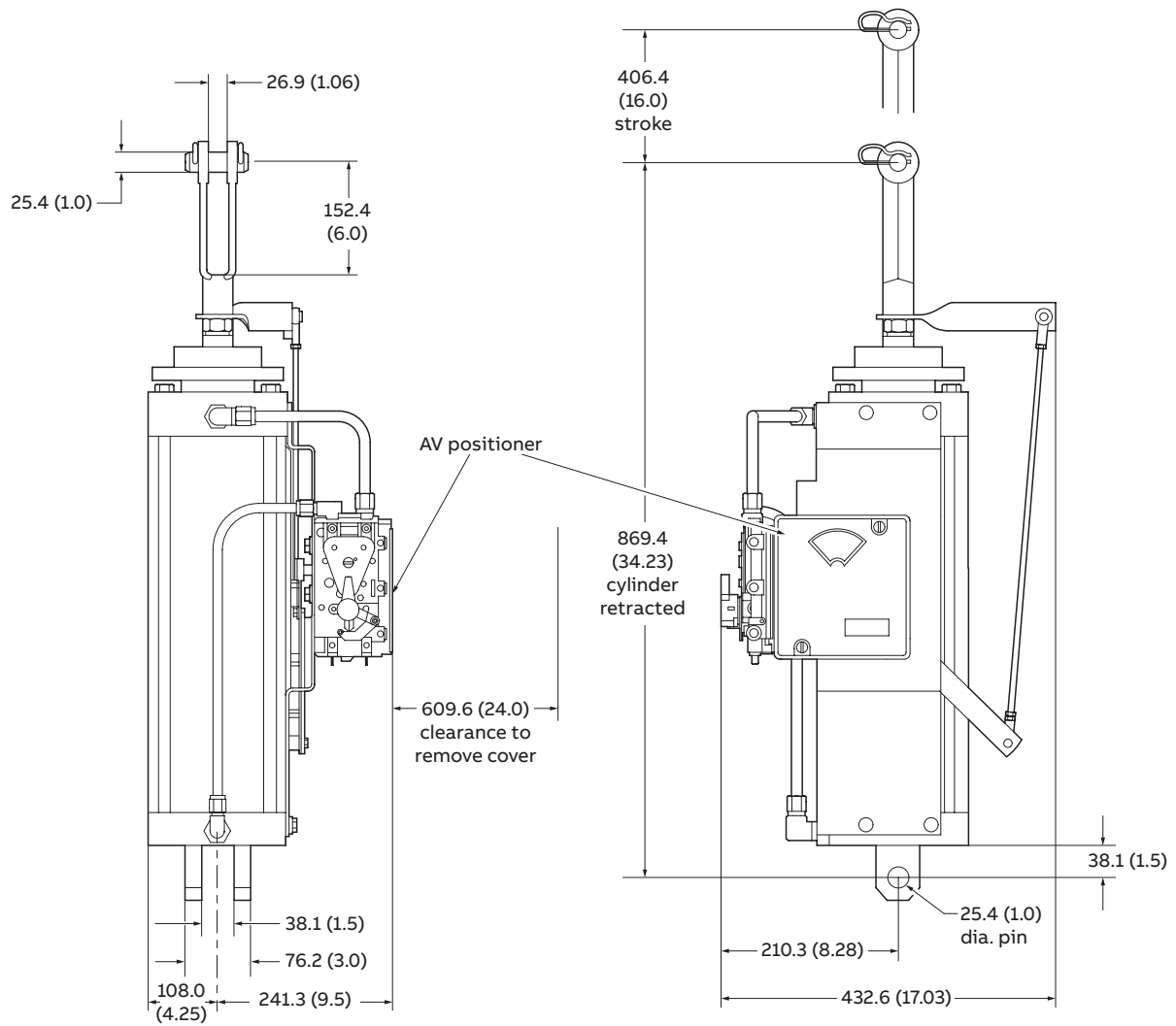

LP50 actuator fitted with TZIDC positioner without manifold

All dimensions in mm (in)

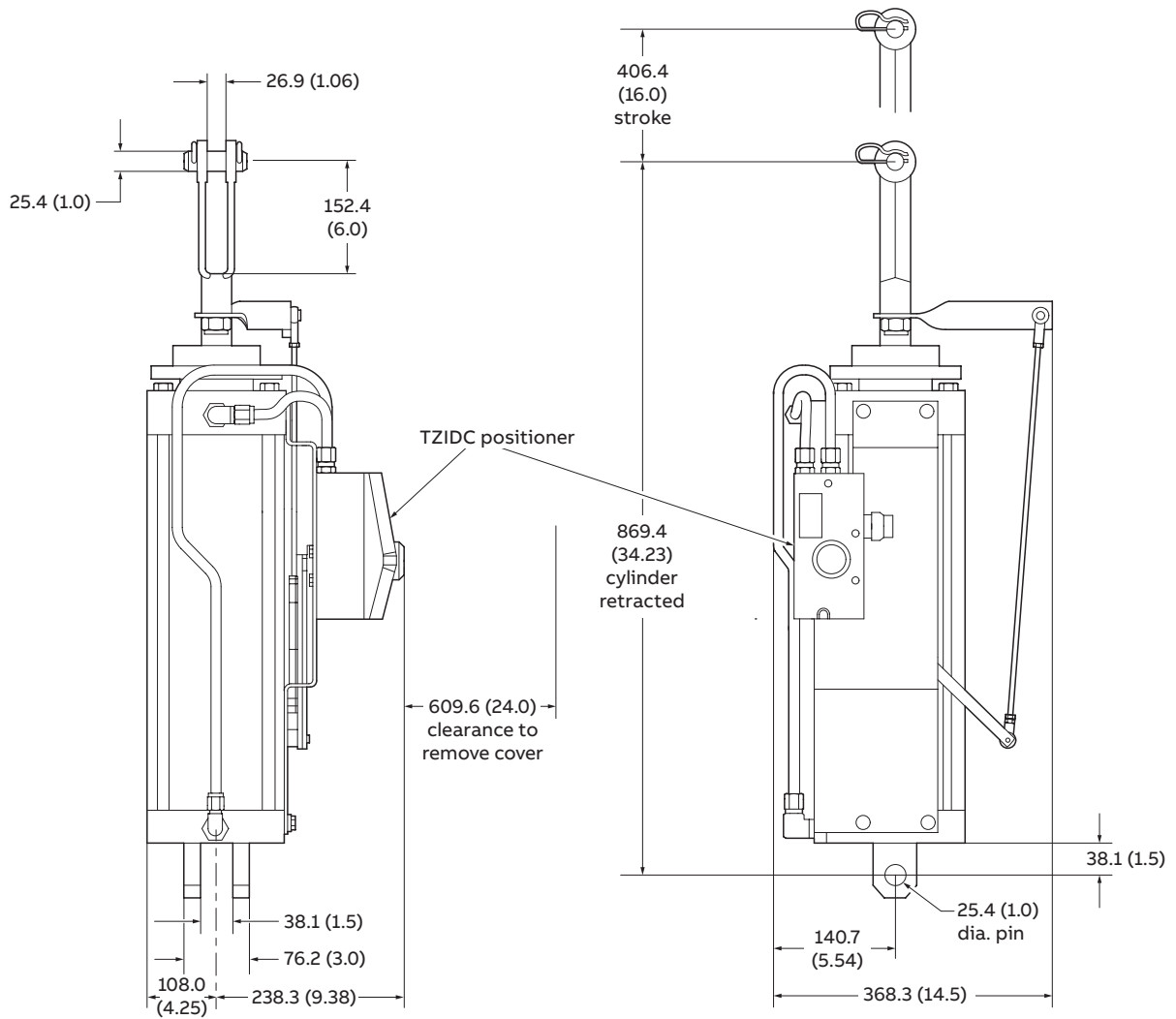

...Dimensions

LP60 actuator fitted with TZIDC positioner without manifold

All dimensions in mm (in)

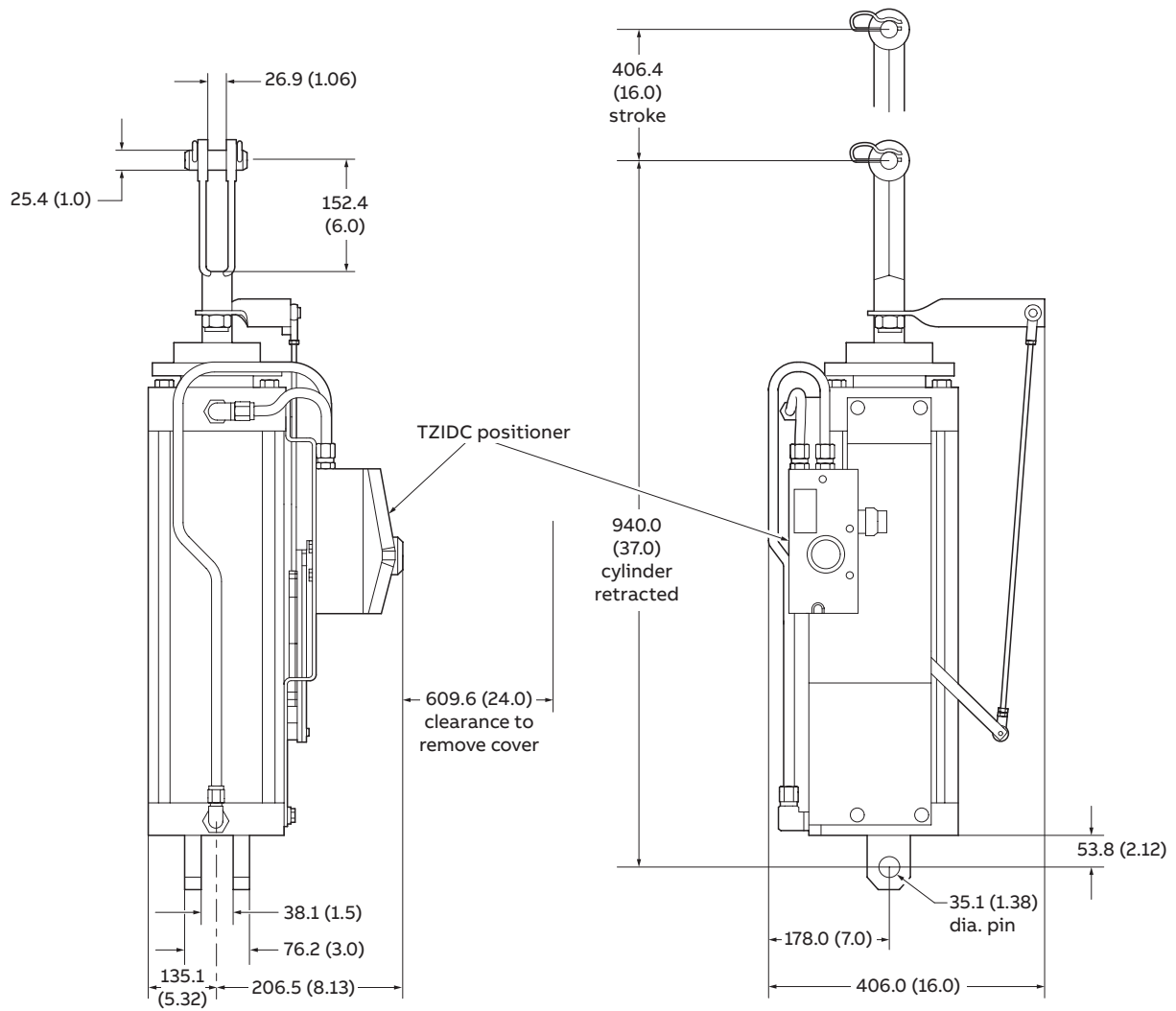

LP60 actuator fitted with AV positioner with equalizing manifold

All dimensions in mm (in)

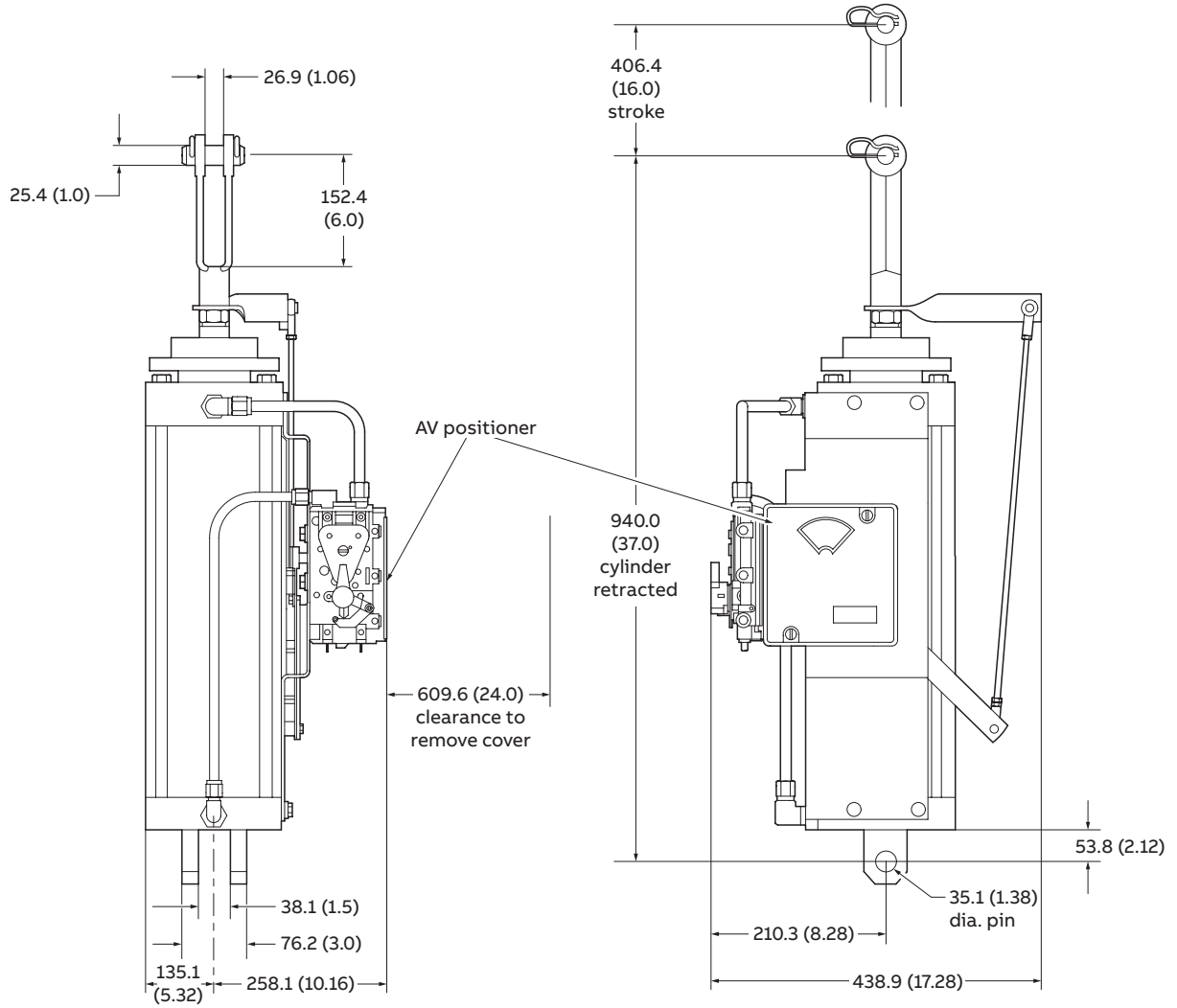

Accessories

Base mount pivot bracket (LP10 and LP20)

All dimensions in mm (in)

Part no.	BA	CB	CD	CW	DD	E	F	FL	L	M
353E435U04 (for LP10 and LP20)	41.4 (1.63)	19 (0.75)	12.7 (0.5)	12.7 (0.5)	9.7 (0.38) × 24 tpi	63.5 (2.5)	9.7 (0.38)	28.7 (1.13)	19 (0.75)	12.7 (0.5)

Material – cast steel
Finish – black oxide

Note. Pivot bracket pins are sold separately from pivot brackets

Base mount pivot bracket (LP30 to LP60)

All dimensions in mm (in)

Part no.	BA	CB	CD	DD	E	F	FL	L	M
353E435U02 (for LP30 to LP50)	82.6 (3.25)	38.1 (1.5)	25.4 (1.0)	16.8 (0.66)	114.3 (4.5)	19 (0.75)	57.2 (2.25)	38.1 (1.5)	25.4 (1.0)
353E435U01 (for LP60)	96.78 (3.81)	50.8 (2.0)	35.1 (1.38)	16.8 (0.66)	127.0 (5.0)	22.4 (0.88)	76.2 (3.0)	54.1 (2.13)	35.1 (1.38)

Material – cast steel
Finish – black oxide

Note. Pivot bracket pins are sold separately from pivot brackets

Pin with bridge pin for pivot bracket (LP10 to LP50)

All dimensions in mm (in)

Part no.	CD	H	HP	LH	LP
398B203U03 (for LP10 and LP20)	12.7 (0.5)	16.0 (0.63)	4.06 (0.16)	57.2 (2.25)	53.1 (2.09)
398B203U02 (for LP30 to LP50)	25.4 (1.0)	30.2 (1.19)	5.08 (0.2)	88.9 (3.5)	84.1 (3.31)

Material – 1018 CRS
Finish – black oxide

Pin with cotter pins for pivot bracket (LP60)

All dimensions in mm (in)

Part no.	CD	LH	LP
398B203U04 (for LP60)	35.0 (1.38)	127.0 (5.0)	108.0 (4.25)

Material – 1045 CRS
Finish – chrome-plated OD

Note. Supplied with 2 cotter pins

Linear pneumatic piston actuator	LP	XX	X	X	X	X	X	X	X
Mounting/Enclosure classification rating	(Note: 10)								
Standard clevis and pivot tab, NEMA 3R for AV, NEMA 4X for TZIDC/EDP300									0
Standard clevis and pivot tab with cylinder shaft protective boot, NEMA 3R for AV, NEMA 4X for TZIDC/EDP300									1
Standard clevis and pivot tab, NEMA 4X for AV									2
Standard clevis and pivot tab with cylinder shaft protective boot, NEMA 4X for AV									3
Tubing									
Tubing with brass fittings	(Note: 11)								
Stainless steel tubing (304) with stainless steel fittings (Parker)									S
Non-standard option									X
Operating instruction									
One copy supplied, at no cost, with order (OI/LP-EN)									

Accessories

Supply pressure alarm switch, adjustable 0 to 6.9 bar (0 to 100 psi) rated 13 amps AC, 0.5 amps DC	(Note: 12)	1941099A1
Supply air coalescing filter, ¼ in 18 NPT for LP10/LP20/LP30/LP32/LP40	(Note: 13)	5328563D2
Supply air regulator with gauge ¼ in 18 NPT for LP10/LP20/LP30/LP32/LP40	(Note: 13)	1951029D5
Supply air regulator/ coalescing filter, with gauge, ½ NPT (high capacity), for LP50/LP60	(Note: 13)	1951439D1
Base mounting pivot brackets LP60		353E435U01
Base mounting pivot brackets LP30/LP32/LP40/LP50		353E435U02
Base mounting pivot brackets LP10/LP20		353E435U04
Pin and retainers for pivot bracket LP30/LP32/LP40/LP50		398B203U02
Pin and retainers for pivot bracket LP10/LP20		398B203U03
Pin and retainers for pivot bracket LP60		398B203U04
Gauge for supply pressure (1 required)	(Note: 9)	5326605A5
Gauges for outlet pressure (2 required)	(Note: 9)	5326605A6

Spares

Cylinder seal kit for LP10B	614B069U22
Cylinder seal kit for LP10V	614B069U23
Cylinder seal kit for LP20B	614B069U24
Cylinder seal kit for LP20V	614B069U25
Cylinder seal kit for LP30B and LP32B	614B069U26
Cylinder seal kit for LP30V and LP32V	614B069U27
Cylinder seal kit for LP40B and LP50B	614B069U28
Cylinder seal kit for LP40V and LP50V	614B069U29
Cylinder seal kit for LP60B	614B069U30
Cylinder seal kit for LP60V	614B069U31

- Note 1 Available only with positioner type 1, 2, 3, 4, 5, U, V
- Note 2 Positioners are general purpose except where noted (see Note 3). Consult factory for hazardous application solutions
- Note 3 Positioner type option C, D, M, N, S, T includes explosion proof hazardous approval FM/CSA Class 1 Div 1 Gr C-D
- Note 4 Direction control refers to stroke direction of cylinder (direct action). Position feedback signal follows the input signal
- Note 5 Not available with positioner code K, L, M, N, P, R, S, T
- Note 6 Not available with positioner code 1, 2
- Note 7 Not available with positioner code 1, 2, 3, 4, 5, K, L, M, N, P, R, S, T
- Note 8 Not available with positioner code 1, 2, 3, 4, 5
- Note 9 Refer to accessories for gauges, supplied separate for field installation
- Note 10 Refer to accessories for mounting base/pin or retainer
- Note 11 All LP10/LP20 are supplied with copper tubing as standard. Larger sizes up to LP60 are supplied with TBG-nylon tubing
- Note 12 Not suitable for hazardous process applications that require FM/CSA approved equipment
- Note 13 Supplied separate for field installation

Acknowledgments

Buna-N is the registered trademark of Pittway Corporation, Chicago.

Viton is a registered trademark of the Chemours Company.

HART and FOUNDATION Fieldbus are registered trademarks of FieldComm Group, Austin, Texas, USA.

PROFIBUS is a registered trademark of PROFIBUS and PROFINET International (PI).

Notes

...Notes

ABB Inc.**Measurement & Analytics**

125 E. County Line Road
Warminster, PA 18974
USA

Tel: +1 215 674 6000
Fax: +1 215 674 7183

ABB Automation Products GmbH**Measurement & Analytics**

Schillerstr. 72
32425 Minden
Germany

Tel: +49 571 830-0
Fax: +49 571 830-1806

abb.com/actuators

ABB Limited**Measurement & Analytics**

Howard Road, St. Neots
Cambridgeshire, PE19 8EU
UK

Tel: +44 (0)870 600 6122
Fax: +44 (0)1480 213 339
Email: instrumentation@gb.abb.com











We reserve the right to make technical changes or modify the contents of this document without prior notice. With regard to purchase orders, the agreed particulars shall prevail.
ABB does not accept any responsibility whatsoever for potential errors or possible lack of information in this document.

We reserve all rights in this document and in the subject matter and illustrations contained therein. Any reproduction, disclosure to third parties or utilization of its contents – in whole or in parts – is forbidden without prior written consent of ABB.

© 2019 ABB.
All rights reserved.



Our offering:

	Actuators and Positioners		Analytical Instruments
	Device Management, Fieldbus and Wireless		Flow Measurement
	Force Measurement		Level Measurement
	Natural Gas Measurement		Pressure Measurement
	Recorders and Controllers		Temperature Measurement

HMI – Automação e Instrumentação, Lda.

Travessa da Indústria, nº 111
4780-573 Santo Tirso
PORTUGAL

Tel. +351 252 850 501
Fax. +351 300 013 487

Web: www.hmi.pt

Email: hmi@hmi.pt