



FICHA TÉCNICA DE PRODUTO

PRODUCT DATASHEET

---

HMI – Automação e Instrumentação, Lda.

---

Rua dos 5 Caminhos, nº 570  
4780-382 Santo Tirso  
PORTUGAL

Tel. +351 252 850 501  
Fax. +351 300 013 487

Web: [www.hmi.pt](http://www.hmi.pt)

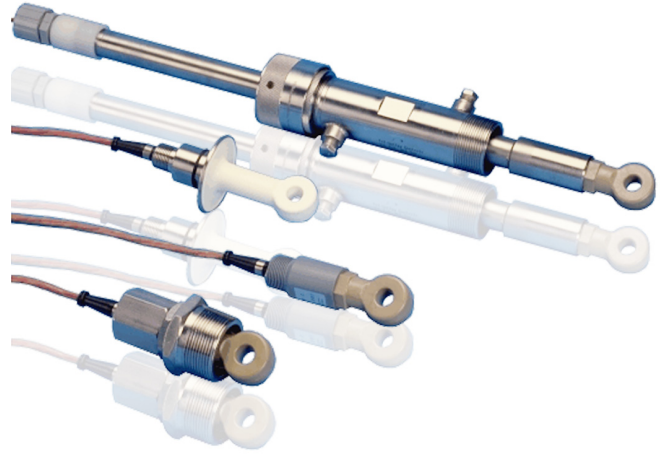
Email: [hmi@hmi.pt](mailto:hmi@hmi.pt)

# TB404

## Conductivity sensors

### Toroidal

Perfect for use in standard to highly corrosive solutions



#### Greatly reduces coating and other fouling problems

- Inductive measurement technique yields a solution conductivity measurement virtually unaffected by solution contaminants

#### Multi-range capability

- Measures from 400  $\mu\text{S}/\text{cm}$  to 2,000  $\text{mS}/\text{cm}$

#### Versatile mounting

- Hardware for submersion, 1½-inch inline, and low and high pressure ball valve insertion

#### Automatic temperature compensator with fast thermal response

#### Small size with large center bore

- Allows 1½-inch mounting, yet center bore is 50% larger than comparatively sized sensors

#### PEEK encapsulation

- Assure chemical resistance and durability

#### High pressure and temperature ratings

- Up to 200°C (392°F), 2,070 kPag (300 psig) depending on mounting hardware and materials

#### 316 stainless steel, Kynar®, titanium, and CPVC hardware

- Available to fit all applications

## General Description

Model TB404 Toroidal Conductivity Sensors expand the advancements in process conductivity measurement initiated by ABB with four-electrode conductivity measurement. Unlike four-electrode sensors, toroidal sensors have no electrodes.

The Model TB404 Toroidal Conductivity Sensor provides a means for measuring solution conductivity in chemically aggressive solutions that corrode, foul, or otherwise destroy electrode type sensors. The sensor itself is comprised of two wound toroids encapsulated in a chemically resistant nonconductor made of polyether-ether ketone (PEEK). Measurement is made inductively via magnetic coupling between the solution and the toroids. Because measurement is made inductively, without electrodes that can be affected by erroneous resistances from foulants or coatings, these sensors are virtually impervious to all but thick layers of foulants.

Toroidal conductivity measurement is applicable to a wide variety of industrial process needs including: sewer and condensate monitoring, pulping and sugar liquors, chemical concentration monitoring, liquids containing algae, cleaning and clean-in-place solutions, food and pharmaceutical installations, liming applications, brine, solutions with solids and/or high ionic strength, and countless other applications.

## Toroidal Conductivity Theory

Toroidal (sometimes referred to as electrodeless or inductive) conductivity measurement is performed without using any electrodes in contact with the solution. Instead the sensor is comprised of two wound toroids encapsulated in PEEK.

The conductivity instrument supplies a constant drive to one of the two toroids. This drive toroid generates a strong magnetic field in the solution. Since the solution forms a continuous loop around the two toroids, the current induced into the solution by this drive toroid couples with the second toroid. This second or sense toroid then emits a current that varies directly with the amount of coupling occurring through the solution. Since the induced current varies proportionally with the conductance of the solution, the signal measured by the sense toroid is directly related to solution conductivity.

Toroidal conductivity measurement is made through a nonconductive material, so it is not affected by coatings or scales that add resistance and error to conventional conductivity measurements. Only when coatings accumulate thick enough to significantly obscure the cross sectional area of the solution loop is the toroidal measurement compromised.

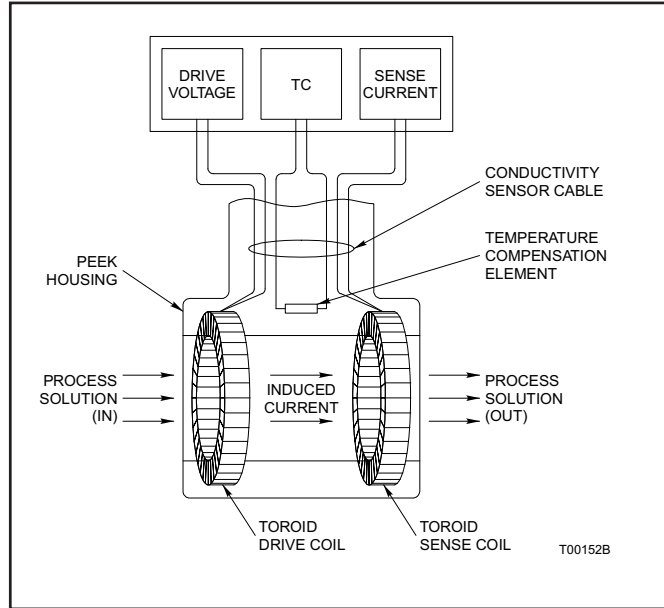


Figure 1. Toroidal Conductivity Measurement

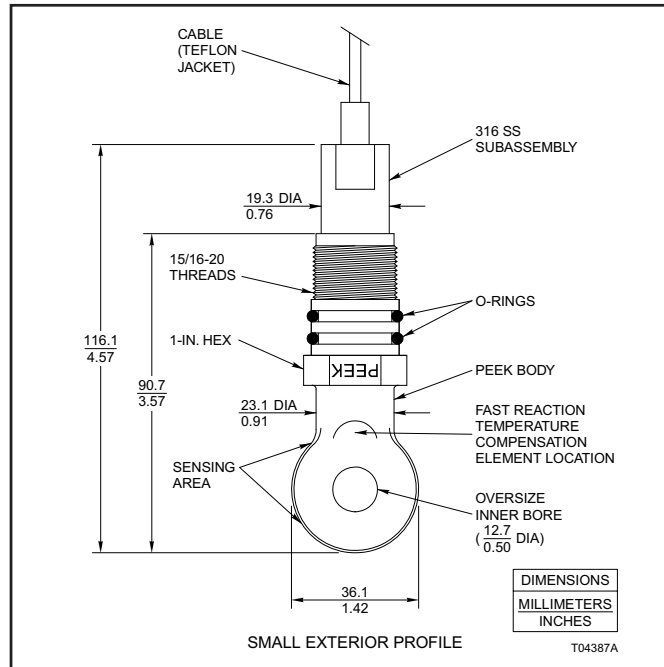


Figure 2. TB404 Toroidal Conductivity Sensor

## Materials

The wetted area of the Model TB404 Toroidal Conductivity Sensor is completely encapsulated in PEEK, one of the most durable thermoplastics used in industry. The interior of the sensor contains 316 stainless steel and high temperature epoxy assuring compatibility with all processes. With such combinations of material, the Model TB404 Toroidal Conductivity Sensor gives bullet-proof performance and reliability.

## Temperature Compensation

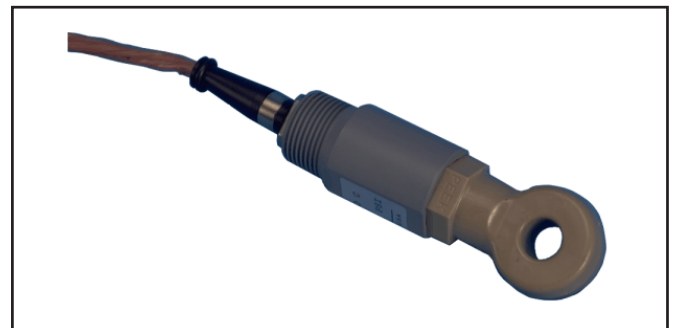
Solution conductivity is greatly affected by temperature. Compensation for the affects of temperature on solution conductivity (temperature compensation) is accomplished by a resistive temperature detector (RTD) in the sensor and circuitry in the associated instrument. Temperature response of the sensor is excellent as the RTD is placed directly in the process with the sensor toroids. Only extremely durable RTDs, rated well above the 200-degree Celsius (392-degree Fahrenheit) sensor rating, are used to ensure total reliability.

## Submersible

The sensor is readily adaptable to submersion applications. Order the sensor with a CPVC, 316 stainless steel, or Kynar submersible adapter. The adapter has a female thread that matches the rear threads of the sensor and a male 3/4 NPT for attachment to a 3/4-inch submersion rod. The rod (or pipe) is required for protecting the sensor cable and for holding the sensor in a fixed, submersed position.

The submersion style is used for measurement in open streams, containers, ponds, basins, lagoons, and similar locations. It can also be used for top mounting into sealed containers.

<b>Range</b>	Min 0 to 400 $\mu$ S/cm Max. 0 to 2,000 mS/cm depending on instrument chosen
<b>Temperature</b>	Max. 200°C (392°F) with 316 Stainless Steel adapter  Max. 140°C (284°F) with Kynar adapter  Max. 80°C (176°F) with CPVC adapter
<b>Pressure</b>	Max. 689 kPag (100 psig)



**Figure 3.** Model TB404 with PVC Submersible Adapter

## High Pressure Ball Valve Insertion

Model TB404 High Pressure Ball Valve Insertion (Hot Tap) Sensor allows direct installation of the sensor in process lines and vessels above 2068 kPa (300 psi). The sensor is installed through a 1½-inch full port ball valve. It can be safely inserted or removed without draining or depressurizing the process piping or vessel.

This sensor assembly differs from the low pressure version by the size of the insertion rod and addition of a retraction chamber. A ½-inch diameter insertion rod is held in place by a compression fitting. The small diameter allows insertion at high pressures despite the large size of the sensor because the difference in pressure is only across the ½-inch cross sectional area of the rod.

The sensor is retracted into a chamber that contains two ¼-NPT flushing ports that allow purging of solids and/or hazardous chemicals. The ports can also be used for pressurizing the assembly before insertion.

**Range** Min 0 to 400 µS/cm  
Max. 0 to 2,000 mS/cm  
depending on instrument chosen

**Temperature** Max. 150°C (302°F)

**Pressure** Max. 2,070 kPag (300 psig)

**Seals** Teflon™ ferrule in compression fitting, O-rings per sensor nomenclature

**Materials** 316 Stainless Steel and titanium

### Process Connection

1½-NPT with ABB-supplied valve:  
(titanium ball valve supplied by customer)



Figure 4. High Pressure Ball Valve Insertion Sensor

## Inline Flow Sensor

The inline flow adapter allows simple mounting of the Model TB404 sensor inside process piping or vessels. Available in CPVC, 316 stainless steel, or titanium versions, this three piece adapter has an integral 1½-NPT male process connection.

The TB404 sensor mounts inside the flow adapter via its rear threads. The O-rings on the sensor provide a seal from the process. A retainer nut is used to align the sensor to the process flow and hold the sensor in the adapter. A Viton® gasket is used to seal this retainer.

**Range** Min 0 to 400 µS/cm  
Max. 0 to 2,000 mS/cm  
depending on instrument chosen

**Temperature** Max. 200°C (392°F) with  
316 Stainless Steel adapter  
Max. 200°C (392°F) with  
titanium adapter  
Max. 65°C (149°F) with  
CPVC adapter

**Pressure** Max. 2,070 kPag (300 psig)  
for 316 Stainless Steel  
Max. 2,070 kPag (300 psig)  
for titanium  
Max. 689 kPag (100 psig)  
for CPVC



Figure 5. Model TB404 with Inline Flow Adapter

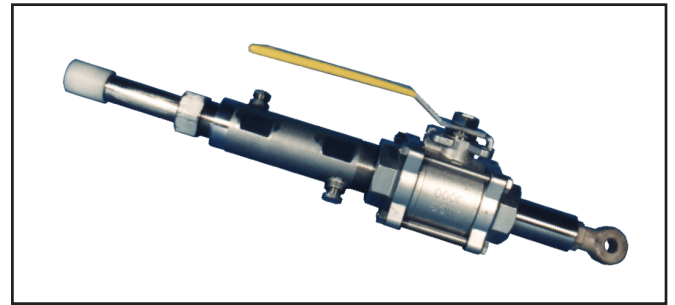
\* TEFLON® is a registered trademark of DuPont.

## Low Pressure Ball Valve Insertion

The Model TB404 Low Pressure Ball Valve Insertion (Hot Tap) Sensor allows simple installation of the sensor in process lines and vessels. The sensor is installed through a 1½-inch full port or two-inch ball valve. It can be safely inserted or removed from the process without draining or depressurizing the piping or vessel.

The sensor fits into a one-inch diameter insertion rod and is sealed into it by its O-rings. The insertion rod is held in place by a compression fitting that screws into the valve. Two types of compression fitting are available; a wrench type that requires that the fitting be taken out of the valve before the sensor assembly can be removed and a hand tight fitting that allows a quick disconnect from the process without tools. Both compression fittings have two ¼-NPT ports that allow flushing of the assembly to remove solids and/or hazardous chemicals. The ports can also be used for pressurizing the assembly to make insertion easier.

<b>Range</b>	Min 0 to 400 µS/cm Max. 0 to 2,000 mS/cm depending on instrument chosen
<b>Temperature</b>	Max. 150°C (302°F)
<b>Pressure</b>	Max. 689 kPag (100 psig)
<b>Seals</b>	Teflon® ferrule in compression fitting, O-rings per sensor nomenclature
<b>Materials</b>	316 Stainless Steel and titanium
<b>Process Connection</b>	1½-NPT with ABB-supplied valve: (titanium ball valve supplied by customer)



**Figure 6.** Low Pressure Ball Valve Insertion with Wrench Tight Compression Fitting



**Figure 7.** Low Pressure Ball Valve Insertion with Hand Tight Compression Fitting without Valve

\* TEFLON® is a registered trademark of DuPont.

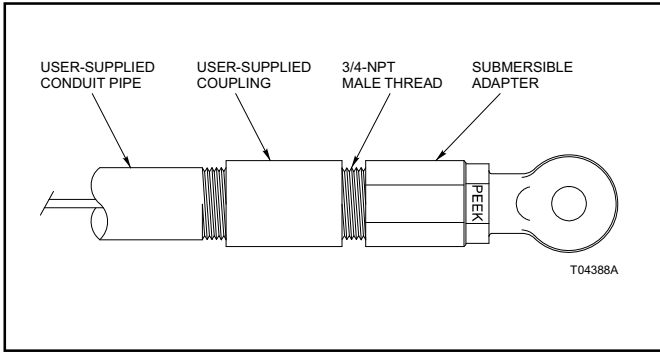
Ordering Information	Model Code		TB404	—	—	—	—	—	—	—	—	—		
	01 - 05	06	07	08	09	10	11	12	13					
<b>Toroidal Conductivity Sensor</b>														
<b>Sensor Style</b>														
Standard with 15/16" - 20 Threads, PEEK											2			
<b>Integral Thermocompensator</b>														
Pt 1000											2			
<b>O-Ring Material</b> (Note 3)														
EPDM (for TB4042 only)											1			
Viton (for TB4042 only)											2			
Kalrez (for flow, submers, or replacement sensors) (for TB4042 only)											3			
Kalrez (for Hot Tap Sensors)											4			
<b>Hardware</b> (Note 3, 6)														
Submersible Adapter, 3/4" MNPT, CPVC											S	1		
Submersible Adapter, 3/4" MNPT, 316 Stainless Steel											S	2		
Submersible Adapter, 3/4" MNPT, Kynar											S	3		
In-Line Flow, 1-1/2" MNPT, CPVC											F	1		
In-Line Flow, 1-1/2" MNPT, 316 Stainless Steel											F	2		
In-Line Flow, 1-1/2" MNPT, Titanium											F	3		
Low Pressure Hot Tap w/o Valve, Wrench-Tight Compression Fitting, 316 Stainless Steel*											L	1		
Low Pressure Hot Tap w/o Valve, Hand-Tight Compression Fitting, 316 Stainless Steel*											L	2		
Low Pressure Hot Tap w/o Valve, Wrench-Tight Compression Fitting, Titanium											L	3		
Low Pressure Hot Tap w/o Valve, Hand-Tight Compression Fitting, Titanium *											L	4		
High Pressure Hot Tap w/ Valve, 316 Stainless Steel*											H	1		
High Pressure Hot Tap w/ Valve, Titanium*											H	3		
* Notes 3 & 6 Apply														
<b>Low Pressure Hot Tap Insertion Rod (Note 5)</b>														
None												0		
20", 316 Stainless Steel												1		
24", 316 Stainless Steel												2		
30", 316 Stainless Steel												3		
36", 316 Stainless Steel												4		
20", Titanium - Grade 2												5		
24", Titanium - Grade 2												6		
30", Titanium - Grade 2												7		
36", Titanium - Grade 2												8		

Model Code	TB404	—	—	—	—	—	—	—	—
	01 - 05	06	07	08	09	10	11	12	13
<b>Cable Length</b> (Note 7)									
5 ft. (1.5m)									1
10 ft. (3 m)									2
15 ft. (4.6 m)									3
20 ft. (6.1 m)									4
30 ft. (9.1 m)									5
40 ft. (12.2 m)									6
50 ft. (15.2 m)									7
<b>Identification Tag</b>									
None									0
Mylar									1
Stainless Steel									2

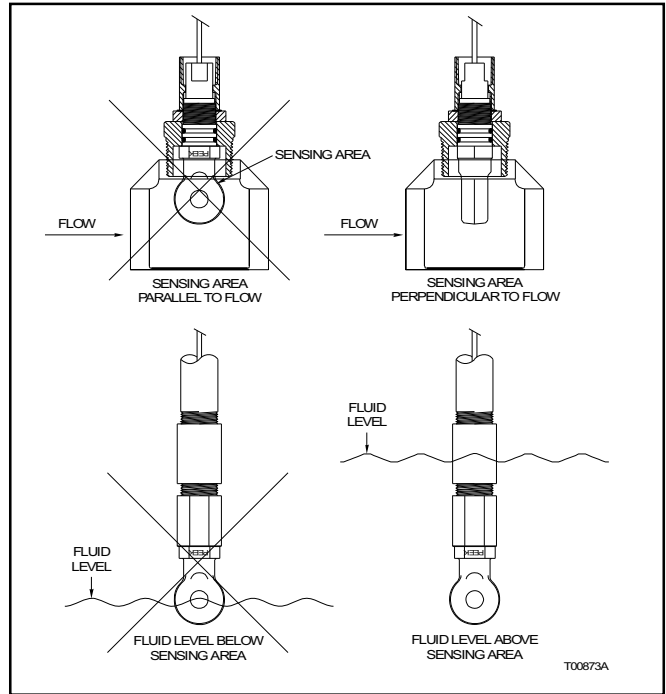
**Notes for TB404 Toroidal Conductivity Sensor:**

1. Pt 1000 Temperature Compensator is required for ABB TB8 Series Instrumentation
3. A "4" must be used for O-ring material if hot tap hardware & compression fittings are ordered & Kalrez O-rings are desired.
5. An insertion length must be specified for all sensors having an L1, L2, L3, or L4 designation. Type of material designated must match material in "hardware" section.
6. 1-1/2" full port, 316 Stainless Steel ball valves are available from the factory, part number 4TB5205-0285 (see accessories) 1-1/2" full port ball valve is minimum acceptable size.
7. Interconnecting cable, sensor to conductivity instrument, part number 4TB3004-0008 Cable Grips for J-Box, 4TB9515-0244, may be ordered separately

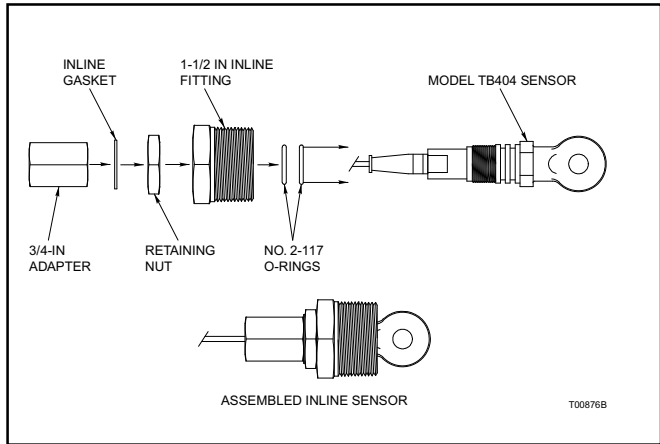




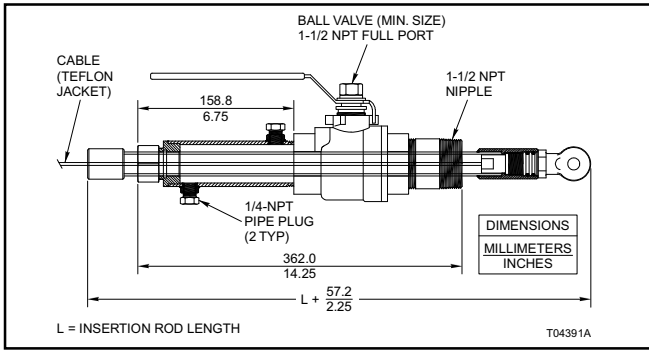
**Figure 8.** Model TB404 Sensor with Submersion Assembly



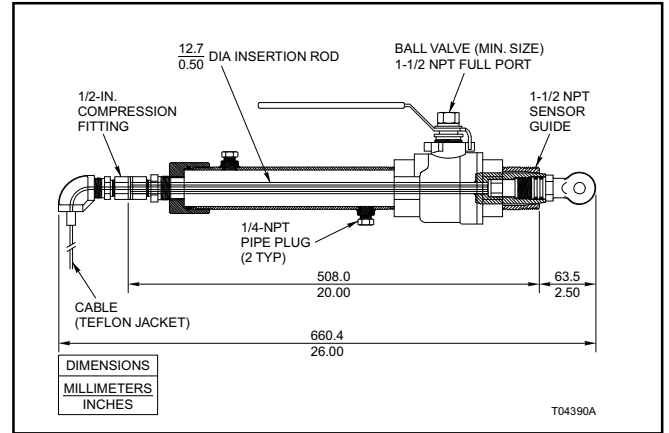
**Figure 10.** Installation



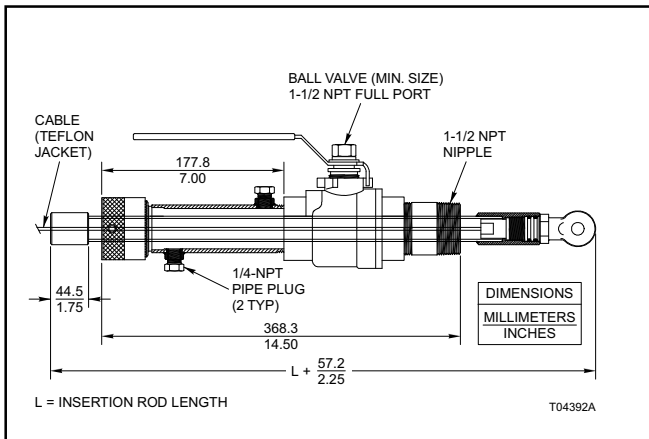
**Figure 9.** Model TB404 Sensor with Inline Flow Assembly



**Figure 11.** Hot Tap Sensor with Wrench Tight Compression Fitting



**Figure 13.** High Pressure Ball Valve Insertion Sensor Assembly



**Figure 12.** Hot Tap Sensor with Hand Tight Compression Fitting

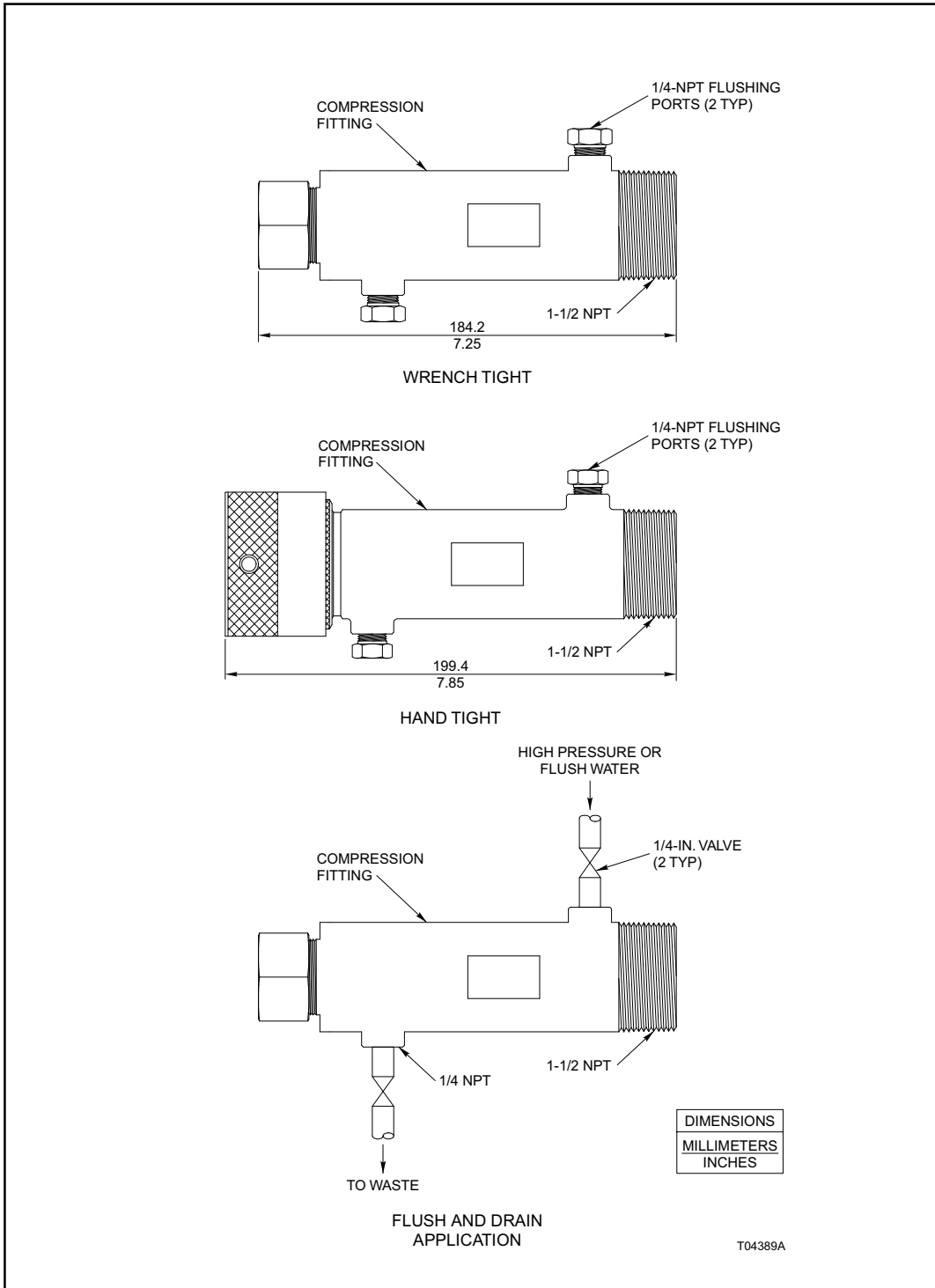








Figure 14. Flush and Drain and/or Pressurized Compression Hardware

## Notes



## Our offering:

	Actuators and Positioners		Analytical Instruments
	Device Management, Fieldbus and Wireless		Flow Measurement
	Force Measurement		Level Measurement
	Natural Gas Measurement		Pressure Measurement
	Recorders and Controllers		Temperature Measurement

## HMI – Automação e Instrumentação, Lda.

Rua dos 5 Caminhos, nº 570  
4780-382 Santo Tirso  
PORTUGAL

Tel. +351 252 850 501  
Fax. +351 300 013 487

Web: [www.hmi.pt](http://www.hmi.pt)

Email: [hmi@hmi.pt](mailto:hmi@hmi.pt)



# Contact us

## **ABB Inc.**

### **Process Automation**

843 N Jefferson Street

PO Box 831

Lewisburg 24901-9509

USA

Tel: +1 800 HELP 365 (435 7365)

Fax: +1 304 647 1862

## **ABB Limited**

### **Process Automation**

Oldends Lane

Stonehouse

Gloucestershire GL10 3TA

UK

Tel: +44 1453 826 661

Fax: +44 1453 829 671

## **ABB Engineering (Shanghai) Ltd.**

### **Process Automation**

No. 5, Lane 369, Chuangye Road

201319, Shanghai,

P.R. China

Phone: +86 (0) 21 6105 6666

Fax: +86 (0) 21 6105 6992

Mail: china.instrumentation@cn.abb.com

[www.abb.com](http://www.abb.com)

## Note

We reserve the right to make technical changes or modify the contents of this document without prior notice. With regard to purchase orders, the agreed particulars shall prevail. ABB does not accept any responsibility whatsoever for potential errors or possible lack of information in this document.

We reserve all rights in this document and in the subject matter and illustrations contained therein. Any reproduction, disclosure to third parties or utilization of its contents – in whole or in parts – is forbidden without prior written consent of ABB.

Copyright© 2013 ABB

All rights reserved

3KXA111402R1001