



hmi

high-accuracy
measurement
instruments

FICHA TÉCNICA DE PRODUTO

PRODUCT DATASHEET

HMI – Automação e Instrumentação, Lda.

Travessa da Indústria, nº 111
4780-573 Santo Tirso
PORTUGAL

Tel. +351 252 850 501
Fax. +351 300 013 487

Web: www.hmi.pt

Email: hmi@hmi.pt

ABB MEASUREMENT & ANALYTICS | DATA SHEET

TB2CS

2-electrode conductivity sensor

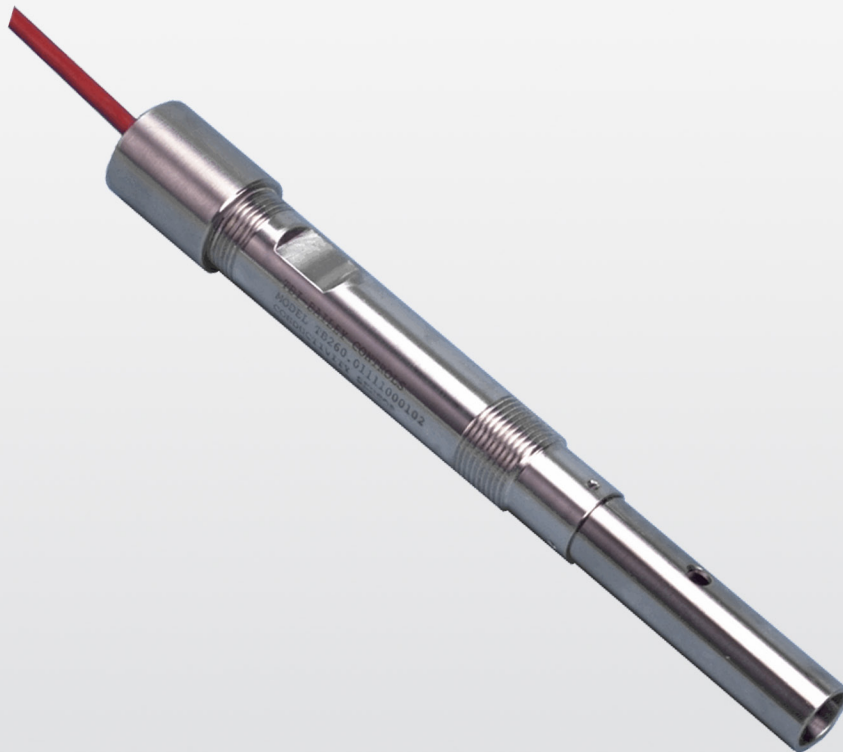

Measurement made easy

Superior accuracy in low level conductivity measurement ranges

Measurement range from 0 to 199.9 $\mu\text{S}/\text{cm}$ and 0 to 19.99 mS/cm

Resolution to 0.001 $\mu\text{S}/\text{cm}$ in lowest range

Corrosion resistant 316 stainless steel measurement electrodes

No calibration required

Rugged design

- sensor mounts directly into process line

NEMA 4X cast aluminum junction box

- provides easy access to process wiring

High pressure and temperature ratings

TB2 two-electrode conductivity sensors

The rugged, industrial grade TB2 two-electrode conductivity sensor installs directly into the process line or ABB flow cell. The sensor design allows for cell constants of 0.01, 0.10 and 1.00 and a maximum compensated measurement range of zero to 19.99 millisiemens per centimeter. Mounting configurations include in-line, submersible, hot tap and flow-through. A unique flow cell is available for flow-through installations. Polyether ether ketone (PEEK) insulator tip material and 316 stainless steel measurement electrodes provide corrosion resistance in all low to medium conductivity measurement applications.

The fixed cell constant makes the TB2 sensors essentially calibrated upon installation and thus especially well suited for low conductivity measurements. The sensor has an integral temperature compensation element and measurement electrodes that have not been sandblasted or altered in any way. These features guarantee the sensors as easy to install, reliable and accurate for all industrial conductivity measurement needs.

Choosing the correct conductivity sensor

ABB manufactures three types of conductivity sensors: two-electrode, four-electrode and toroidal conductivity. Each sensor type has its own unique advantages. Two-electrode conductivity sensors are only available for low to medium conductivity ranges, with a maximum conductivity of 19.99 millisiemens per centimeter. Four-electrode and toroidal conductivity sensors are generally used in medium to high conductivity measurement ranges, applications with aggressive chemicals and applications that tend to coat or scale the measurement electrode. Refer to the appropriate product specification for more information on four-electrode and toroidal conductivity sensors.

- 1 Determine the range of conductivity measurement desired. Although they can be used at higher conductivity ranges, the optimum for two-electrode sensors is zero to 199.9 microsiemens per centimeter or the 0.01 cell constant. Table 1 lists the cell constants for two-electrode conductivity sensors and their respective ranges.

Cell constant	Conductivity range
0.01	0 to 1.999 $\mu\text{S}/\text{cm}$, 0 to 19.99 $\mu\text{S}/\text{cm}$, 0 to 199.9 $\mu\text{S}/\text{cm}$
0.10	0 to 19.99 $\mu\text{S}/\text{cm}$, 0 to 199.9 $\mu\text{S}/\text{cm}$, 0 to 1,999 $\mu\text{S}/\text{cm}$
1.00	0 to 199.9 $\mu\text{S}/\text{cm}$, 0 to 1,999 $\mu\text{S}/\text{cm}$, 0 to 19.99 mS/cm

Table 1 Conductivity ranges

- 2 Check that the process chemistry is compatible with 316 stainless steel measurement electrodes. This material is compatible with most process fluids except for some acids. ABB manufactures four-electrode conductivity sensors with special measurement electrode materials and toroidal conductivity sensors for processes that attack 316 stainless steel.
- 3 Establish the maximum process temperature and pressure.
- 4 Determine the sensor installation method: in-line threaded, in-line sanitary fitting, in-line ball valve insertion, submersible, or flow cell. Table 2 lists the sensors compatible with each method.
- 5 Select either a Pt 100 or Pt 1000 integral temperature compensation element. The type TB82TE two-electrode conductivity transmitter and type TB84TE two-electrode conductivity analyzer both accept either temperature compensation element type. The AX41 accepts a Pt 1000 temperature element.
- 6 Determine the length of cable needed to reach from the sensor to the instrument. Order the cable as either integral to the sensor or by using the junction box and extension cable as separate items.
- 7 Use the information from Steps 1 through 6 and the ordering guides to create a sensor model number. One choice must be made in all positions of the ordering guide.

Installation methods

Table 2 lists the sensors and their applicable installation methods. Complete information about each sensor is located in the appropriate specification, dimension and ordering information sections.

Sensor	Installation methods
TB254	In-line, twistlock insertion, threaded Ryton® receptacle, submersible
TB26	Inline, direct insertion (tee), hot tap ball valve insertion, hot tap threaded compression fitting, submersible
TB264	Inline, 25 mm (sterilizable), flow cell, submersible
TB27	Inline high pressure hot tap ball valve insertion

Table 2 Installation methods

... TB2 two-electrode conductivity sensors

Flow cells

The flow cell (Figure 1) is available for both conductivity and pH sensors. It is designed for use with the TB264 two-electrode conductivity sensors, the TB464 four-electrode conductivity sensors and the TB561 and TBX561 pH/ORP sensors. Multiple inlet and outlet ports provide flexibility with installation, calibration and mounting configurations. The sensor can be inserted and removed from the flow cell quickly and easily without disconnecting the sensor from the instrument or junction box. Refer to Table 3 for the flow cell kit part numbers.

Dimensions in mm (in)

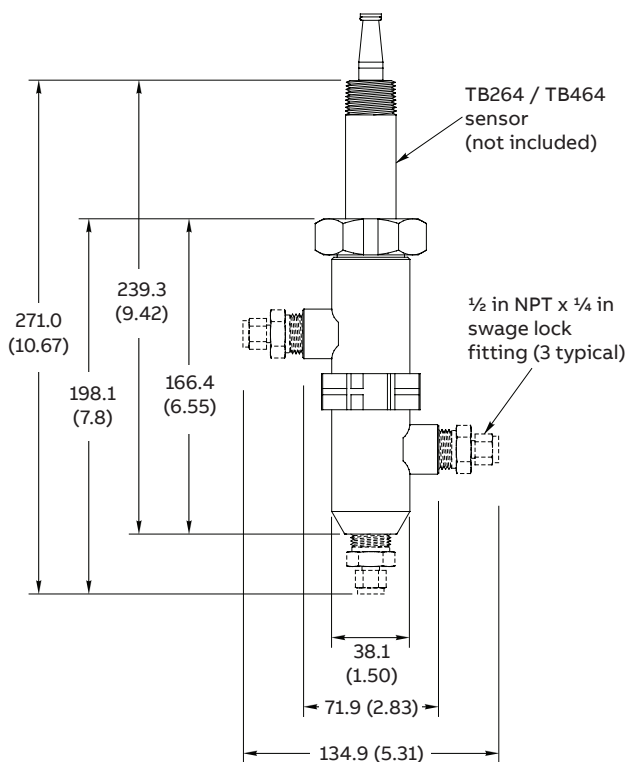

Figure 1 Flow cell dimensions

Note. Dashed lines represent dimensions of flow cell kit with swage lock fittings.

Part number	Description
4TB9515-0190	Flow cell kit with swage lock fittings
4TB9515-0223	Flow cell kit without swage lock fittings

Table 3 Flow cell kits

Junction box

The junction box (Figure 2) is a standard item, selected from the ordering guide, typically used with an extension cable for direct connection to ABB transmitters and analyzers.

Dimensions in mm (in)

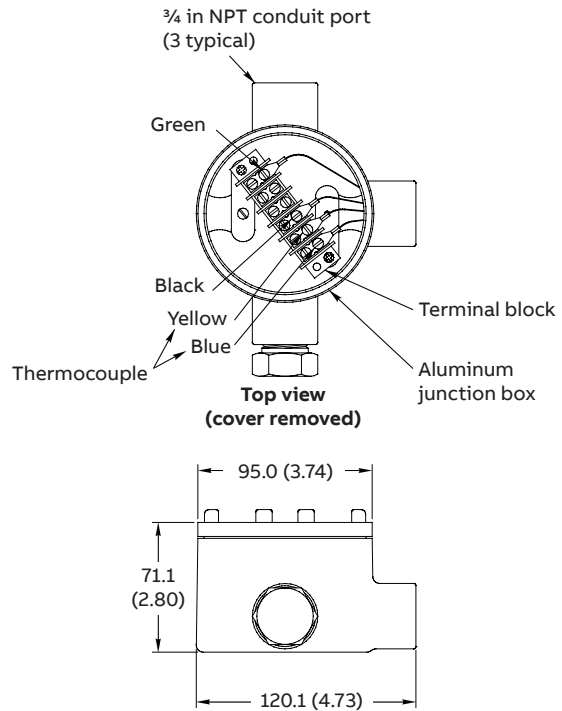

Figure 2 Junction box

Temperature compensation

The effect of temperature on conductivity is significant. Temperature must be compensated to a reference temperature, typically 25 °C (77 °F), for accurate measurements. All of the conductivity sensors covered in this specification have either a Pt 100 or Pt 1000 integral temperature compensation element. These are located deep enough inside the tip of the sensor to ensure a fast and accurate response to temperature changes.

The integral temperature compensation elements are compatible with both the TB82TE transmitter and TB84TE analyzer. These instruments are capable of several different modes of temperature compensation: manual, automatic for potassium chloride (KCl), user-entered coefficient in percent per degree Celsius and three types for pure water (trace acid, trace base and neutral salt). Other choices are available to match various acid and base solutions.

TB254 sensor

TB254 sensors (Figure 3) can be installed either in-line or used for submersible applications. In-line applications consist of 1 in NPT receptacles where the sensor is either inserted and twisted 90 degrees or inserted and held in place by a cap nut. Easy, yet flexible installation makes this sensor ideal for general use conductivity measurements



Figure 3 TB254 sensor

Specification

Applications (typical)

- Cooling towers
- Packaged water systems
- Exchange columns
- Heat exchangers
- All other low- to medium-range conductivity measurements

Special features

Twist-lock and Ryton threaded receptacle make sensor access quick and easy

Materials

Sensor body:	Ryton
Measurement electrode:	316 stainless steel
Insulator:	PEEK
O-rings (internal):	Viton
O-rings (external):	Buna-N
1 in NPT twist-lock receptacle:	316 stainless steel
Threaded receptacle:	Ryton

Ratings (max.)

Temperature:	100 °C (212 °F)
Pressure:	690 kPa at 100 °C (100 psi at 212 °F)

Sensor mounting

In-line:	1 in NPT receptacles
Submersion:	$\frac{3}{4}$ in NPT for support pipe

...TB254 sensor

Dimensions

Dimensions in mm (in)

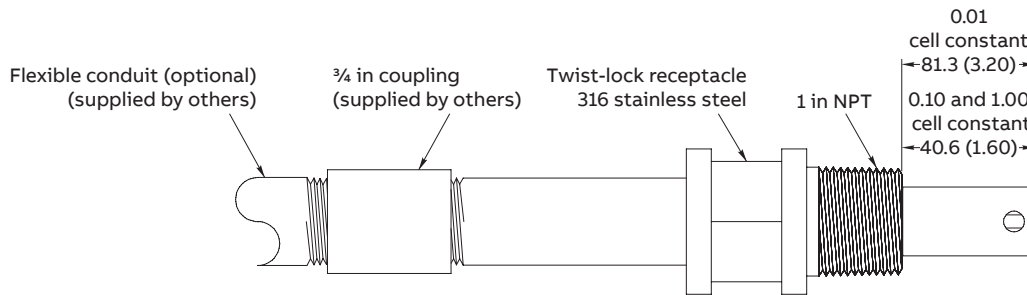
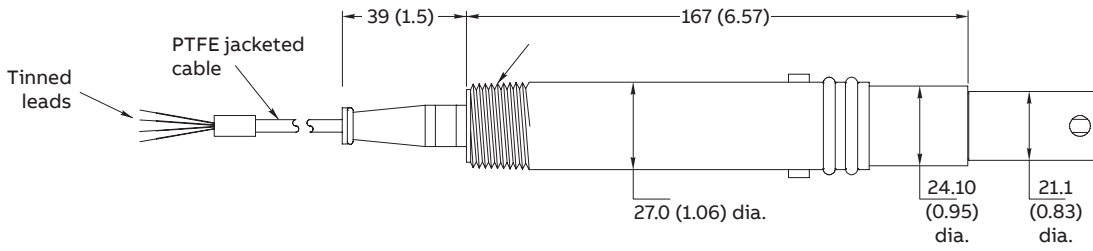

In-line applications (twist-lock)

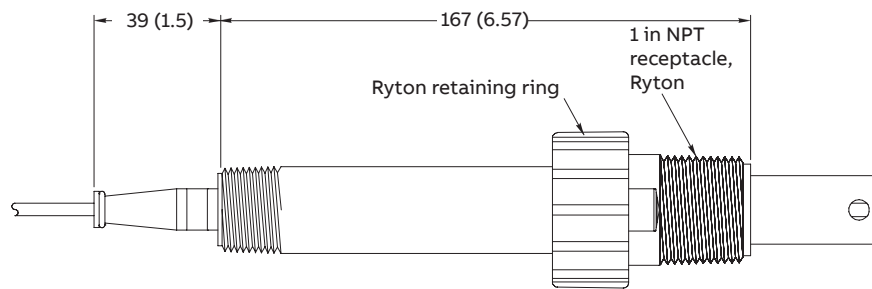
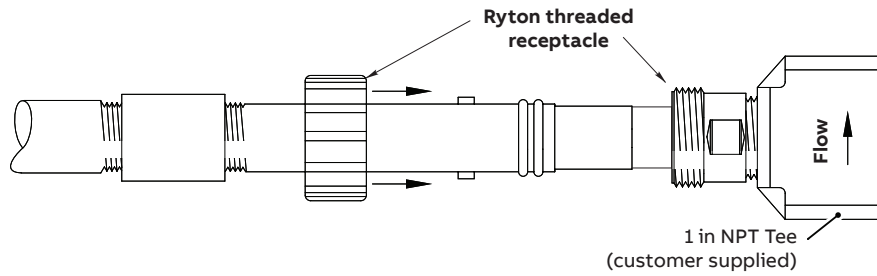

In-line applications (threaded)

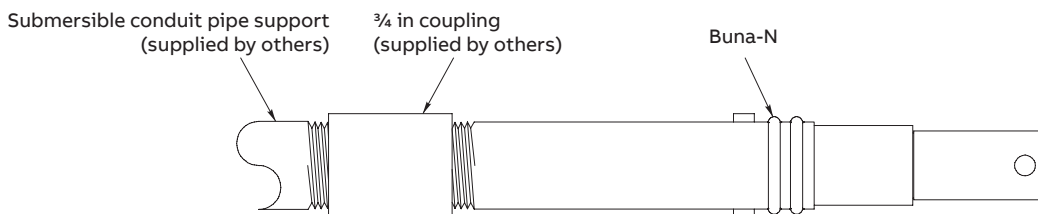

Submersible applications

Note. Minimum pipe diameter (Schedule 80): 0.01 cell constant: $\frac{101.6}{4.0}$, 0.10 and 1.00 cell constant: $\frac{63.5}{2.50}$.

Ordering information

Ryton body, PEEK tip conductivity sensor	TB254	XXXX	X	X	X	0	X	X	X
Cell constant									
0.01		0.01							
0.10		0.10							
1.00		1.00							
Integral temperature compensation element									
Pt1000			1						
O-ring material									
Standard (ethylene propylene)				1					
Measurement electrode material									
316 stainless steel					1				
Reserved									
For future use						0			
Mounting accessories									
None								0	
Stainless receptacle								2	
Ryton threaded receptacle								3	
Cable length in m (ft)									
No cable, junction box included									0
1.5 (5)									1
3.0 (10)									2
4.6 (15)									3
6.1 (20)									4
9.1 (30)									5
7.6 (25)									6
10.7 (35)									7
12.2 (40)									8
13.7 (45)									9
15.2 (50)									A
22.9 (75)									B
30.5 (100)									C
Insulator tip material									
PEEK									2

Stainless steel sensor tag: 4TB5003-0003
 Mylar sensor tag: 4TB5003-0002
 Interconnecting cable from sensor to analyzer: 4TB3004-0008 (specify length when ordering)

TB26 sensor

TB26 sensors (Figure 4) are easily installed into process lines and vessels via the integral $\frac{3}{4}$ in NPT threads, submersed directly into lines and vessels via the $\frac{1}{2}$ in NPT backthreads, or inserted into a process line or vessel through a ball valve.

The ball valve provides isolation between the sensor and the process, allowing sensor insertion and removal while the line or vessel is full. This is accomplished by using a $1\frac{1}{2}$ in standard ball valve.

A compression fitting with flushing ports enables the operator to wash away any left-over process fluid after removing the sensor. The flushing ports also provide a quick and easy place to take a grab sample for calibration.

Variable sensor lengths are available for all TB26 sensor styles. The hot tap sensor can be used with the compression fitting and without the ball valve to provide even greater installation flexibility.

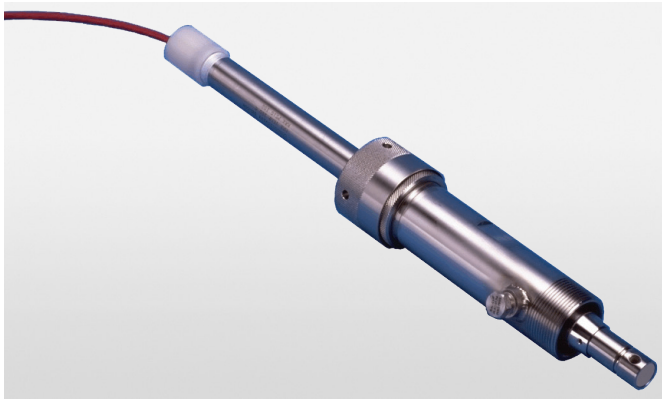

Figure 4 TB26 sensor with block and drain compression fitting

Specification

Applications (typical)

- Pure water
- Low conductivity
- Boiler measurements
- Cooling towers
- Condensate
- Exchange columns
- Heat exchangers
- All other low- to medium-range conductivity measurements

Special features

- Interchangeable and replaceable sensor tips
- Antiblowout lip on hot tap versions is machined into sensor body providing safety without restraining lanyards that are often left unused

Materials ¹

Sensor body and measurement electrode:	316 stainless steel
Insulator:	PEEK
O-rings (internal):	Viton
O-rings (external):	Ethylene propylene
Packing gland ferrule:	PTFE

Ratings (max.)

Insertion / submersion:	
Temperature	200 °C (392 °F)
Pressure	1551 kPa at 200 °C (225 psi at 392 °F)
Hot tap:	
Temperature	200 °C (392 °F)
Pressure	690 kPa at 200 °C (100 psi at 392 °F)

Sensor mounting

In-line:	$\frac{3}{4}$ in NPT process connection
Hot tap:	$1\frac{1}{2}$ in NPT extraction housing
Submersion:	Rear $\frac{1}{2}$ in NPT for support pipe

¹ Contact ABB for other available materials

Dimensions

Dimensions in mm (in)

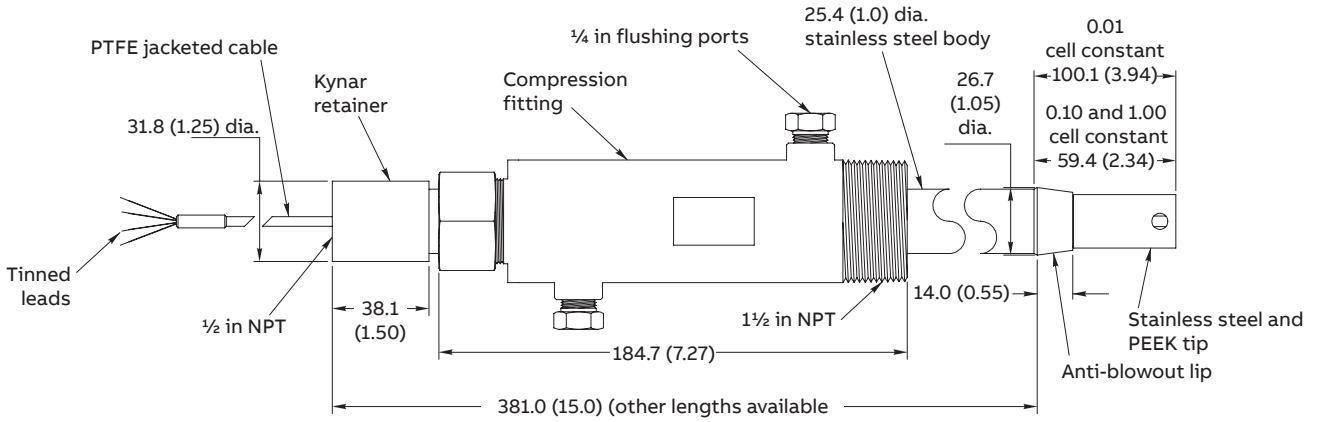

Hot tap with wrench-tight flush and drain compression fitting

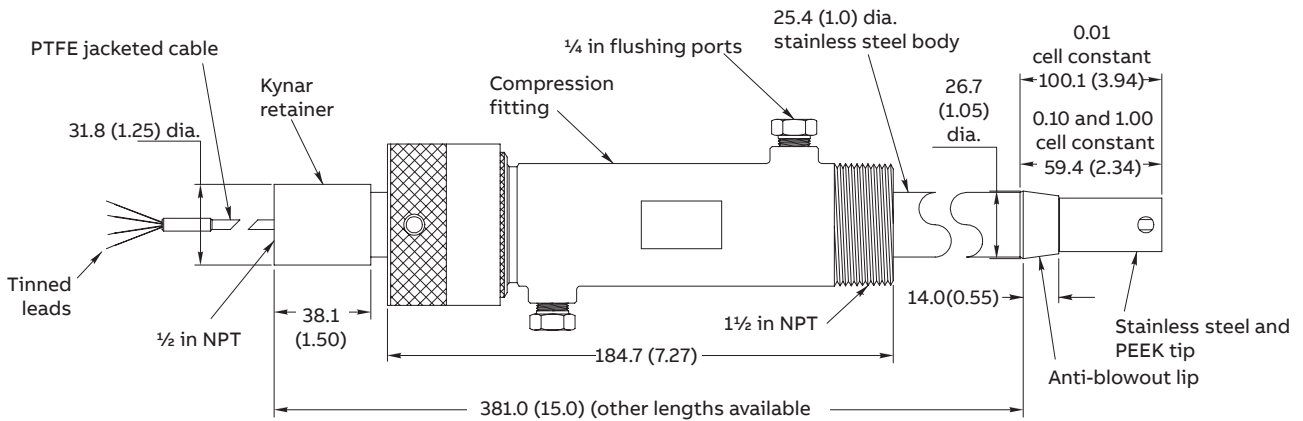

Hot tap with hand-tight flush and drain compression fitting

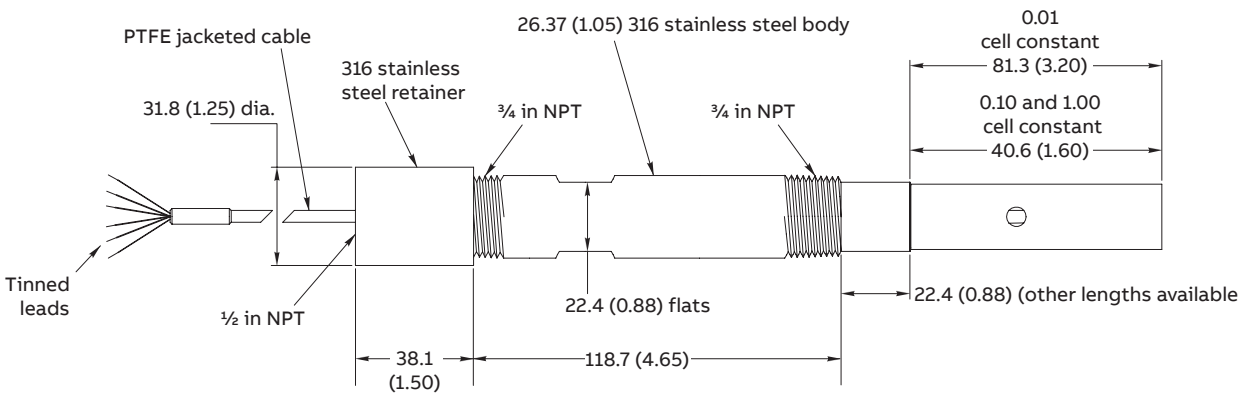

Tee-mounting or submersion

...TB26 sensor

Ordering information

Insertion / submersion / hot tap conductivity sensor	TB26	XXXX	X	X	X	0	X	X	X	X	X
Cell constant											
0.01		0.01									
0.10		0.10									
1.00		1.00									
Integral temperature compensation element											
Pt1000			1								
O-ring material											
Standard (ethylene propylene)				1							
Measurement electrode material											
316 stainless steel					1						
Reserved											
For future use						0					
Style											
In-line / submersible, ¾ NPT							0				
Hot tap, no hardware, 406 mm (16 in) length							1				
Hot tap, no hardware, 610 mm (24 in) length							4				
Hot tap, no hardware, 762 mm (30 in) length							5				
Hot tap, no hardware, 914 mm (36 in) length							6				
Mounting accessories											
None								0			
Compression hardware, hand tight (hot tap style only)								1			
Compression hardware, wrench tight (hot tap style only)								2			
Cable length in m (ft)											
No cable, junction box included									0		
1.5 (5)									1		
3.0 (10)									2		
4.6 (15)									3		
6.1 (20)									4		
7.6 (25)									5		
9.1 (30)									6		
10.7 (35)									7		
12.2 (40)									8		
13.7 (45)									9		
15.2 (50)									A		
22.9 (75)									B		
30.5 (100)									C		
Insertion length in mm (in)											
0.01 cell constant											
105 (4.1) – standard length / hot tap										0	
125 (4.9) – not hot tap style										1	
150 (5.9) – not hot tap style										3	
175 (6.9) – not hot tap style										5	
200 (7.9) – not hot tap style										7	
226 (8.9) – not hot tap style										9	
250 (9.9) – not hot tap style										B	
0.1 / 1.0 cell constants											
65 (2.5) – standard length / hot tap										0	
85 (3.3) – not hot tap style										1	
110 (4.3) – not hot tap style										3	
135 (5.3) – not hot tap style										5	
160 (6.3) – not hot tap style										7	
185 (7.3) – not hot tap style										9	
210 (8.3) – not hot tap style										B	
Insulator tip material											
PEEK											2

Stainless steel sensor tag:

4TB5003-0003

Mylar sensor tag:

4TB5003-0002

Interconnecting cable from sensor to analyzer:

4TB3004-0008 (specify length when ordering)

TB264 sensor

TB264 sensors (Figure 5) can be installed either inline via a 25 mm (0.98 in) style fitting or used for flow cell applications. Inline applications consist of using an existing 25 mm (0.98 in) port or purchasing a bushing and holder nut. This sensor quickly and easily installs into the flow cell.

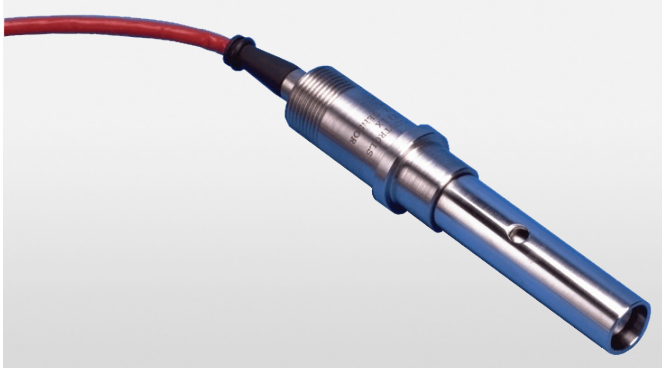

Figure 5 TB264 sensor

Specification

Applications (typical)

- Cooling towers
- Packaged water systems
- Exchange columns
- Heat exchangers
- All other low- to medium-range conductivity measurements

Special features

- Easy installation into either flow cell or any available 25 mm (0.98 in) port
- Flexible insertion depth

Materials

Sensor body and measurement electrode:	316 stainless steel
Insulator:	PEEK
O-rings (internal):	Viton
O-rings (external):	Ethylene propylene

Ratings (max.)

Temperature:	200 °C (392 °F)
Pressure:	1379 kPa at 200 °C (200 psi at 392 °F)

Sensor mounting

In-line:	25 mm (0.98 in) process connection
Flow cell:	ABB flowcell – see Figure 1 on page 4 for connection types
Safe-T-Clean valve:	ABB TB18 – refer to TB18 data sheet (DS/TB18-EN) for connection types

...TB264 sensor

Dimensions

Dimensions in mm (in)

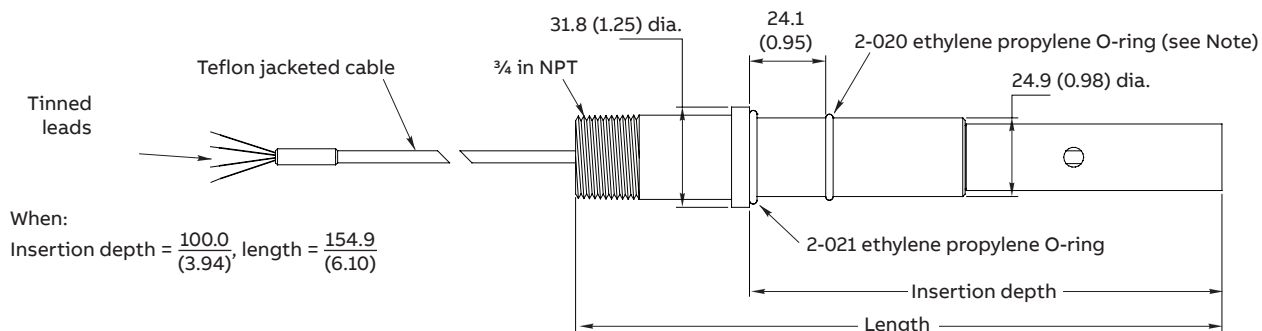

Note. 2-020 ethylene propylene O-ring location is not applicable to 100 mm (3.94 in) body length for 0.01 cell constant.

Ordering information

25 mm (0.98 in) fitting, sanitary conductivity sensor	TB264	XXXX	X	X	X	0	XXX	X	X
Cell constant									
0.01 ¹		0.01							
0.10		0.10							
1.00		1.00							
Integral temperature compensation element									
Pt1000			1						
O-ring material									
Standard (ethylene propylene)				1					
Measurement electrode material									
316 stainless steel					1				
Reserved									
For future use						0			
Body style									
100 mm (3.93 in) insertion depth ²							100		
Cable length in m (ft)									
No cable, junction box included									0
1.5 (5)									1
3.0 (10)									2
4.6 (15)									3
6.1 (20)									4
7.6 (25)									5
9.1 (30)									6
10.7 (35)									7
12.2 (40)									8
13.7 (45)									9
15.2 (50)									A
22.9 (75)									B
30.5 (100)									C
Insulator tip material									
PEEK									2

Stainless steel sensor tag: 4TB5003-0003
 Mylar sensor tag: 4TB5003-0002
 Interconnecting cable from sensor to analyzer: 4TB3004-0008 (specify length when ordering)

¹ Not compatible with TB18 Safe-T-Clean valve

² Required for use with flowcells part nos. 4TB9515-0223 and 4TB9515-0190 or TB18 Safe-T-Clean valve

TB27 sensor

TB27 sensors (Figure 6) can be inserted or removed from process lines or vessels via a ball valve without disturbing the process. The TB27 sensor is designed for applications that exceed standard hot tap sensor pressure ratings and for operator safety. An extraction housing isolates the operator from the process fluid.

This housing has 6 mm (¼ in) ports for flushing, draining, pressurizing or depressurizing the chamber. Ruggedly constructed of 316 stainless steel, these sensors withstand the most demanding processes and measurement requirements.

For safety reasons, it is recommended that the operating pressure be reduced below 690 kPa (100 psi) during insertion and retraction of the sensor assembly.



Figure 6 TB27 sensor

Specification

Applications (typical)

- Boil condensate
- Sealed vessel monitoring
- Toxic chemical monitoring
- Heat exchangers
- All other low- to medium-range conductivity measurements that have higher pressures or where operator safety is a concern

Special features

- Interchangeable and replaceable sensor tips
- High pressure capability
- Purgeable sensor extraction housing

Materials¹

Sensor body, measurement electrode, valve, extraction housing, insertion assembly and compression fitting:	316 stainless steel
Insulator:	PEEK
O-rings (internal):	Viton
O-rings (external):	Ethylene propylene
Compression fitting ferrule	Kynar® (PVDF)

Ratings (max.)

Temperature:	200 °C (392 °F)
Pressure:	2068 kPa at 200 °C (300 psi at 392 °F)

Sensor mounting

Hot tap:	1¼ in NPT
----------	-----------

Hot tap

¹ Contact ABB for other available materials

² Safe operating pressure limits are recommended during retraction / insertion; maximum 690 kPa (100 psi).

...TB27 sensor

Dimensions

Dimensions in mm (in)

All dimensions are nominal

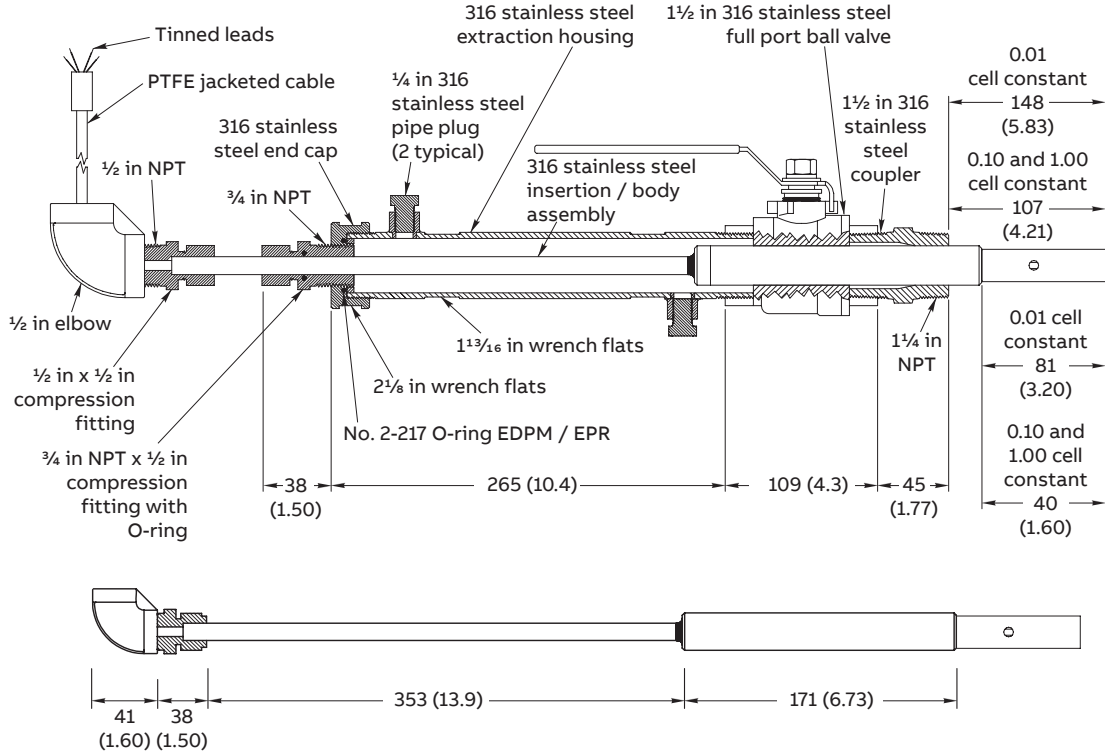

Ordering information

High pressure, hot tap conductivity sensor	TB27	XXXX	X	X	X	0	X	X	X
Cell constant									
0.01		0.01							
0.10		0.10							
1.00		1.00							
Integral temperature compensation element									
Pt1000			1						
O-ring material									
Standard (ethylene propylene)				1					
Measurement electrode material									
316 stainless steel					1				
Reserved									
For future use						0			
Mounting accessories									
Complete assembly, includes ball valve and enclosure, 1¼ in NPT process connections							0		
Basic sensor, without ball valve, requires 1½ in NPT ball valve							6		
Basic sensor, without ball valve or enclosure, replacement probe							7		
Cable length in m (ft)									
No cable, junction box included									0
1.5 (5)									1
3.0 (10)									2
4.6 (15)									3
6.1 (20)									4
7.6 (25)									5
9.1 (30)									6
10.7 (35)									7
12.2 (40)									8
13.7 (45)									9
15.2 (50)									A
22.9 (75)									B
30.5 (100)									C
Insulator tip material									
PEEK									2

Stainless steel sensor tag: 4TB5003-0003
 Mylar sensor tag: 4TB5003-0002
 Interconnecting cable from sensor to analyzer: 4TB3004-0008 (specify length when ordering)

Acknowledgements

- Ryton is a registered trademark of the companies that comprise the Solvay Group or their respective owners.
- Kynar is a registered trademark of Arkema Inc.



ABB Limited

Measurement & Analytics

Oldends Lane, Stonehouse
Gloucestershire, GL10 3TA
UK

Tel: +44 (0)1453 826 661

Fax: +44 (0)1453 829 671

ABB Inc.

Measurement & Analytics

125 E. County Line Road
Warminster, PA 18974

USA

Tel: +1 215 674 6000

Fax: +1 215 674 7183











abb.com/measurement

We reserve the right to make technical changes or modify the contents of this document without prior notice. With regard to purchase orders, the agreed particulars shall prevail. ABB does not accept any responsibility whatsoever for potential errors or possible lack of information in this document.

We reserve all rights in this document and in the subject matter and illustrations contained therein. Any reproduction, disclosure to third parties or utilization of its contents – in whole or in parts – is forbidden without prior written consent of ABB.



Our offering:

	Actuators and Positioners		Analytical Instruments
	Device Management, Fieldbus and Wireless		Flow Measurement
	Force Measurement		Level Measurement
	Natural Gas Measurement		Pressure Measurement
	Recorders and Controllers		Temperature Measurement

HMI – Automação e Instrumentação, Lda.

Travessa da Indústria, nº 111
4780-573 Santo Tirso
PORTUGAL

Tel. +351 252 850 501
Fax. +351 300 013 487

Web: www.hmi.pt

Email: hmi@hmi.pt