



FICHA TÉCNICA DE PRODUTO

PRODUCT DATASHEET

HMI – Automação e Instrumentação, Lda.

Travessa da Indústria, nº 111
4780-573 Santo Tirso
PORTUGAL

Tel. +351 252 850 501
Fax. +351 300 013 487

Web: www.hmi.pt

Email: hmi@hmi.pt

Model NAA

Differential pressure transmitter

Deltapi N Series
A complete range of
pneumatic pressure transmitters

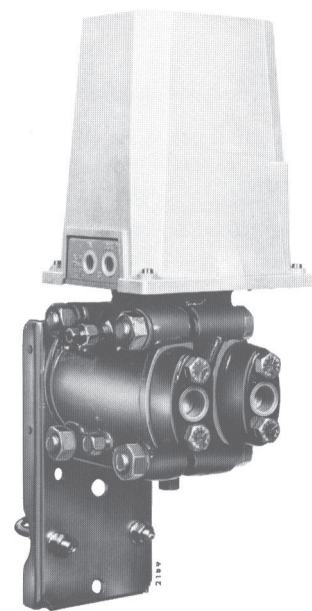

Introduction

The blind type differential pressure transmitter mod. NAA is used to measure and convert a differential pressure value into a proportional pneumatic signal.

DESCRIPTION

The instrument works on the force-balance principle and consists of two main units.

The measuring unit which detects the differential pressure variation and consists of two forged bodies and a measuring capsule.

The capsule is available in two versions: 2in or 3in diameter diaphragms, filled with a special liquid, which can withstand the maximum rated static pressure on either side without damaging itself.

The transmission unit converts the differential force applied to the measuring element into a proportional output pneumatic signal.

The output pressure, generated by a flapper nozzle relay, feeds the feedback bellows with a rising pressure until the bellows force balances that of the measuring element.

Span value continuously adjustable by an internal micrometric screw.

Zero value adjustable by an external screw.

Mounting in a vertical position on 2in diameter pipe by a special bracket.

OPTIONAL EXTRA FEATURES

Special feedback bellows allow to reduce the standard calibration span to a lower value (see table)

A zero elevation or suppression device allows to set as a zero of the transmitter a measured variable value different from zero.

The sum of the zero suppression value (S) plus the calibrated span cannot exceed the upper range limit (M) suitable for the diaphragm capsule : $S + \text{span} \leq M$ (see table).

Air filter regulator can be directly mounted on the transmitter, with or without pressure gauge, and connected with piping and fittings either in stainless steel or copper.

Special versions of air filter regulator and gauges, in stainless steel, are available on request. **Manifold.** The transmitter can be supplied with a 3-valve manifold block integrally mounted to simplify maintenance and calibration procedures.

Oxygen measurements, special degreasing and final test operations can be required on the oxygen measuring transmitter.

SPECIFICATIONS

The data were obtained from laboratory tests on standard instruments with: carbon steel or AISI 316L bodies; AISI 316L measuring element with silicone oil filling; gasket: PTFE; calibration span: 18 kPa - 180 mbar (for 3in diaphragm), 70 kPa - 700 mbar (for 2in diaphragm)

MEASURING CAPSULE (DIAPHRAGM DIA.)	SPAN LIMITS min. and max.	RANGE LIMITS (lower and upper)	MAXIMUM ZERO SUPPRESSION (S)	MAXIMUM ZERO ELEVATION	STATIC PRESSURE LIMITS Full vacuum and
2 in	30 and 170 kPa 300 and 1700 mbar	-170 and + 170 kPa -1700 and +1700 mbar	140 kPa 1400 mbar	170 kPa 1700 mbar	10 MPa (*) 100 bar (*)
3 in	5 and 52 kPa 50 and 520 mbar	-52 and +52 kPa -520 and +520 mbar	47 kPa 470 mbar	52 kPa 520 mbar	
3 in with special feedback bellows	2.5 and 7.5 kPa 25 and 75 mbar	-52 and +52 kPa -520 and +520 mbar	49.5 kPa 495 mbar	52 kPa 520 mbar	

(*) Equal to Maximum Working pressure as well as Overrange Limit (on either side).

Air supply

nom. 140 kPa (1.4 bar, 20 psi); min. 125 kPa (1.25 bar, 18 psi); max. 175 kPa (1.75 bar, 25 psi)

Output signal

20 to 100 kPa, 0.2 to 1 bar, 3 to 15 psi or 0.2 to 1 kg/cm²

Static air consumption

350 NI/h

Maximum output flow

- with rising output pressure: 30 NI/min.
- with falling output pressure: 40 NI/min.

Accuracy

± 0.5% F.S.D. (typical)

Thermal drift (for ambient temperature variation between - 20° C and + 65° C)

- with 2in diaphragm
 - span 30 to 80 kPa (300 to 800 mbar): 0.5%/10°C
 - span 80 to 170 kPa (800 to 1700 mbar): 0.2%/10°C
- with 3in diaphragm
 - span 5 to 10 kPa (50 to 100 mbar): 0.6%/10°C
 - span 10 to 52 kPa (100 to 520 mbar): 0.2%/10°C

Static pressure effect :

for variation of 3.3 MPa (33 bar): ≤ ± 0.25%

Maximum displacement

- with 2in diaphragm: 1 cm³
- with 3in diaphragm: 1.5 cm³

Degree of protection in accordance with IEC 529

IP55

Ambient temperature limits

-40 and + 120°C

Bodies material

Carbon steel, AISI 316 L

Body bolts and nuts material

High tensile carbon steel;
AISI 316 Class A4-70 per ISO 3506;
AISI 316 Class A4-50 (*) per ISO 3506, in compliance with NACE MR0175
high tensile stainless steel, in compliance with NACE MR0175

(*) Maximum static pressure reduced to 7.5 MPa (75 bar)

Cover material

thermoplastic resin

Diaphragm material

AISI 316 L, Monel (*), Hastelloy C

(*) Maximum overrange pressure reduced to 5 MPa (50 bar)

Gaskets material

PTFE, Viton

Capsule filling

Silicone oil, Perfluorinated polyethers (Galden) (*)

(*) When used for oxygen measurements the operating temperature limits are -20°C and + 40°C.

Surface protections

- carbon steel body and flange: zinc plating and chrome passivation
- AISI 316 body and flange: no protection

Process connections (see figure ref. D and E)

- on flanges: 1/2 in NPT-F
- on adapters: 1/4 in NPT-F
- center distance: 54 mm.

Pneumatic connections

- Air supply (in figure ref. A): 1/4 in NPT-F
- Output (in figure ref. B): 1/4 in NPT-F

Pressure gauge

Brass with stainless steel case (all stainless steel on request)
external diameter 51 mm; 0-200 kPa, 0-2 bar and 0-30 psi
indication on 82 mm/260° scale.

Air filter regulator

with copper or stainless steel piping, as specified.
Die cast aluminium alloy with light grey epoxy finish.

Net weight (maximum)

11 kg approx

Packing

expanded polythene box

ORDERING INFORMATION

Select one character or set of characters from each category and specify complete catalog number.

PRODUCT CODE

abc de fg hi j k lm



abc	BASE MODEL	Code
	Differential pressure transmitter	NAA

de	VERSION	
	Standard with body bolts and nuts in high tensile carbon steel	01
	As 01 with integrally mounted manifold (to be quoted separately)	07
	Standard with body bolts and nuts in AISI 316	11
	As 11 with integrally mounted manifold (to be quoted separately)	17
	Standard with body bolts and nuts in high tensile stainless steel	21
	As 21 with integrally mounted manifold (to be quoted separately)	27
	Standard with body bolts and nuts in AISI 316	51
	As 51 with integrally mounted manifold (to be quoted separately)	57
		Maximum operating pressure reduced to 7.5 MPa (1070 psi)

fg	BODY	
	Carbon steel	01
	AISI 316L	41

MEASURING ELEMENT						
hi	Diaphragm material	Core material	Capsule filling	Capsule diameter	Span limits kPa (inH₂O) - (Note 1)	
	AISI 316L	AISI 316L (Note 2)	Inert fill (**)	3 in	5 and 52 (20 and 208)	04
	AISI 316L	AISI 316L (Note 2)	Inert fill (**)	2 in	30 and 170 (120 and 682)	05
	AISI 316L	AISI 316L (Note 2)	Inert fill (**)	3 in	2.5 and 7.5 (10 and 30)	06
	Monel	Monel (*)	Silicone oil	3 in	5 and 52 (20 and 208)	21
	Monel	Monel (*)	Silicone oil	2 in	30 and 170 (120 and 682)	22
	Monel	Monel (*)	Silicone oil	3 in	2.5 and 7.5 (10 and 30)	23
	AISI 316L	AISI 316L (Note 2)	Silicone oil	3 in	5 and 52 (20 and 208)	41
	AISI 316L	AISI 316L (Note 2)	Silicone oil	2 in	30 and 170 (120 and 682)	42
	AISI 316L	AISI 316L (Note 2)	Silicone oil	3 in	2.5 and 7.5 (10 and 30)	43
	Hastelloy C	Hastelloy C	Silicone oil	3 in	5 and 52 (20 and 208)	51
	Hastelloy C	Hastelloy C	Silicone oil	2 in	30 and 170 (120 and 682)	52
	Hastelloy C	Hastelloy C	Silicone oil	3 in	2.5 and 7.5 (10 and 30)	53
	Hastelloy C	AISI 316L	Silicone oil	3 in	5 and 52 (20 and 208)	54
	Hastelloy C	AISI 316L	Silicone oil	2 in	30 and 170 (120 and 682)	55
	Hastelloy C	AISI 316L	Silicone oil	3 in	2.5 and 7.5 (10 and 30)	56

Note 1: Multiply by 10 the value in kPa (MPa) to obtain mbar (bar).

Note 2: Hastelloy C for some wetted parts.

(*) Maximum overrange 5 MPa (725 psi)

(**) Suitable for oxygen service (operating temperature limits reduced: -20°C to + 40°C; -4°F to 104°F)

j	GASKETS		Fulcrum diaphragm gasket	
	Flange gasket	Capsule gasket		
	Viton	Viton	Viton	4
	PTFE (*)	PTFE (*)	PTFE (*)	5

(*) Suitable for oxygen service.

k OUTPUT

3 to 15 psi	According to ANSI/ISA S 51.1-1979 standard terminology	1
3 to 15 psi with zero elevation device		2
3 to 15 psi with zero suppression device		3
0.2 to 1.0 kg/cm ²		4
0.2 to 1.0 kg/cm ² with zero elevation device		5
0.2 to 1.0 kg/cm ² with zero suppression device		6
20 to 100 kPa / 0.2 to 1 bar		7
20 to 100 kPa / 0.2 to 1 bar with zero elevation device		8
20 to 100 kPa / 0.2 to 1 bar with zero suppression device		9

EXTRAS

Im	Identification tag material	Piping material	Air filter regulator	Pressure gauge	
	Stainless Steel	--	--	--	02
	Stainless Steel	Stainless Steel	with	--	10
	Stainless Steel	Copper	with	--	11
	Stainless Steel	Stainless Steel	with	with	13
	Stainless Steel	Copper	with	with	14

Compliance to NACE class II bolting, according to specification MR0175, latest revision

MOUNTING DIMENSIONS

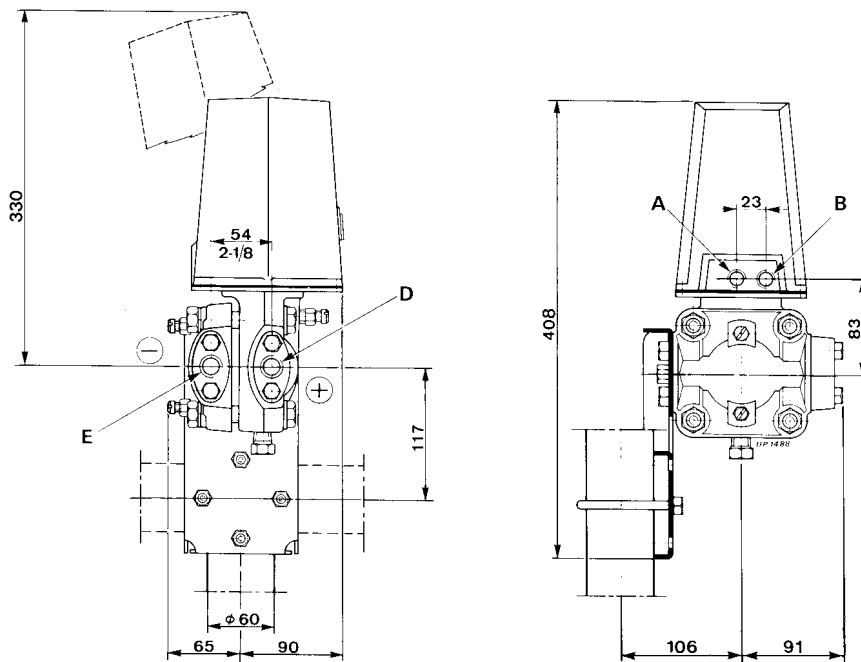

Contact us

ABB Ltd.

Process Automation

Howard Road
St. Neots
Cambridgeshire PE19 8EU
UK

Tel: +44 (0)1480 475321

Fax: +44 (0)1480 217948

ABB Inc.

Process Automation

125 E. County Line Road
Warminster
PA 18974
USA

Tel: +1 215 674 6000

Fax: +1 215 674 7183

ABB Automation Products GmbH

Process Automation

Schillerstr. 72
32425 Minden
Germany

Tel: +49 551 905 534

Fax: +49 551 905 555

ABB S.p.A.

Process Automation

Via Statale 113
22016 Lenno (CO)
Italy

Tel: +39 0344 58111

Fax: +39 0344 56278

www.abb.com

Note

We reserve the right to make technical changes or modify the contents of this document without prior notice. With regard to purchase orders, the agreed particulars shall prevail. ABB does not accept any responsibility whatsoever for potential errors or possible lack of information in this document.

We reserve all rights in this document and in the subject matter and illustrations contained therein. Any reproduction, disclosure to third parties or utilization of its contents - in whole or in parts - is forbidden without prior written consent of ABB.











Copyright© 2011 ABB

All rights reserved

3KXP900201R1001



Our offering:

	Actuators and Positioners		Analytical Instruments
	Device Management, Fieldbus and Wireless		Flow Measurement
	Force Measurement		Level Measurement
	Natural Gas Measurement		Pressure Measurement
	Recorders and Controllers		Temperature Measurement

HMI – Automação e Instrumentação, Lda.

Travessa da Indústria, nº 111
4780-573 Santo Tirso
PORTUGAL

Tel. +351 252 850 501
Fax. +351 300 013 487

Web: www.hmi.pt

Email: hmi@hmi.pt