



hmi

high-accuracy
measurement
instruments

FICHA TÉCNICA DE PRODUTO

PRODUCT DATASHEET

HMI – Automação e Instrumentação, Lda.

Travessa da Indústria, nº 111
4780-573 Santo Tirso
PORTUGAL

Tel. +351 252 850 501
Fax. +351 300 013 487

Web: www.hmi.pt

Email: hmi@hmi.pt

ABB MEASUREMENT & ANALYTICS | DATA SHEET

LMS200

Magnetic level gauge switch



Measurement made easy

Innovative level measurement solutions

Features

- unique concept of magnetic coupling, eliminating direct contact with process
- no process piping or valves required
- easy mounting and adjustment; only small screwdriver required
- trip point infinitely adjustable without changing process piping
- 10 A rated double-pole, double-throw (DPDT) switch (normally open or normally closed contacts)
- suitable for high temperature applications
- RoHS 2.0 compliant with industrial explosion proof IP66/67 and NEMA4X enclosure with ATEX/IECEX, FM US and Canada approvals

Introduction

ABB's magnetic level gauge switches provide safe and reliable liquid level detection and process control when integrated externally on the KM26 series magnetic level gauges and LS series products. These non-invasive magnetically actuated electrical switches offer complete isolation from the process fluid by coupling with the magnetic floats and attraction sleeves already present in the KM26 and LS series products. This passive, non-contact method of coupling facilitates safe operation, while also eliminating the need for costly seals, diaphragms, and process connections commonly associated with point level switch technology. The superior design enables the setpoint to be adjusted without any changes to process piping, resulting in level switches that are quickly deployed, readily adjustable, and easy to maintain.

Operation

The LMS200 is a magnetically activated double pole double throw switch. When the LMS200 is mounted on a KM26 or an external chamber that has a magnetic float it can sense high or low levels within a vessel. The LMS200 consists of two snap action switches operated by a precision actuation mechanism. The actuation mechanism consists of two cams integrated into an injection over-molded magnet. The cams rotate to depress or release the snap action switch actuators when a magnetic field of proper orientation passes near the switch. A magnetic KM26 float passing by the LMS200 in either the upward or downward direction causes the switch to change states. After the float has passed, the switch remains in its respective state until the float passes the switch going in the opposite direction. The action of the switch is break-before-make.

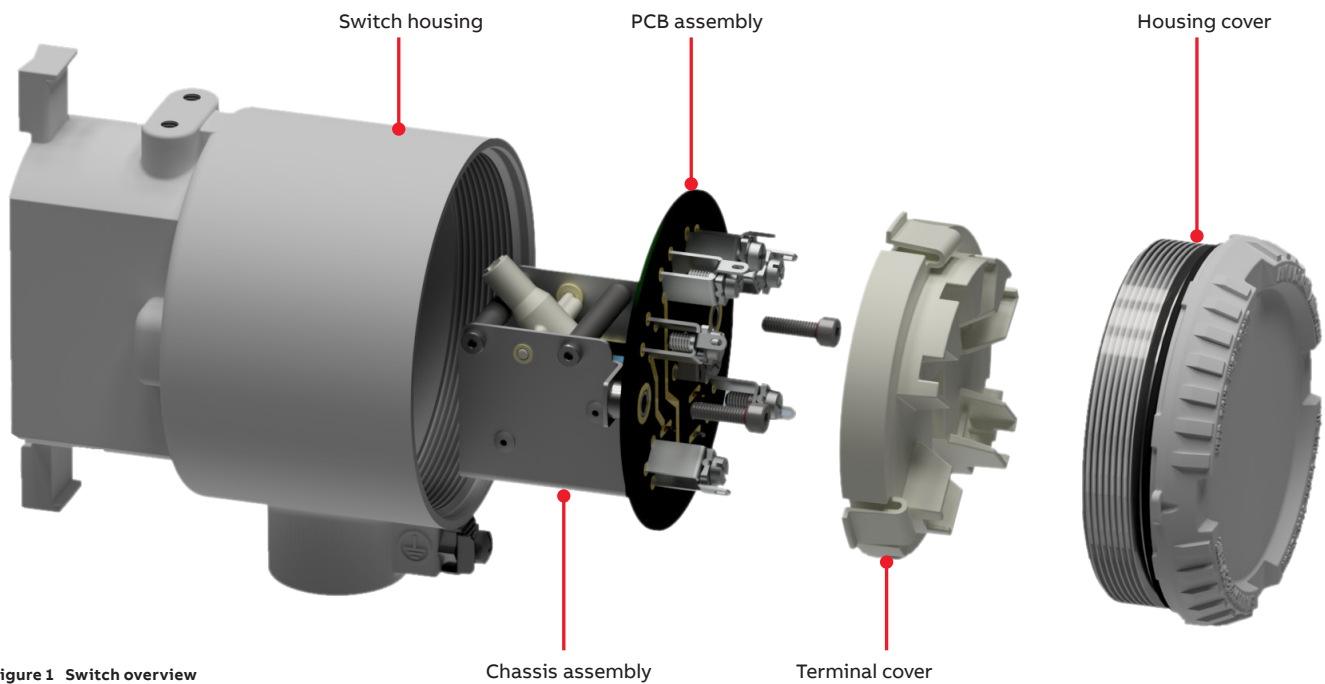

Figure 1 Switch overview

Dimensions in mm (in)

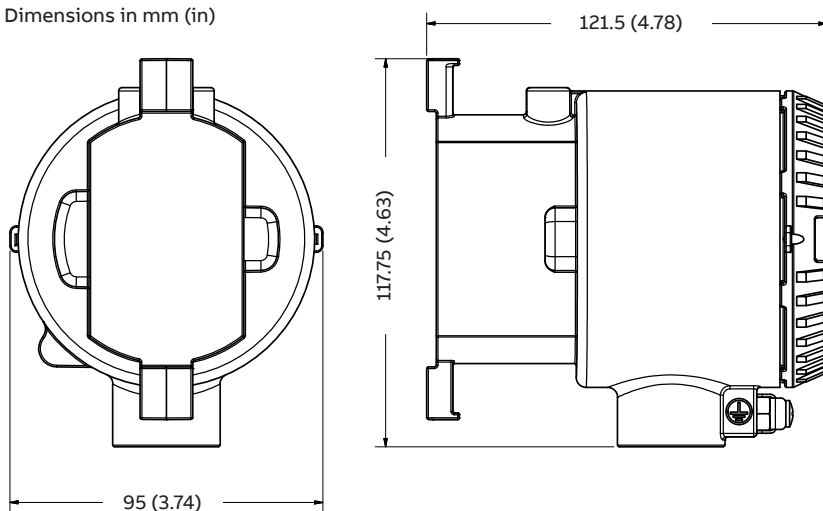

Figure 2 LMS200 Dimensions

Overview

Reliable solutions in demanding conditions

Key features



Output: 10 A @
250 V Max



+/- 0.75 in.
(1.9 cm) of
float travel



DPDT
configuration



Retrofittable in
any MLG



Installation- fast and easy



Direct and rod
mount options



No field
calibration



Spacious and
safer wiring
terminals

Wide environmental conditions



RoHS 2.0



ATEX/IECEX, FM US and FM Canada



IP 66/67



$-40^{\circ}\text{C} \leq T_A$
 $\leq 70^{\circ}\text{C}$

...Overview

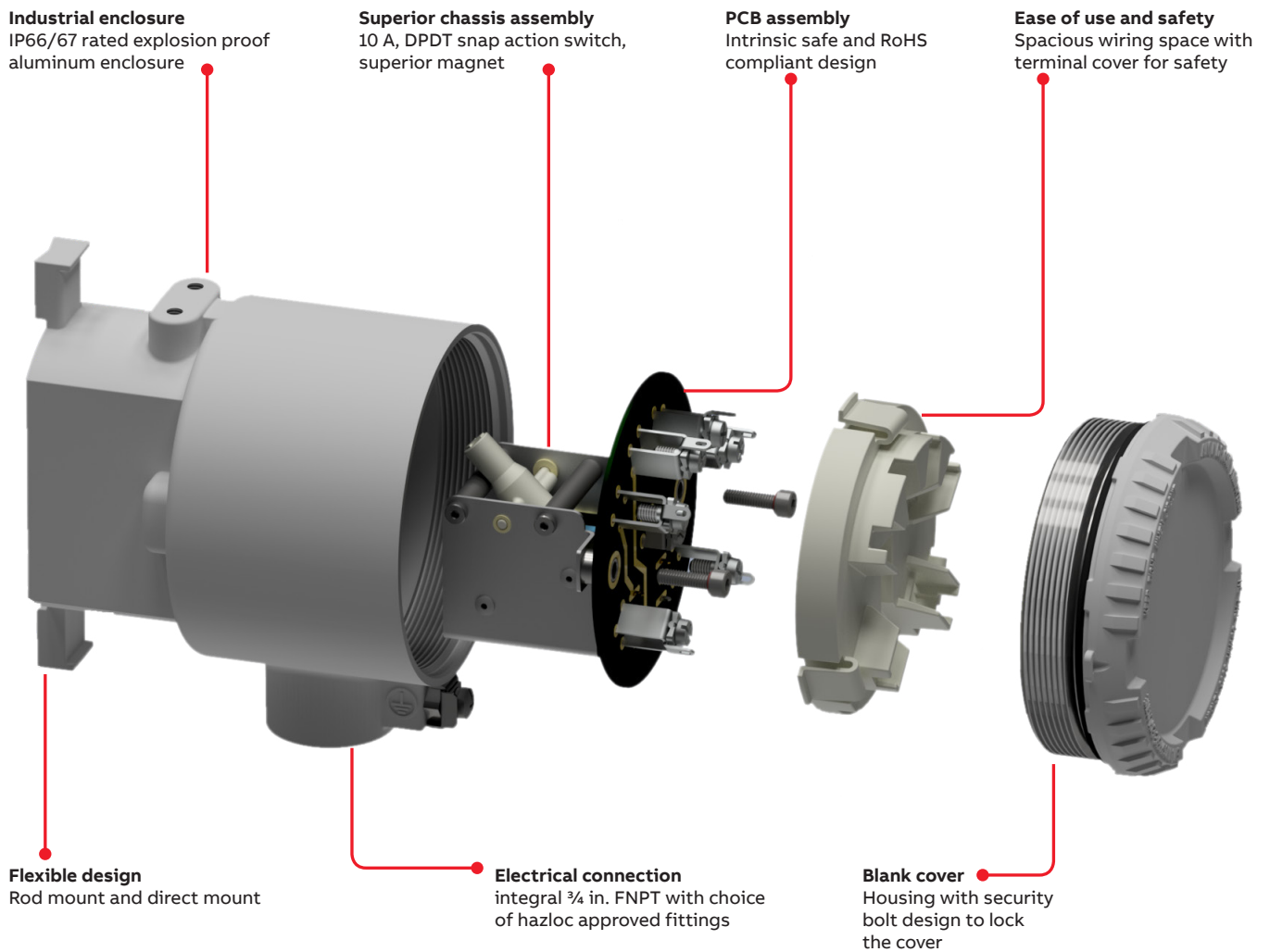

Application

The LMS200 provides double-pole, double-throw (DPDT) switching in the form of two isolated normally open or normally closed contacts. Since the switch is configured in a double pole double throw configuration, two separate devices can be controlled with the same switch. The current switching capacity of the switch allows for a wide variety of devices to be switched as long as the stated limits are not exceeded. Since the LMS200 is magnetically actuated, it is suited for any application where it is necessary to sense the passing of a magnetic float on a KM26, or similar chamber, attached to a vessel containing fluid. This will provide for the detection of a start/stop trip point of either a total or interface level of any vessel. These trip points can be used for alarms or to activate a pump motor starter relay.

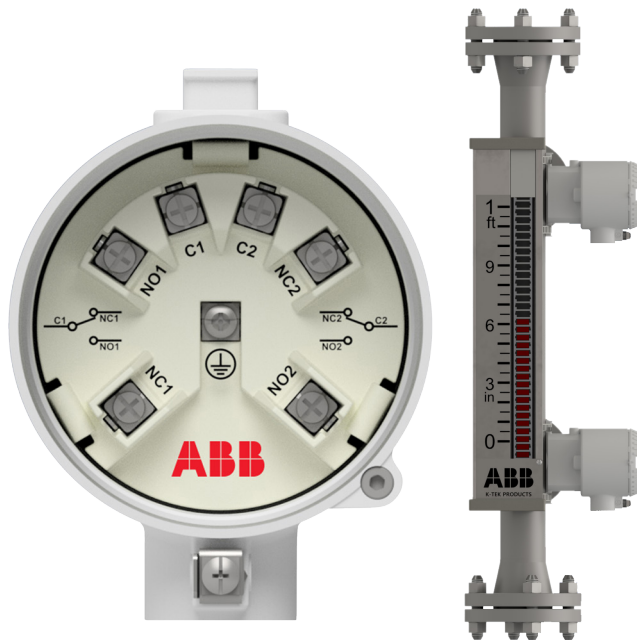

Figure 3 Switch mounting and wiring

Mounting

In the direct mounting option, the LMS200 is mounted using two stainless steel clamps that pass over the tabs mounted to the switch housing (see Figure 4). The clamp is then fastened to the KM26, or similar chamber. The switch can be easily positioned by loosening the clamp with a screwdriver and sliding the switch to the correct position on the chamber. Other switches can be added at any time, without the concern for additional process piping or valves.

For high temperature applications using insulation jackets (blankets) this alternate mounting approach of rod mounting is used (see Figure 5). When mounting / adjusting rod-mounted LMS200s, ensure that the mounting 'ears' of the switch are flush against the float chamber or insulation jackets (blankets) to allow proper switch function. Also, be sure to tighten all mounting bolt hardware once switch is correctly mounted into position.

General recommendation for mounting:

- if an insulation jacket is used, rod mount brackets are required.
- if insulation pads are used, stainless steel gear clamps are required.

The table below defines the recommended insulation and mounting configurations based on process temperature.

Process temperature	Insulation	Mounting
Up to 257 °F (125 °C)	None (Y0)	Standard (A1)
Up to 350 °F (176.6 °C)	None (Y0)	*Rod mount (A2)
Up to 575 °F (301.6 °C)	Insulation pad (P1)	Standard (A1)
Up to 800 °F (426.6 °C)	Chamber insulation	Rod mount (A2)

* Ensure >2 mm (0.008 in.) air gap between the target chamber and the LMS200 mounting surfaces

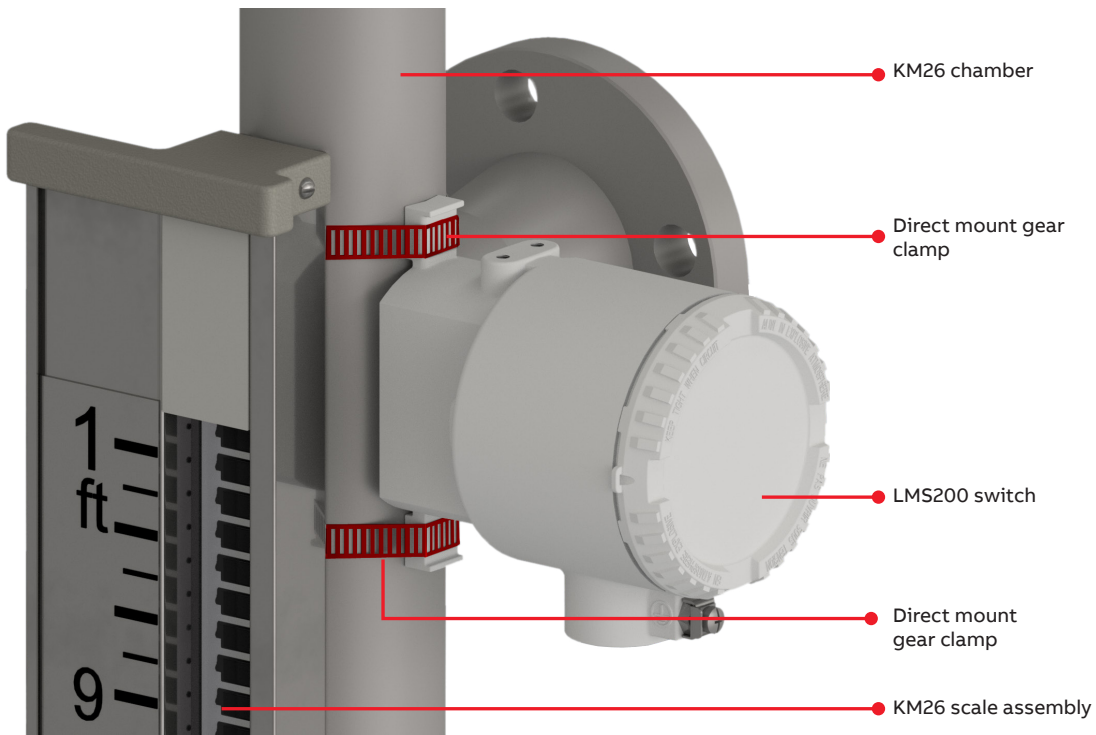

Figure 4 Direct mounting

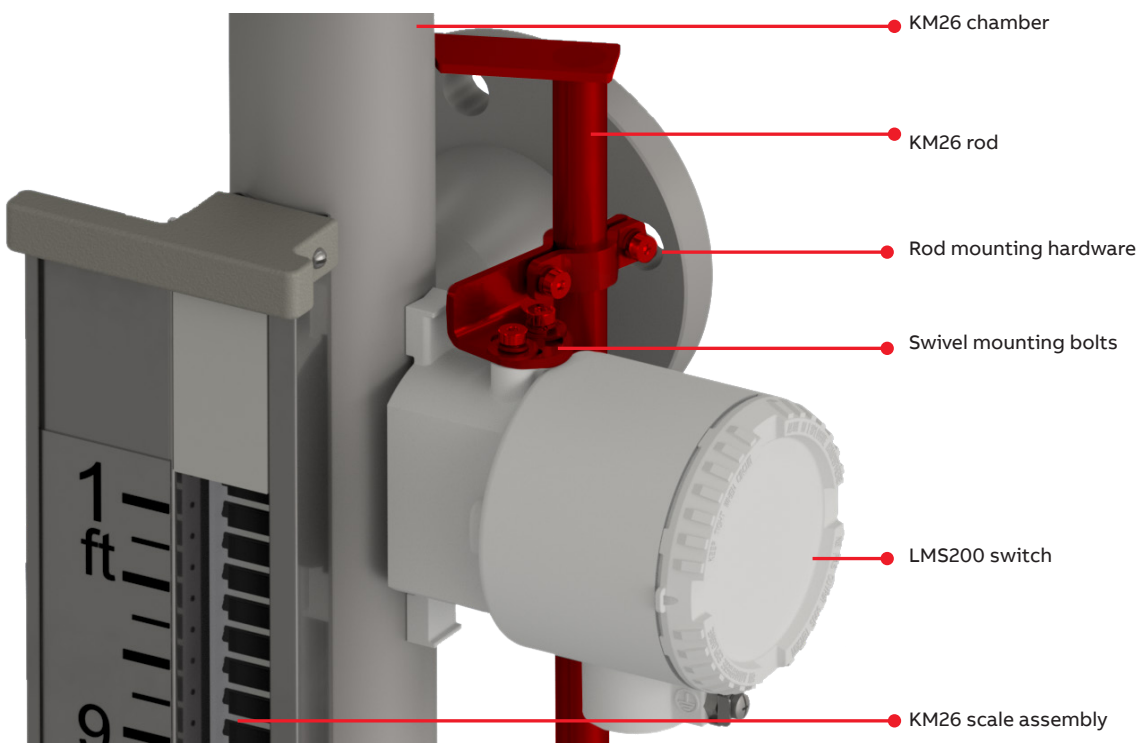

Figure 5 Rod mounting

LMS200 overview

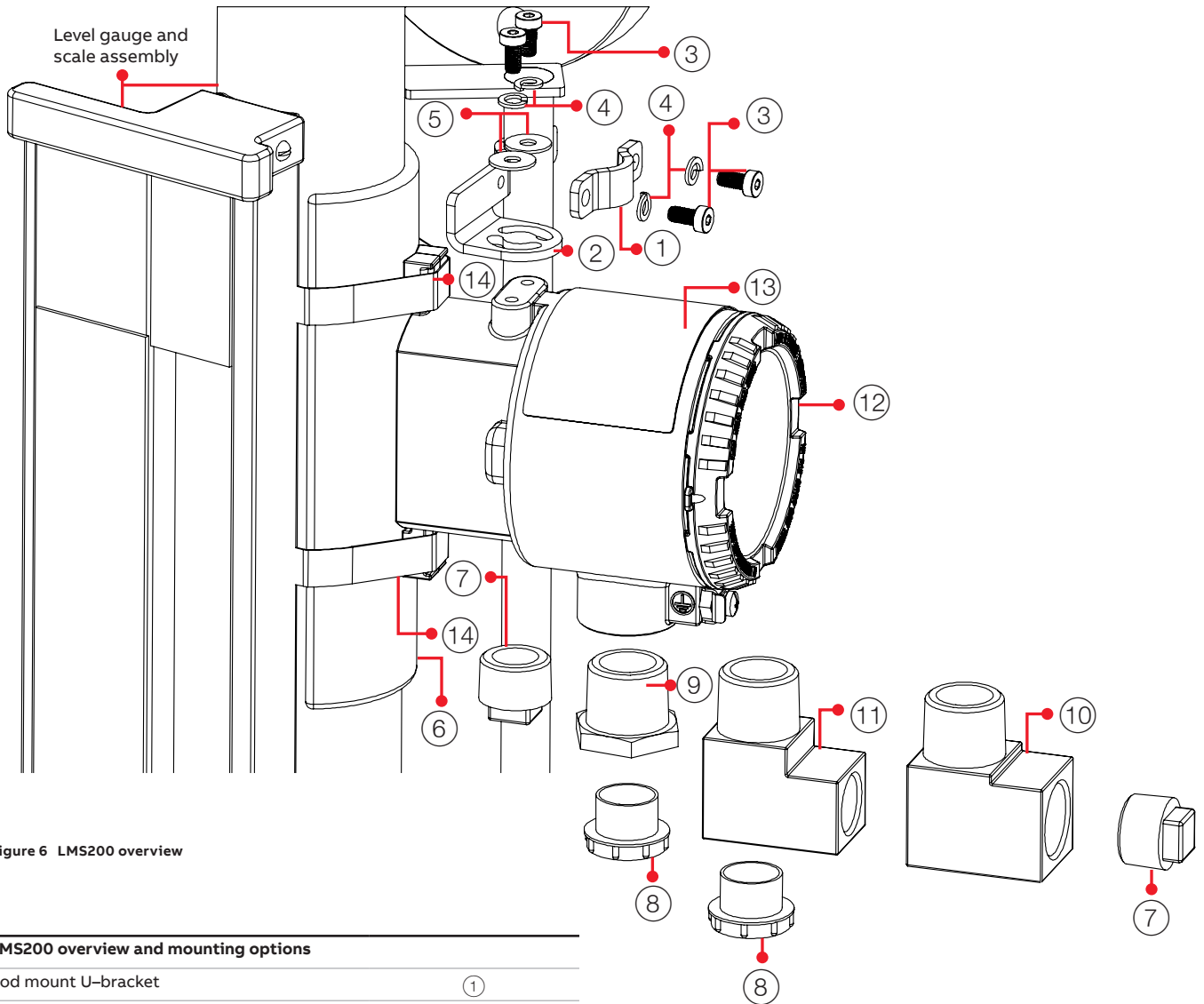

Figure 6 LMS200 overview

LMS200 overview and mounting options

Rod mount U-bracket	(1)
Rod-switch bracket	(2)
M5 socket cap head screw	(3)
Split lock washer	(4)
Flat washer	(5)
Insulation pad	(6)
3/4 in MNPT plastic plug	(7)
M20 plastic plug	(8)
3/4 in MNPT x M20F thread reducer	(9)
3/4 in MNPT x 3/4 in FNPT 90° thread adapter	(10)
3/4 in MNPT x M20F 90° thread adapter	(11)
LMS200 magnetic level gauge switch	(12)
Product nameplate	(13)
Gear clamp	(14)

Specification

Switch type

RoHS 2.0 compliant, magnetically actuated DPDT electrical switch, cam driven snap action bistable switch

Contact material

Silver Alloy – AgNi10

Switch Action

Break-before-make

Max deadband

Approx. ± 1.9 cm (0.75 in) of float travel

Contact ratings

AC rating: 10 A resistive, ¼ HP @ 125 AC or 250 V AC

Minimum operating temperature

–40 °C (–40 °F)

Maximum operating temperature

125 °C (257 °F)

See mounting options for process temperatures up to 427 °C (800 °F)

Vibration

Acceleration: 1 g

Frequency range: 10...500 Hz

Amplitude (max): 0.15 mm

Standard: IEC 60068-2-6

Shock

Acceleration: 5 g

Duration: 11 ms half-sine

Standard: IEC 60068-2-29

Mounting options

Process temperature	Insulation	Mounting
Up to 257 °F (125 °C)	None (Y0)	Standard (A1)
Up to 350 °F (176.6 °C)	None (Y0)	*Rod mount (A2)
Up to 575 °F (301.6 °C)	Insulation pad (P1)	Standard (A1)
Up to 800 °F (426.6 °C)	Chamber insulation	Rod mount (A2)

* Ensure >2 mm (0.008 in.) air gap between the target chamber and the LMS200 mounting surfaces

Housing

Powder coated and copper free aluminum, IP66/67 NEMA type 4X

Hazardous Area Rating

–40 °C ≤ T_A ≤ 70 °C

FM US / FM-C

(FM17US0304X / FM17CA0157X)

IS: CLI GP ABCD T6...T5

CLII GP EFG T6...T5; CLIII T6...T5

CLI Zn0 AEx ia IIC T6...T5

Ex ia IIC T6...T5 Ga

Zn20 AEx ia IIIC T85°C...T450 °C

XP: CLI GP ABCD T6...T1

CLII GP EFG; CLIII T6...T3B

CLI Zn1 AEx/Ex db IIC T6...T1 Gb

Zn21 AEx/Ex tb IIIC T85°C...T165°C Db

NI: CLI DIV2 ABCD T6...T5

CLII DIV2 EFG T6...T5; CLIII T6...T5

ATEX / IECEx

II 2 G, Ex db IIC T6...T1 Gb

II 2 D, Ex tb IIIC T85°C...T450°C Db FM17ATEX0090X, IECEx

FMG 17.0031X

II 1 G, Ex ia IIC T6 Ga

II 1 D, Ex ia IIIC T85°C Da FM17ATEX0089X, IECEx FMG

17.0031X

Electrical Cable Connections

Standard: ¾ in. FNPT

Optional: metric adapter and 90° NPT elbow connections

Accessories

PP10 PUMP-PAK Controller. See document DS_IR10_PP10-EN for details.

Ordering information

Mandatory characteristics	LMS200			
Approvals	xx	xx	xx	xx
General purpose	Y0			
ATEX (all applicable protection concepts)	E5			
IECEX (all applicable protection concepts)	E6			
FM / FM-C (all applicable protection concepts)	N4			
Multi-agency approval – FM, FM-C, ATEX, & IECEX (all applicable protection concepts; standard electrical connection size only)	M1			
Mounting¹				
Standard– direct gear clamp mount, process temperatures up to 125 °C (257 °F)		A1		
Rod mount– process temperatures up to 176.6 °C (350 °F), up to 426.6 °C (800 °F) with chamber insulation blanket		A2		
Insulation				
None			Y0	
Insulation pad– process temperatures up to 301.6 °C (575 °F) with standard gear clamp mount			P1	
Electrical cable connection				
Standard – ¾ in FNPT, approved for use in hazardous areas				A1
Metric adapter (stainless steel) – ¾ in MNPT X M20F reducer, approved for use in hazardous areas				A2
Metric adapter (nickel-plated brass) – ¾ in MNPT X M20F reducer, approved for use in hazardous areas				A3
90° NPT adapter (stainless steel) – ¾ in MNPT X ¾ in FNPT 90° elbow for cryogenic insulation applications, approved for use in hazardous areas				C1
90° NPT adapter (nickel-plated brass) – ¾ in MNPT X ¾ in FNPT 90° elbow for cryogenic insulation applications, approved for use in hazardous areas				C2
90° M20 adapter (stainless steel) – ¾ in MNPT X M20F elbow for cryogenic insulation applications, approved for use hazardous areas				C3
90° M20 adapter (nickel-plated brass) – ¾ in MNPT X M20F elbow for cryogenic insulation applications, approved for use hazardous areas				C4
Special				Z9

¹ Refer to the mounting section of this document for the recommended mounting and insulation configurations by process temperature.

Optional characteristics	LMS200	
Services		xxx
Certificate of origin		GS1
Certificate of functionality		CU3
Accessories ordered separately	LMS200	
Pump pack controller (PP10)		AR2

ABB Inc.**Measurement & Analytics**

125 E. County Line Road
Warminster, PA 18974
USA

Tel: +1 215 674 6000

Fax: +1 215 674 7183

ABB Engineering (Shanghai) Ltd.**Measurement & Analytics**

No. 4528, Kangxin Highway
Pudong District, Shanghai
201319

P.R. China

Phone: 4008209696

Fax: +86 21 61056677

Email: instrumentsservice.abbchina@cn.abb.com

abb.com

abb.com/level

ABB Inc.**Measurement & Analytics**

8490 Bluebonnet Blvd
Suite 100
Baton Rouge, LA 70810
USA

Tel: +1 225 408 0800

Service: +1 225 677 5836

Fax: +1 225 673 2525

Email: quotes.ktek@us.abb.com











Service email: ktek-service@us.abb.com

We reserve the right to make technical changes or modify the contents of this document without prior notice. With regard to purchase orders, the agreed particulars shall prevail.
ABB does not accept any responsibility whatsoever for potential errors or possible lack of information in this document.

We reserve all rights in this document and in the subject matter and illustrations contained therein. Any reproduction, disclosure to third parties or utilization of its contents – in whole or in parts – is forbidden without prior written consent of ABB.



Our offering:

	Actuators and Positioners		Analytical Instruments
	Device Management, Fieldbus and Wireless		Flow Measurement
	Force Measurement		Level Measurement
	Natural Gas Measurement		Pressure Measurement
	Recorders and Controllers		Temperature Measurement

HMI – Automação e Instrumentação, Lda.

Travessa da Indústria, nº 111
4780-573 Santo Tirso
PORTUGAL

Tel. +351 252 850 501
Fax. +351 300 013 487

Web: www.hmi.pt

Email: hmi@hmi.pt