



hmi

high-accuracy
measurement
instruments

FICHA TÉCNICA DE PRODUTO

PRODUCT DATASHEET

HMI – Automação e Instrumentação, Lda.

Travessa da Indústria, nº 111
4780-573 Santo Tirso
PORTUGAL

Tel. +351 252 850 501
Fax. +351 300 013 487

Web: www.hmi.pt

Email: hmi@hmi.pt

ABB MEASUREMENT & ANALYTICS | DATA SHEET

LM200 Laser level transmitter

Measurement made easy
Long range level products



Level measurement made easy

- Maintenance free, non-contact continuous level transmitter
- No calibration required
- Continuous level monitoring for granular solid materials and opaque liquids
- Measures solids and opaque liquids at any angle
- Built-in laser pointer for accurate alignment in narrow or tall vessels
- Auto-ranging to measure all levels
- Available non-condensing heated optics prevent condensation issues

A convenient solution

- Rugged and robust powder coated aluminum enclosure for use in harsh environments
- CSA, ATEX and IECEx potentially explosive atmosphere ratings
- Easy to install and configure without filling or emptying the vessel
- 4–20 mA and dual relay outputs

High performance

- Less than 0.2° beam divergence for precision targeting
- No false echoes
- Range up to 190 m (620 ft.) for level applications
- And up to 400 m (1312 ft.) for positioning applications
- Three updates per second
- Can penetrate moderate dust

Many different materials

- Measures all clearly visible surfaces irrespective of texture, granularity, slope and / or color
- Measures any opaque liquid level independent of dielectric constant or other physical properties
- Accurately measures to the surface of mineral ores, grains, and synthetic materials
- Examples include: gold and metal ores, coal, corn, rice, coffee, plastic pellets, oils and fuels

Many different vessels and conditions

- Works in all types of storage vessels including silos, tanks, feed chutes, bunkers and hoppers
- Can measure through narrow gaps
- Reads to the bottom of silos and tanks

Options and accessories

- Stainless steel dust tubes
- Stainless steel 4 and 6 inch universal mounting plates sized for ANSI 150 and DIN PN10 flanges
- Stainless steel raised face ANSI and DIN Flanges
- Handheld configuration device (LCD2)

Overview

The laser level transmitter (LM200) is a non-contact, level and distance measuring instrument designed for granular solid materials and opaque liquids. Based on pulsed laser technology, the LM200 embodies speed and accuracy in a single, easy to use and install product. The characteristic narrow beam divergence of the laser permits direct aiming to the target surface without interference from structure or falling material. With both continuous 4–20 mA and single point relay outputs, the LM200 can operate as a process control transmitter while simultaneously providing high and low alarms. Whether measuring a few meters into the confined space of a crusher, or to the bottom of the tallest silo, the LM200 with its laser pointer and long range is the plug-and-play solution to level measurement.

Level and distance measurement with laser technology

The LM200 uses a high speed laser pulse to measure distance. The laser light is emitted towards the surface and some of it reflects back to the instrument where it is detected by a sensitive optical receiver. The time it takes for the light to travel to the surface and back to the instrument is directly proportional to the distance between the instrument and the surface. Using a time-of-flight calculation, and knowing the height of the vessel, the LM200 accurately measures the distance to the target surface using the equations below:

$$\text{Distance} = \frac{\text{speed of light} \times \text{time-of-flight}}{2}$$

$$\text{Level} = \text{Height} - \text{Distance}$$

The unique characteristics of laser light give the LM200 significant performance advantages over other technologies. The narrow, long range beam can measure both near and far distances while the optical wavelength makes it easy to evaluate applications. If you can see the surface clearly, the LM200 can measure the distance.

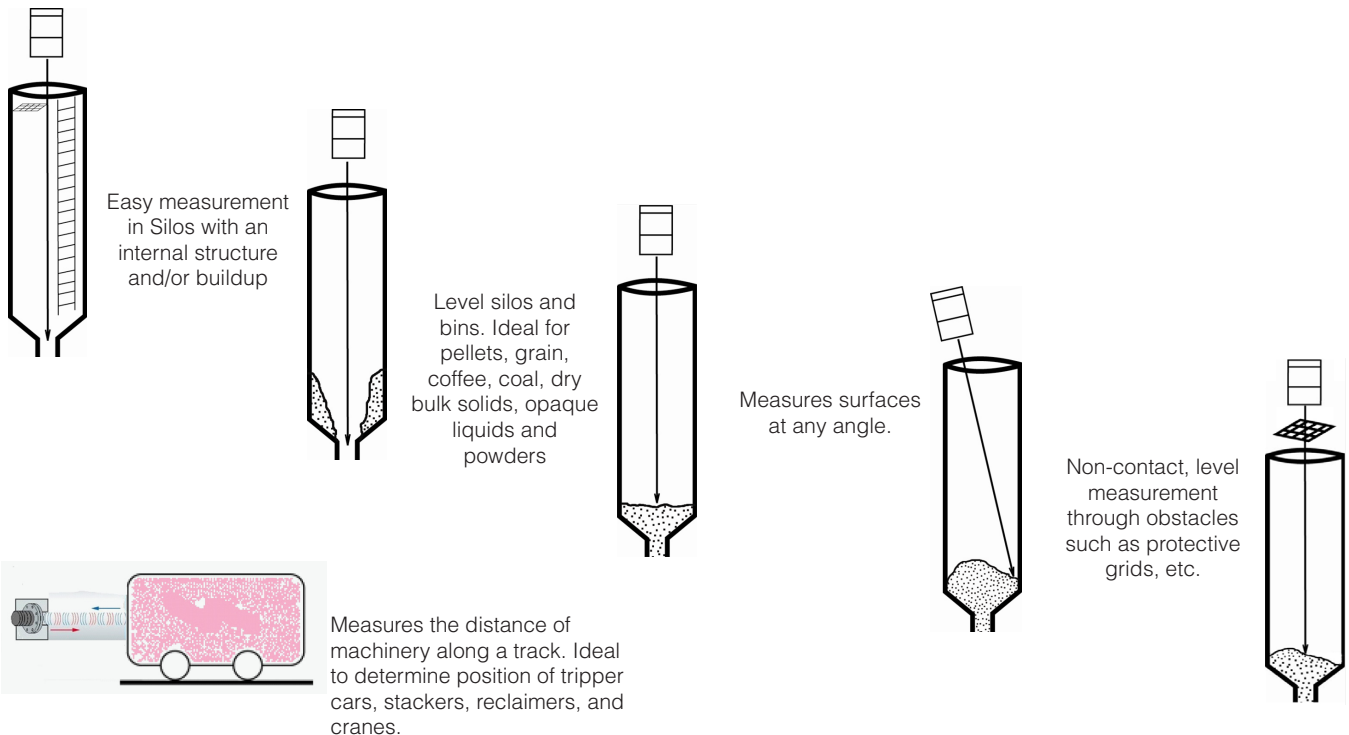

Range guide

The LM200 is mounted on top of a storage vessel aiming downwards towards the surface. Using the visible laser pointer, the position and angle of the LM200 can be adjusted so that the instrument measures all the way to the bottom of the vessel. Settings such as: the distances for the 4–20 mA output; and the relay switching points, can be entered into the instrument either before installation, or in situ using the laser configuration (LCD2) accessory. Another recommended accessory is the stainless steel dust tube (P201) which keeps the optical system of the LM200 clean for long periods.

Range explained

The LM200 is able to measure the level in tall silos because of the inherent long distance capability of laser technology. The laser has a natural advantage because it gets strong, clear signals from most types of granular solid materials. As the laser beam does not spread out and lose strength as it travels, there is little signal loss with increased distance.

Auto-ranging

Auto-ranging is a hardware feature which increases the range of the internal timing circuitry of the LM200. It does this in response to the 4–20mA or relay set points that are entered by the user. If these settings are less than 35 m (114.8 ft) then automatic “Range 1” is used. Between 35 m (114.8 ft) and 85 m (278.9 ft), automatic “Range 2” is selected. As the LM200 switches between these ranges there is no loss of accuracy, only a slight reduction in measuring speed.

Ultimate range

The ultimate limit of range for the LM200 depends on the reflectivity of the material being measured, not on the height of the vessel. Dark colored materials can be measured over a shorter range than light colored materials. Using the chart on the left, a visual comparison between the graded “Visual range guide” strip and the surface to be measured tells you what range is practically possible.

When the LM200 is used for positioning applications with a reflective target it can measure to a maximum distance of 400 m (1300 ft).

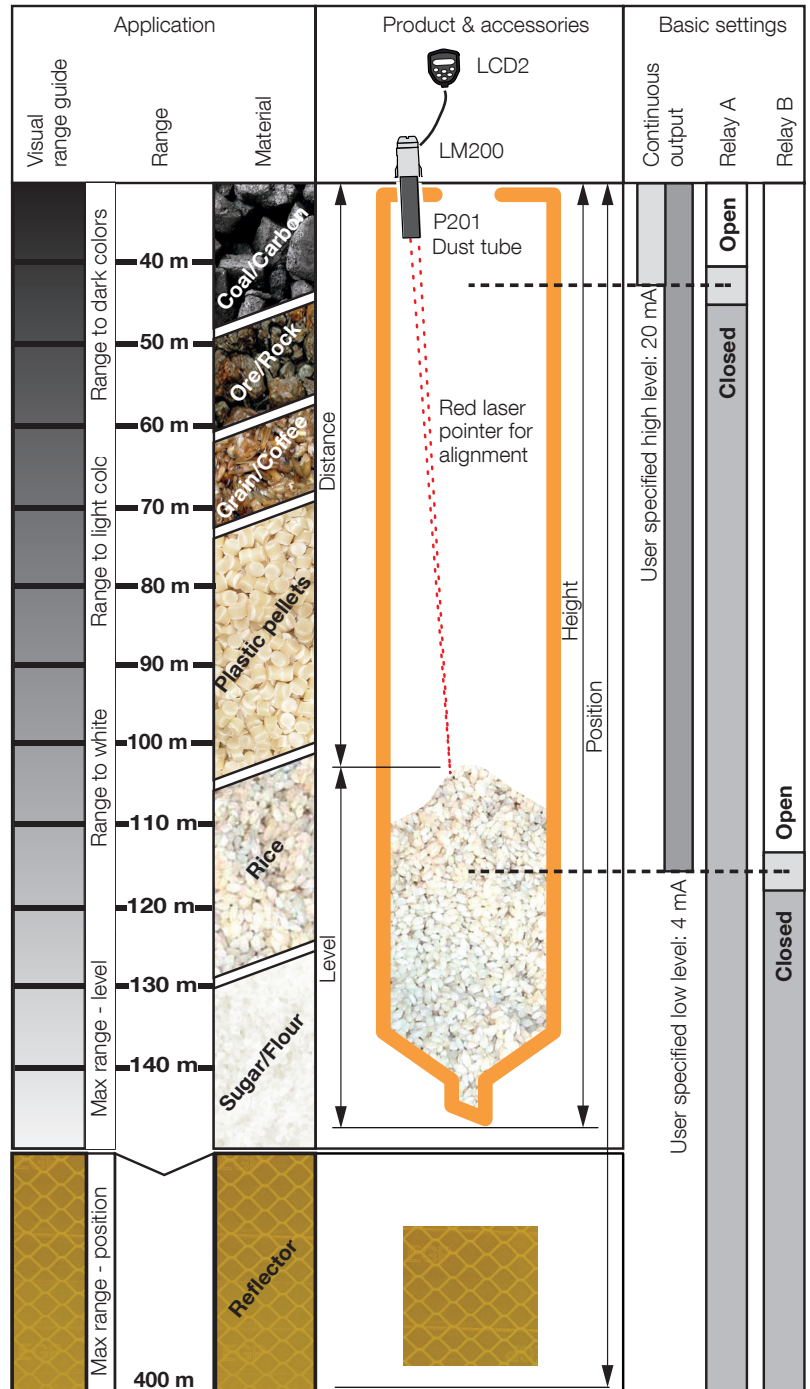

Specifications

Measurements

Range

- 0.5 m (1.5 ft) to 40 m (131 ft) - dark colored surfaces
- 0.5 m (1.5 ft) to 190 m (623 ft) - light colored surfaces
- 0.5 m (1.5 ft) to 400 m (1300 ft) - reflective targets in positioning applications

Resolution

±10 mm (0.4 in)

Accuracy

±30 mm (1.2 in)

Update rate

3 readings per second (maximum), 1 reading per minute (minimum)

Operating temperature

−40°C to +60°C (−40°F to +140°F)

Note: While the initial (cold start) accuracy of the LM200 will be within specifications, a settling period of approximately 15 minutes is recommended to allow the electronics to warm up and the internal temperature to stabilize.

Survival temperature

−40°C to +80°C (−40°F to +176°F)

Pressure

Atmospheric

Outputs

Analog

4–20 mA, NAMUR compliant non-isolated and self powered

Digital (Relay)

2 SPST relays: 1 A at 120 VAC, 0.5 A at 250 VAC, 1 A at 60 VDC

Communication

Standard male DB9 connector - RS232 for testing, troubleshooting and configuration
19200 baud, 8 data bits, 1 stop bit, no parity, no flow control

Power supply

Voltage

24 V DC typical (18 to 32 V DC)

Current

0.4 A peak (less than 100 ms), 0.2 A continuous
0.55 A peak, 0.35 A continuous with non-condensing optics

Mechanical

Base plate diameter

127 mm (5 in)

Length

303 mm (12 in)

Weight

Aluminum enclosure - 3.86 kg (8.5 lbs)

Enclosure material

Powder coated aluminum standard

O-ring seal material

Buna-N (Nitrile Rubber)

Mounting / process connection

Flange - 4 holes to allow bolting on a flange or bracket with 4 M6 screws.

Optical

Total optical aperture

100 mm (4 in)

Measuring laser lens diameter

50 mm (1.97 in)

Receiver lens diameter

50 mm (1.97 in)

Lens material

Glass

Lens impact resistance

Impact tested at 4 joules

Beam divergence

$\Delta < 0.2^\circ$

Beam spot diameter

$$2R \tan\left(\frac{\Delta}{2}\right)$$

Where R is the range to the target and Δ is the beam divergence

Beam direction

$90^\circ \pm 1^\circ$ from mounting flange

Specifications

Laser

Measuring laser

- 905 nm near infrared pulsed semiconductor laser
- 12 mW average power output
- 20 W peak power output

Pointing laser

- 635 nm red semiconductor laser
- 3 mW continuous

Measuring laser life expectancy

- 25 years typical MTBF

Measuring laser safety



Always on IEC60825-1 class 1M laser
A class 1M laser is safe for all conditions of use except when passed through magnifying optics. This means the maximum permissible exposure cannot be exceeded when viewing the laser with the naked eye without the aid of magnifying optics.

Pointing laser safety



Intermittent IEC80825-1 class 3R laser
Laser comes on at power up for 2 minutes, it can be turned back on for commissioning using the LCD2 communications and configuration device.
A class 3R laser is considered safe if handled carefully, with restricted beam viewing. With a class 3R laser the maximum permissible exposure can be exceeded when viewing the laser with the naked eye, but with a low risk of injury.

Purge for use with the dust tubes

Purge air flow

- Must be oil free dry air
- recommended flow between 0.5 and 4 L/minute
- maximum pressure 5.5 bar (80 psi)

Purge fitting

- 1/8 NPT (to be connected on the dust tubes)

Environmental

Enclosure rating

- IP66/Nema 4X (Dust proof, can be washed down with high pressure hose)

Gas rating



- This equipment can be used in flammable gases or vapor hazardous locations.

Documentation for LM200 laser level transmitter is available for download from www.abb.com/level

Specifications

Approvals

The instrument is certified with the following environmental safety ratings which must not be exceeded. Copies of instrument certifications are available on request.

<p>CE</p> 	<p>Quality standard : ISO9001:2015 ATEX directive 2014/34/EU Electromagnetic compatibility directive 2014/30/EU Low voltage directive 2014/35/EU CE marking directive 93/68/EEC</p>	<p>Harmonized standards applied: EN 60079-0:2012, EN 60079-15:2010 EN 60079-28:2007, EN 60079-31:2009 EN 61000-6-2: electromagnetic compatibility (EMC). Generic standards, Immunity standard for industrial environments. EN 61000-6-4: electromagnetic compatibility (EMC). Generic standards, Emission standard for industrial environments.</p>
<p>ATEX, IECEx</p>   	<p>Notified body: CSA Group Netherlands B.V., Notified Body Number 2813 II 3G Ex nA nC IIC T4 Gc (-40 °C ≤ Ta ≤ +60 °C) II 3G Ex op is IIC T4 Gc (-40 °C ≤ Ta ≤ +60 °C) II 2D Ex tb IIIC T85°C Db (-40 °C ≤ Ta ≤ +60 °C)</p>	<p>Sira 13ATEX4027X IECEX SIR 13.0016X Sira 13ATEX9028X</p>
<p>CSA</p> 	<p>Class I, Division 2, Groups A, B, C and D; Class II, Groups E, F and G, Class III; T6; (-40 < Ta < +60°C) Ex nA nC IIC T4; Ex tb IIIC T85°C (-40 < Ta < +60°C) Class I, Zone 2, AEx nA nC IIC T4; Class I, Zone 2, AEx op is IIC T4 Gc Class II, AEx tb IIIC T85°C, Type 4X enclosure, IP66.</p>	
<p>FM</p> 	<p>Non-Incendive for Class I, Division 2, Groups A, B, C, and D, temperature class T4; Dust Ignitionproof for Class II and III, Division 1, Groups E, F, and G, T6; Non-sparking with Enclosed Break Contacts AEx nA nC IIC T4 for Class I, Zone 2; and Protection by enclosure for Zone 21 as AEx tb IIIC T85°C hazardous (classified) locations, indoor/outdoor Type 4X/IP66. Ambient temperature range for equipment is -40°C to +60°C.</p>	
<p>Custom Union & Metrology</p> <p>Kazakhstan</p> 	<p>2Ex nA nC IIC T4 Gc X, 2Ex op is IIC T4 Gc X, Ex tb IIIC T85 °C Db X RU C-CA.AA87.B.00863 Ta = -40 °C ≤ Ta ≤ +60 °C (-40 °F ≤ Ta ≤ +140 °F) PAC No: 61250-15 # KZ38VTN00004890 Certificat N°862</p>	
<p>KOSHA-KTL</p> 	<p>Certificat # 2017-077345-01 LM200 (Ex nA nC IIC T4, Ex tb IIIC T85°C)</p>	

Electrical connections

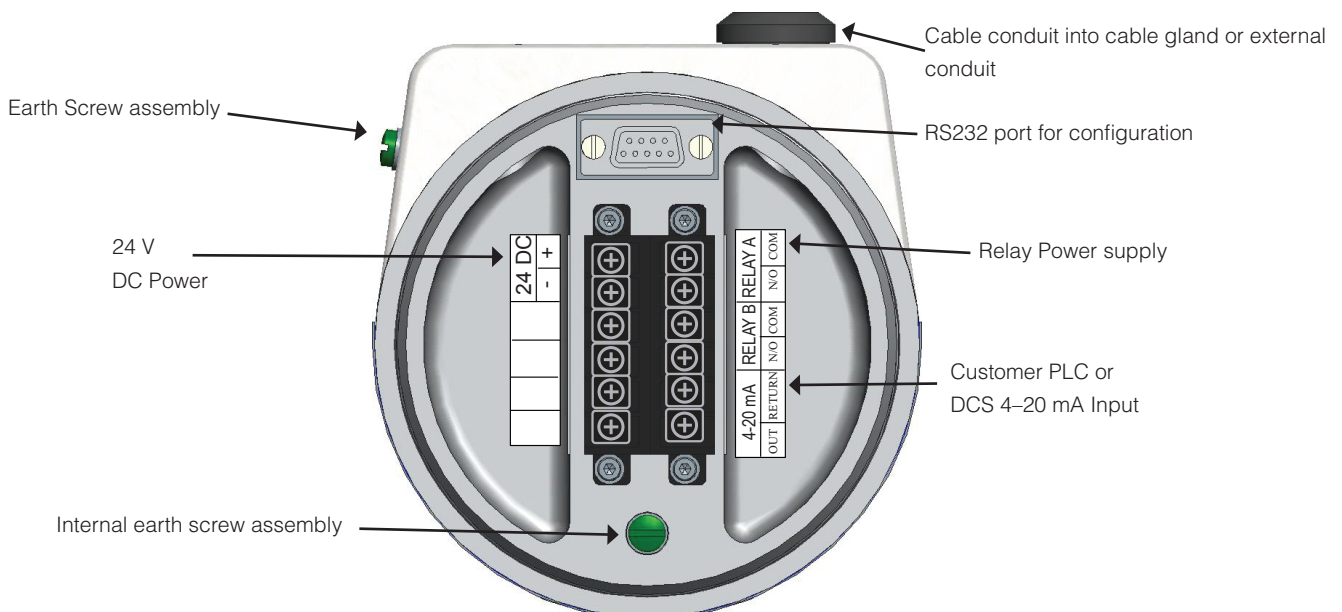

Figure 1 Electrical connections

Dimensions

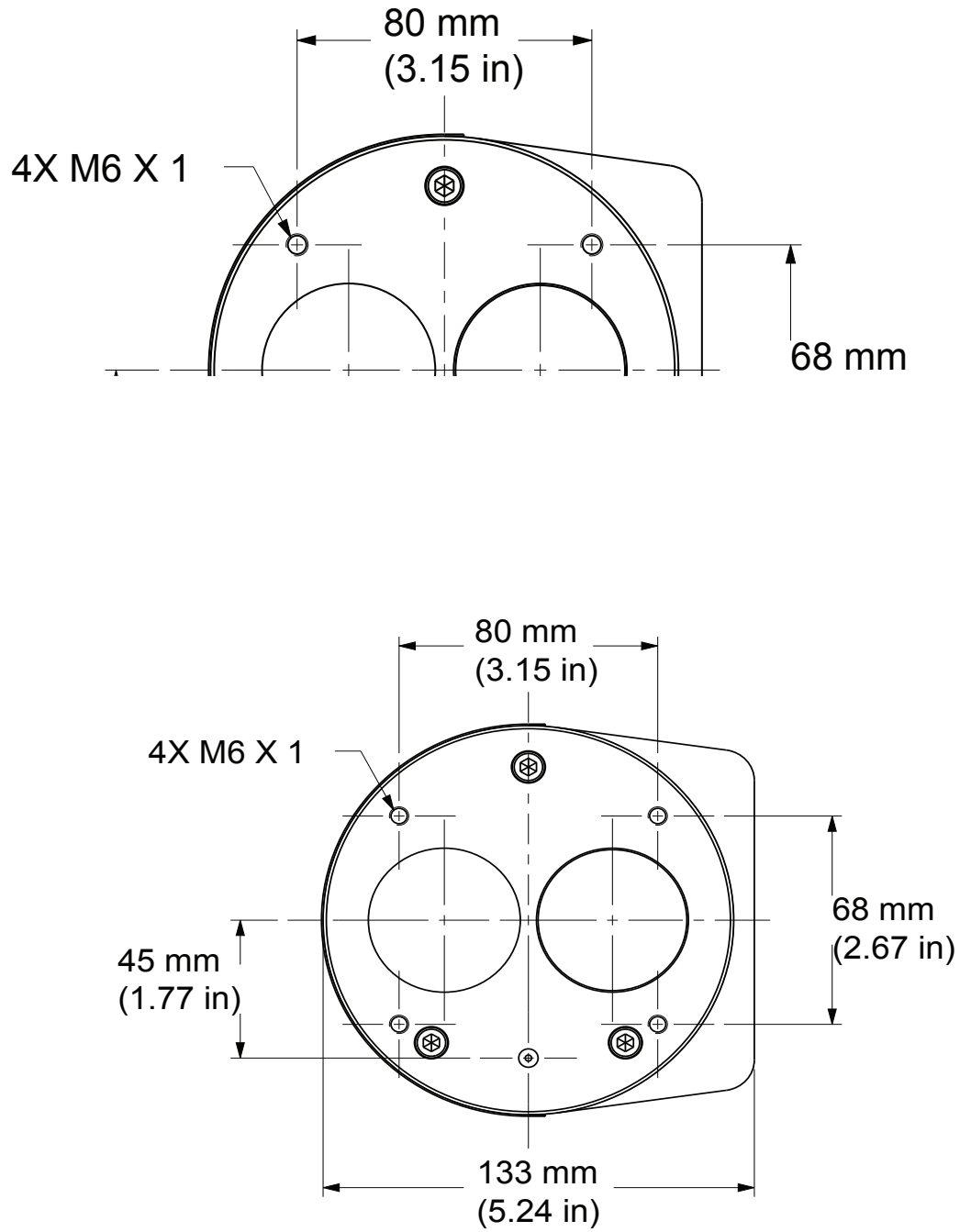

Figure 2 Dimensions

Accessories — specifications

Dust tube (P201)

Base plate diameter

127 mm (5 in) mounts on LM200 standard flange

Length

257.2 mm (10.125 in)

Material

304 Stainless steel

Gasket material

Black neoprene rubber durometer rating shore 60A

Function

Static air space prevents dust buildup, can be purged

Mounting plates

Nominal diameter	4 in / DN 100	6 in / DN 150
Part number	P204	P206
Outer diameter	228 mm (8.96 in)	284 mm (11.18 in)
Mounting bolt pattern	Dual pattern ANSI/DIN ANSI class 150 : 8 bolts, size 5/8 in, bolt circle 7.5 in DIN PN 10 : 8 bolts, size 18 mm, bolt circle 180 mm	Dual pattern ANSI/DIN ANSI class 150 : 8 bolts, size 3/4 in, bolt circle 9.5 in DIN PN 10 : 8 bolts, size 22 mm, bolt circle 240 mm
Material	304 Stainless steel	
Pressure rating	No pressure rating, atmospheric pressure only	

Mounting flanges

Nominal diameter	4 in raised face	6 in raised face	DN 100	DN 150
Part number	F204	F206	F210	F215
Outer diameter	9 in	11 in	220 mm	285 mm
Mounting bolt pattern	ANSI class 150 8 bolts, size 5/8 in Bolt circle 7.5 in	ANSI class 150 8 bolts, size 3/4 in Bolt circle 9.5 in	PN 10 8 bolts, size 18 mm Bolt circle 180 mm	PN 10 8 bolts, size 22 mm Bolt circle 240 mm
Material	304 Stainless steel			
Pressure rating	No pressure rating, atmospheric pressure only			

Adjustable pivot bracket (A200)

Outer diameter / width

160 mm (6.3 in)

Opening diameter

90 mm (3.54 in)

Mounting plate thickness

4.76 mm (0.19 in)

Mounting bolt

HHCS screw 5/16-18, bolt hole 8.33 mm (0.33 in)

Height of pivot

25.4 mm (1 in)

Tilt angle for aiming

Continuously adjustable over 180°

Material

304 Stainless steel

Accessories — specifications

Communication/configuration device and local display (LCD2)

Protocol

RS232 ASCII menus

Connector

Standard female DB9

Interface

Monochrome LCD display / 6 button keypad

Size

Width 55 mm (2.17 in), Height 97 mm (3.82 in), Thickness 32.5 mm (1.28 in)

Material

Plastic enclosure

Cable length

150 cm (59 in)

Warning

Not rated for dust or gas / cannot be used in hazardous area

RS232 to USB cable (USBR)

Function

Connect to standard PC for configuration

Description

Made up of two cables that work together:
Standard DB9 female to female null modem RS232 cable
Standard male DB9 to full size type B female USB

Cable length

Null modem DB9 cable 305 cm (120 in)
DB9 to USB cable 45 cm (17.7 in)

Recommended software

Windows: PuTTY free open source terminal emulator
Mac OS X: Terminal built in terminal emulator

Warning

Not rated for dust or gas / cannot be used in hazardous area

Reflector (REFL)

Function

Reflective panel for positioning applications up to 150 m

Size

90 cm x 90 cm (36 in x 36 in)

Material

Aluminum with reflective paint

Cable glands (GCK)

Description

Set of 2 Ex cable glands with 1/2 in. NPT thread, size 0 / 8 mm and size 00 / 12 mm

Metric adaptor (GC1)

Description

Exd/e Flameproof imperial to metric adapter, 1/2 inch NPT to M20

Function

Enables use of metric M20 threaded conduits or cable glands with LM200

Demo Kit

Description

Rugged carrying case with LM200, dust tube and LCD2

Accessory dimensions

Dust tube (P801)

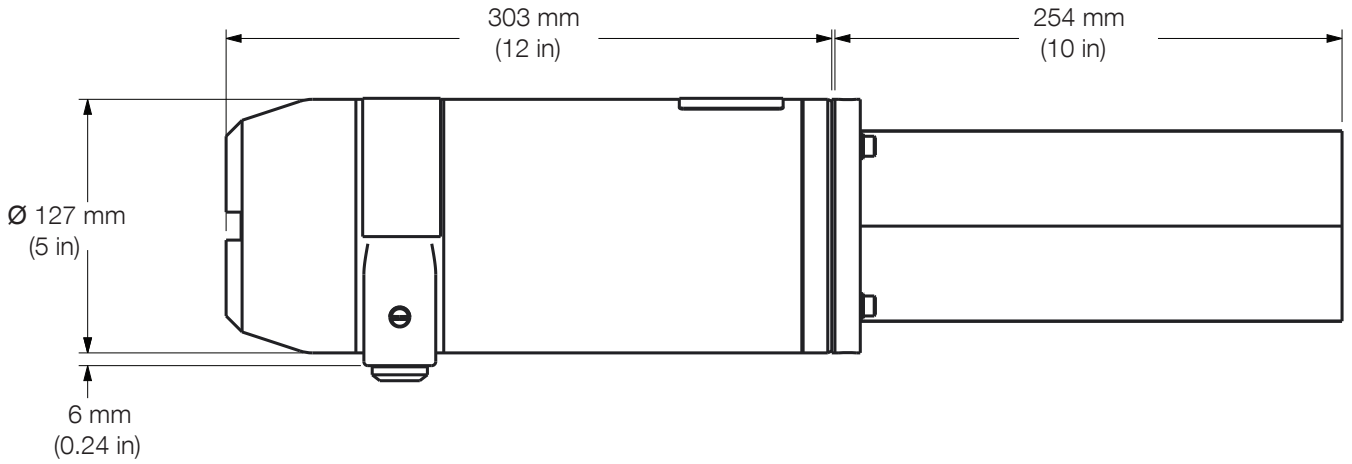

Figure 3 Dust tube (P801)

Mounting accessories

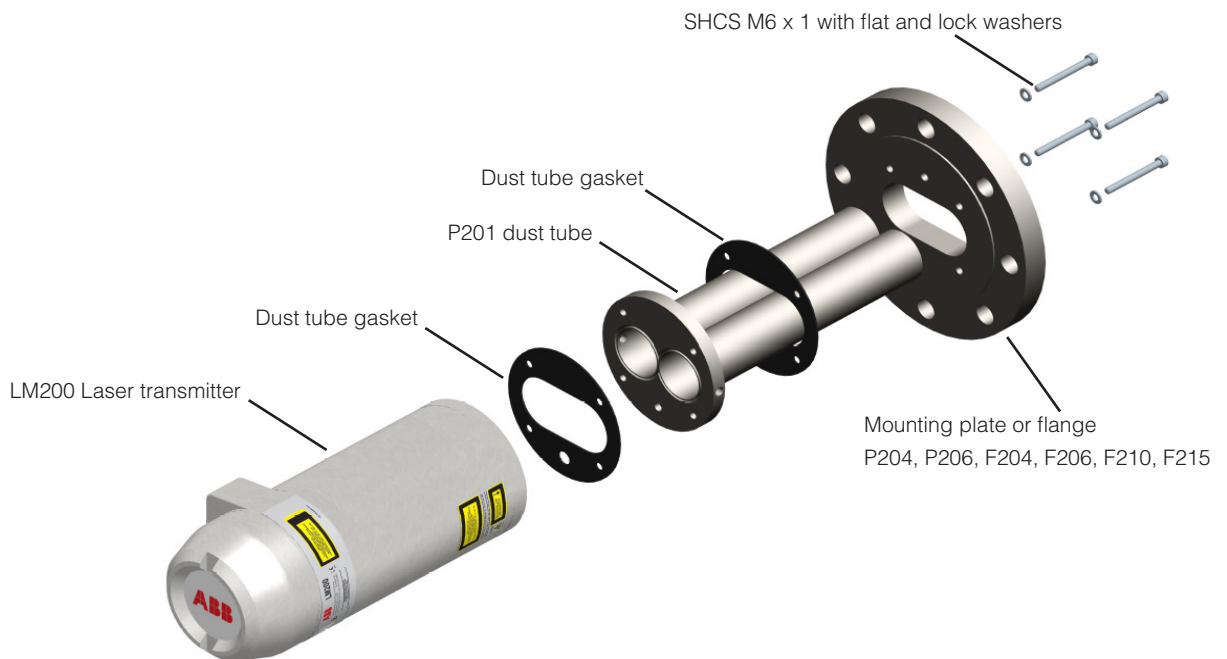

Figure 4 Mounting accessories

Accessory dimensions

4 inch/DIN 100 mounting plate (P204)

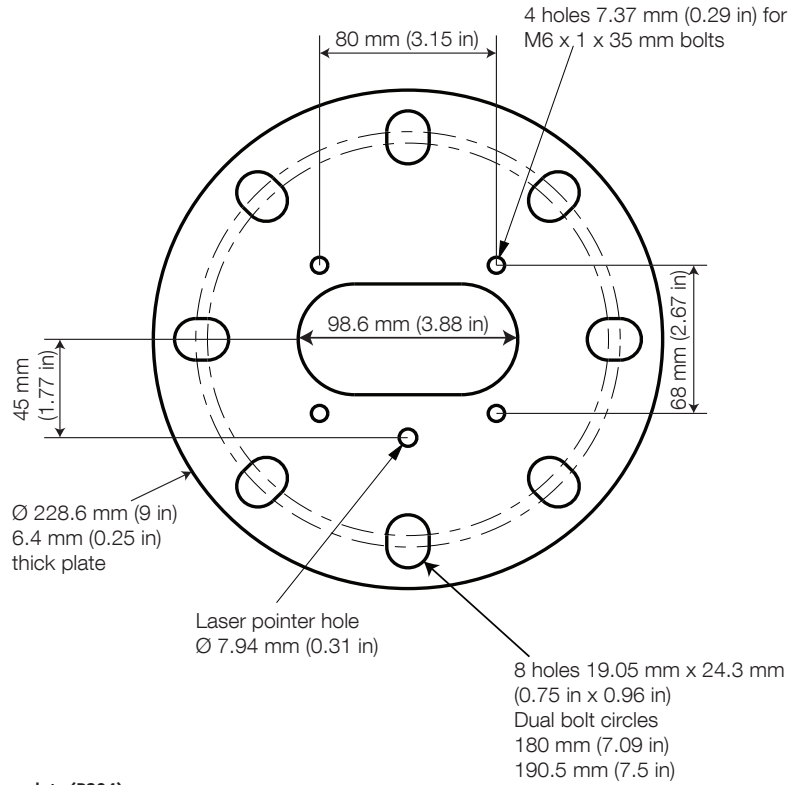

Figure 5 4 inch/DIN 100 mounting plate (P204)

6 inch/DIN 150 mounting plate (P206)

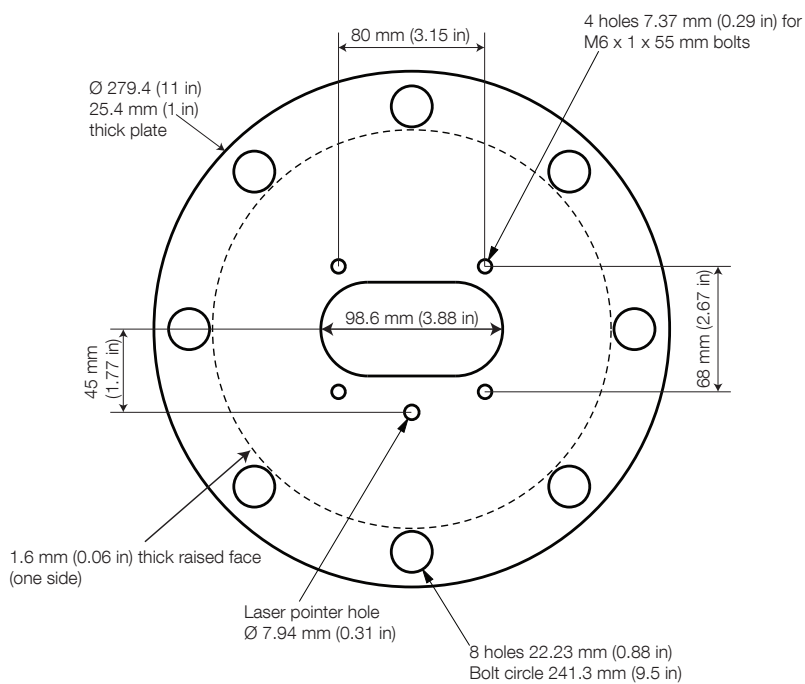

Figure 6 6 inch/DIN 150 mounting plate (P206)

Accessory dimensions

4 inch raised face mounting flange (F204)

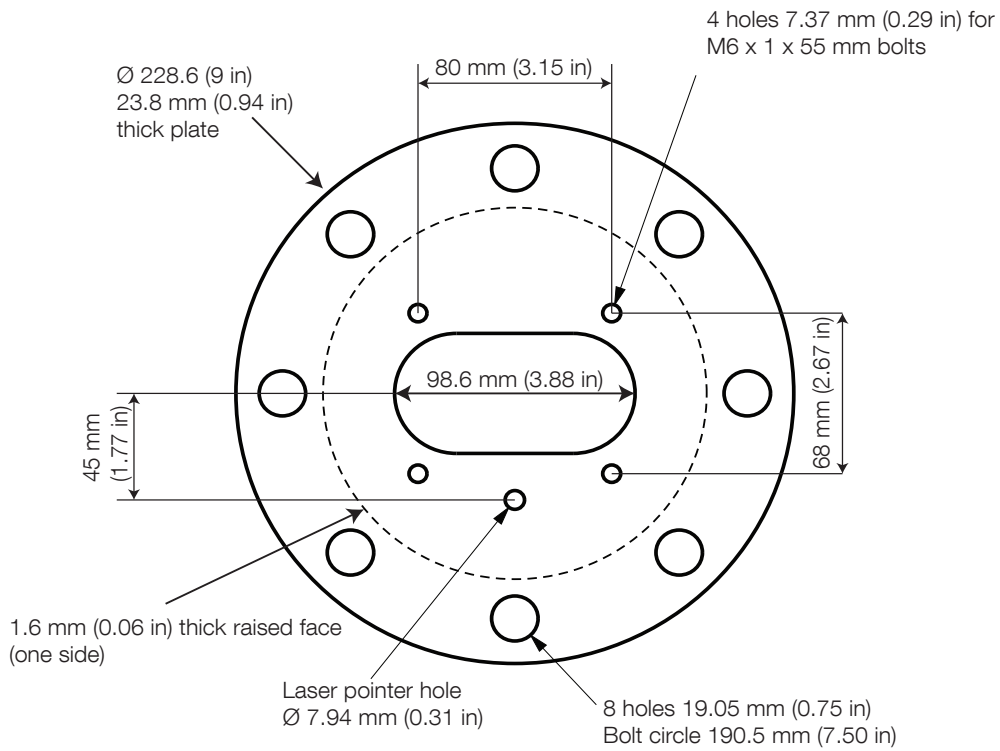

Figure 7 4 inch raised face mounting flange (F204)

6 inch raised face mounting flange (F206)

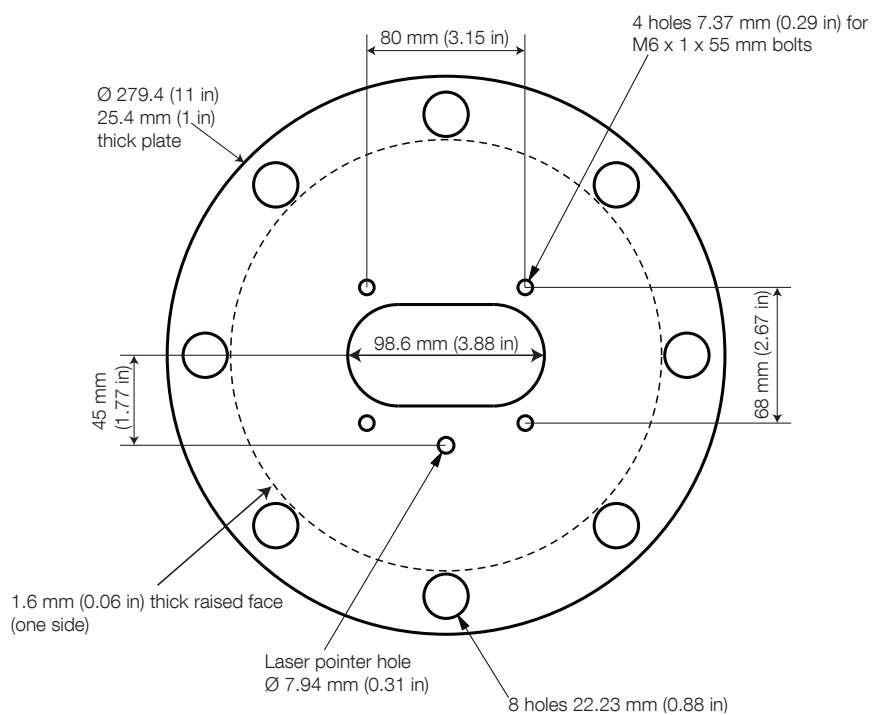

Figure 8 6 inch raised face mounting flange (F206)

Accessory dimensions

DIN 100 mounting flange (F210)

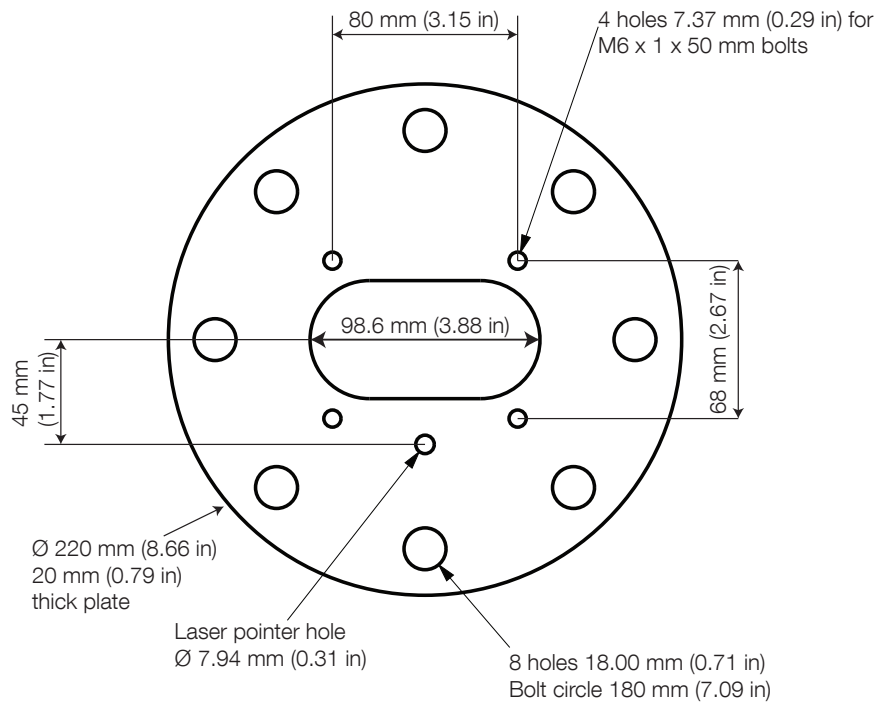

Figure 9 DIN 100 mounting flange (F210)

DIN 150 mounting flange (F215)

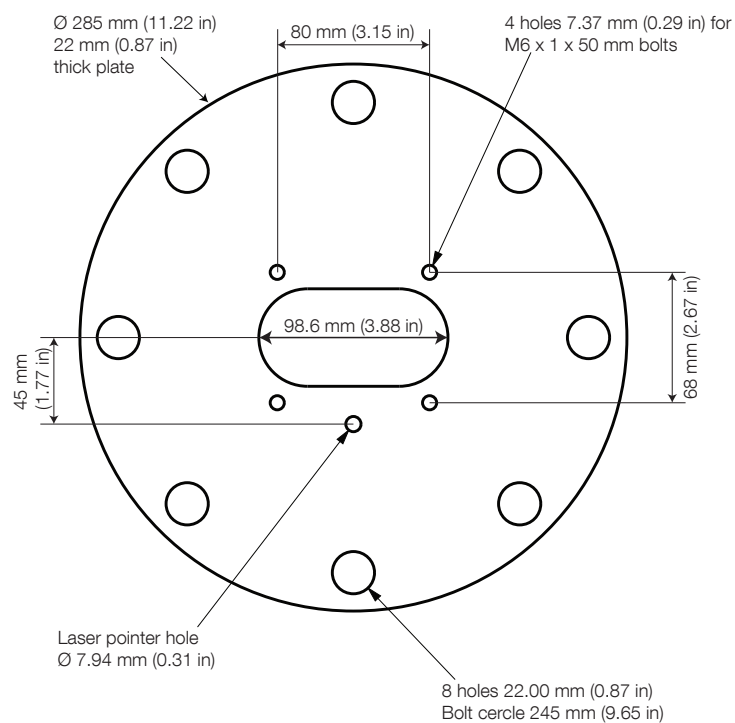

Figure 10 DIN 150 mounting flange (F215)

Accessory dimensions

Adjustable pivot bracket (A200)

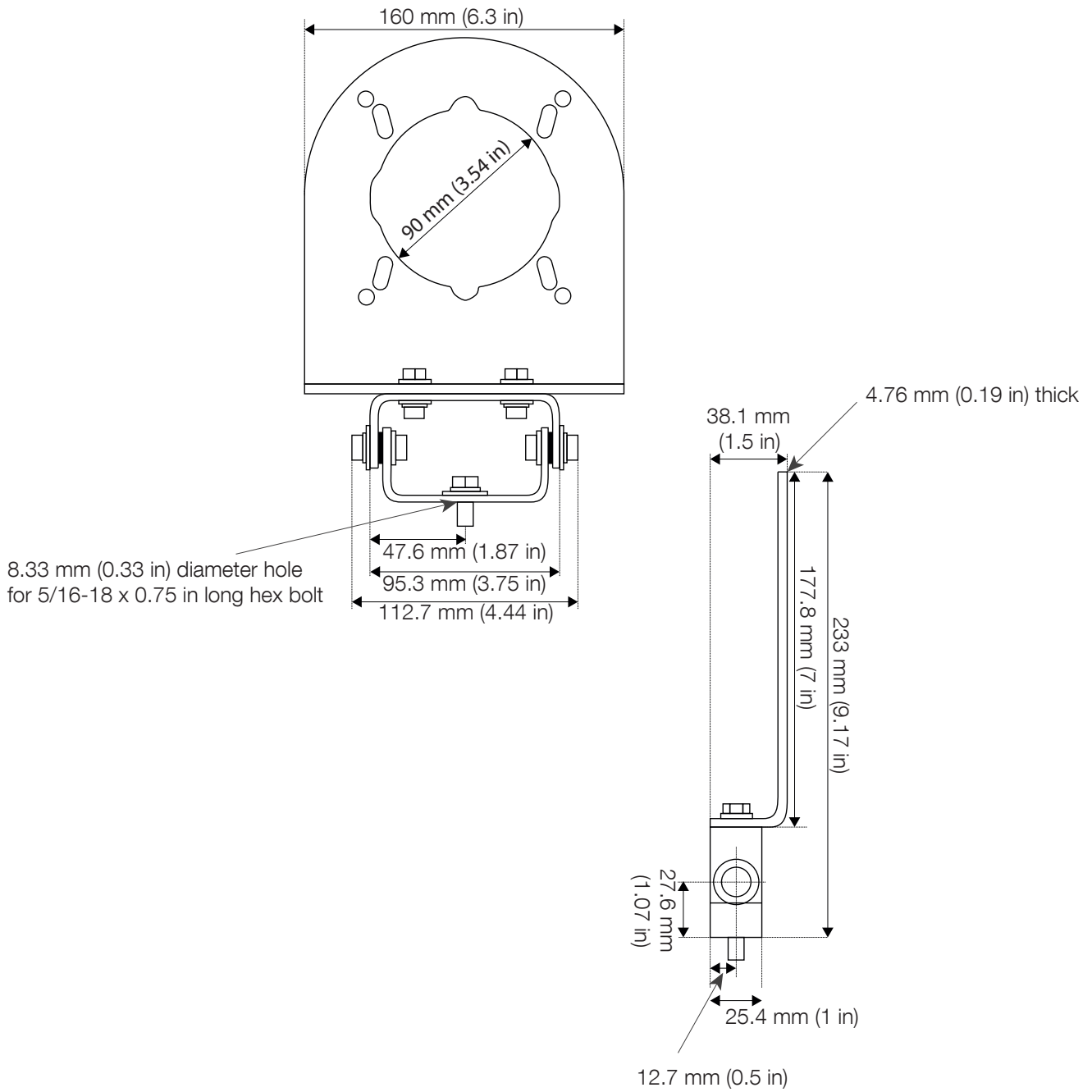

Figure 11 Adjustable pivot bracket (A200)

Miscellaneous accessories

Communication/configuration device and local display (LCD2)

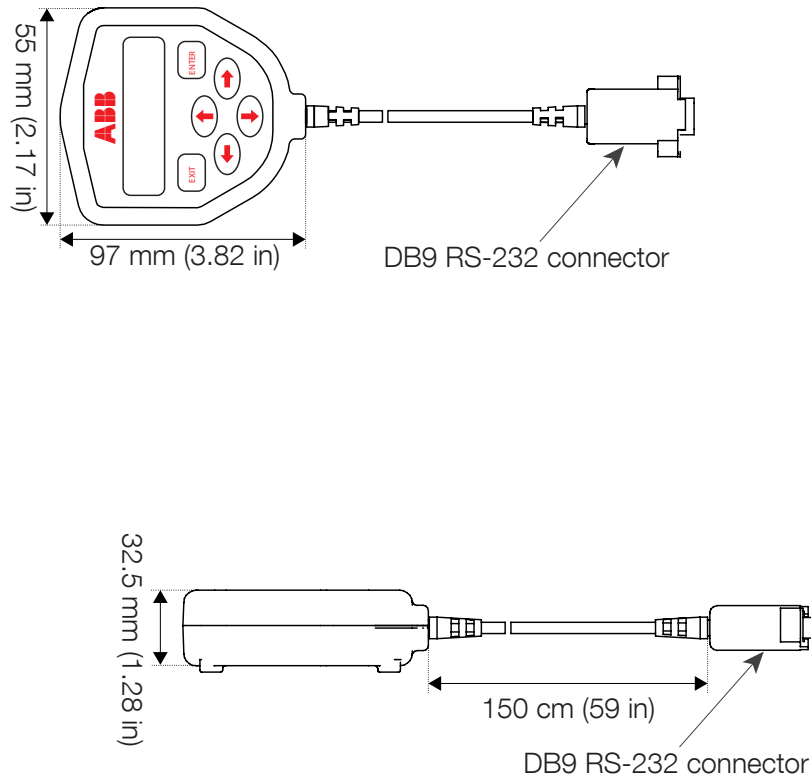

Figure 12 Communication/configuration device and local display (LCD2)

Miscellaneous accessories

RS232 to USB cable (USBR)

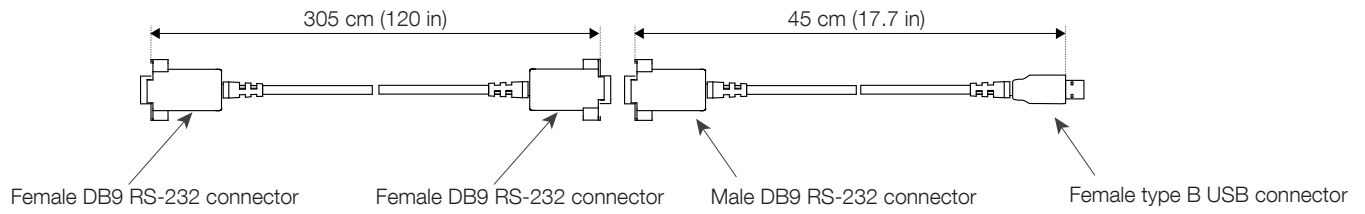

Figure 13 RS232 to USB cable (USBR)

Reflector (REFL)

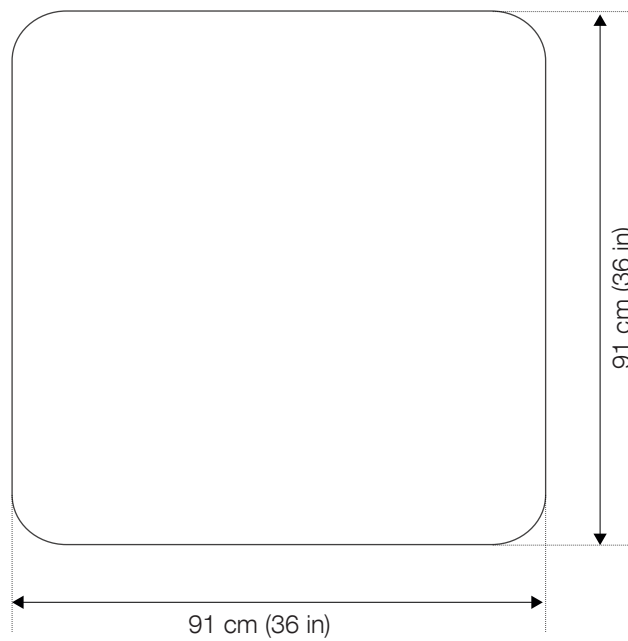

Figure 14 Reflector (REFL)

Ordering Information

Base model	LM200	A	B	C	D	E
Unit options						
Powder coated aluminum enclosure		A				
Powder coated aluminum enclosure with non-condensing optics		AC				
Powder coated aluminum enclosure with 304 stainless steel dust tube		AP201				
Power coated aluminum enclosure with non-condensing optics and stainless steel dust tube		ACP201				
Positioning unit 150 m (492 ft) range; includes dust tube, reflector and pivot mount		AP150				
Positioning unit 150 m (492 ft) range and non-condensing optics; includes dust tube, reflector and pivot mount		ACP150				
Positioning unit 250 m (820 ft) range; includes dust tube, reflector and pivot mount		AP250				
Positioning unit 250 m (820 ft) range and non-condensing optics; includes dust tube, reflector and pivot mount		ACP250				
Positioning unit 400 m (1312 ft) range; includes dust tube, reflector and pivot mount		AP400				
Positioning unit 400 m (1312 ft) range and non-condensing optics; includes dust tube, reflector and pivot mount		ACP400				
Approvals						
North America (Canada, USA) cCSAus Class 1 Div 2			CSA			
Factory Mutual FMus Class 1 Div 2			FM			
ATEX non sparking			ATEX			
IECEX non sparking			IECEX			
Metrology certification for Russia			RMET			
GOST-R non sparking and metrology certification for Russia			GR			
Extended warranty						
Extended warranty for 3 extra years - provides a total of 5 years warranty				EW		
Replacement warranty - provides customer with new replacement unit instead of repair				RW		
Accessories						
Stainless steel adjustable pivot mounting bracket					A200	
304 Stainless steel 4 in. / DN 100 mounting plate, bolt pattern as per class 150 and DN 100 / PN 10, no pressure rating					P204	
304 Stainless steel 6 in. / DN 150 mounting plate, bolt pattern as per class 150 and DN 150 / PN 10, no pressure rating					P206	
304 Stainless steel 4 in. raised face flange, bolt pattern as per class 150, no pressure rating					F204	
304 Stainless steel 6 in. raised face flange, bolt pattern as per class 150, no pressure rating					F206	
304 Stainless steel DN 100 flange, bolt pattern as per DN 100 / PN 10, no pressure rating					F210	
304 Stainless steel DN 150 flange, bolt pattern as per DN 150 / PN 10, no pressure rating					F215	
Communication/configuration device and local display						LCD2
RS232 to USB cable for configuring LM200 using laptop or desktop computer						USBR
Set of 2 Ex cable glands with 1/2 in. NPT thread; size 0 / 8 mm and size 00 / 12 mm						GCK
Exd/e Flameproof imperial to metric adapter, ½ inch NPT to M20						GC1
Reflector plate 36 in. x 36 in. / 90 cm x 90 cm, for positioning applications						REFL
Dust tube gaskets (set of 2) for LM200						G200

Software menu system



Software menu system

Communication with the LM200 takes place via the RS232 port located in the terminal compartment. Connect a computer with a standard USB port using the USBR cable and a terminal emulation programme such as PuTTY, or the handheld Communication Device (LCD2) directly to this port. Power up the LM200 and press the “EXIT” or “ENTER” button on the LCD2, or the PC’s “Spacebar” to enter the menu system.

The LM200 has advanced settings for more demanding applications. If the surface is unstable then the output can be smoothed by the rolling average “Buffer”. If material occasionally falls into the beam the erroneous result can be removed and the correct level maintained by using the “Keep” setting. If the LM200 is being used in a dusty environment the incorrect readings can be eliminated using the “Dust” settings.

There are controls for the visible pointer, for the maximum range, for offsets, test facilities for the 4–20 mA and relay outputs, a choice of Metric or Imperial measuring units and settings for fail-safe conditions based on the NAMUR standards.

Software menu item descriptions

Menu item	Values / Options	LCD2	Description
Running mode	Distance measured and 4–20 mA current output displayed.		
4–20 mA Settings	A group of settings and options related to the 4–20 mA analog output.		
4 mA setpoint	0.00 m (ft) to max range	Yes	Sets the distance at which the analog output reads 4 mA
20 mA setpoint	0.00 m (ft) to max range	Yes	Sets the distance at which the analog output reads 20 mA
Fail-safe output	3.6 mA, 21.00 mA, last mA reading	Yes	Select the fail-safe 4–20 mA analog value to be output if there is no signal
Safety time (Fail-safe delay)	0 sec to 450 sec	Yes	Enter the time that the signal is lost before the fail-safe condition is output
4–20 mA test	4.00 mA, 12.00 mA, 20.00 mA	Yes	Select a value to output on the analog channel for test purposes
4–20 mA trim	4 mA reading 20 mA reading	No	This function recalibrates the laser transmitter current output loop based on the readings entered at 4 mA and 20 mA
Relay settings	A group of settings and actions related to the relay outputs		
Relay A open	0.00 m (ft) to max range	Yes	Sets the distance at which the relay opens
Relay A closed	0.00 m (ft) to max range	Yes	Sets the distance at which the relay closes
Relay A test	open, closed	Yes	Toggles between relay open and relay closed
Relay B open	0.00 m (ft) to max range	Yes	Sets the distance at which the relay opens
Relay B closed	0.00 m (ft) to max range	Yes	Sets the distance at which the relay closes
Relay B test	open, closed	Yes	Toggles between relay open and relay closed
Application settings	A group of settings for filtering, smoothing and adjusting to application conditions		
Program	Standard, Light dust, Heavy dust, Position, Custom	Yes	Select predefined settings for selected application Use custom program for user defined application settings
Laser pointer	on off	No	Switch from service only mode (off - pointer comes on for 2 minutes at power up) to always on mode. All new LM200s are shipped set to off.
Range Blank	0.00 m (ft) to max range	No	If signal is lost this range is output instead of the fail safe setting
Resolution	High Low	No	High resolution is the normal setting, low resolution can be used for faster response at the expense of device resolution
Measuring units	meters, feet	Yes	Select measuring units; either meters or feet
Datum trim	–1.00 m (-3.28 ft) to 1.00 m (+3.28 ft)	Yes	Adjusts the zero datum point of the instrument. Factory default is from the front face of the flange (0.00 m).
Setpoint limit	0.00 m (ft) to ~400 m (~1400 ft)	No	Adjusts the maximum range of the device. The firmware allows up to 2980 m but the hardware is only capable of about 400 m (1400 ft).
Smoothing	Settings to adjust the filtering and smoothing of the output for the custom program		
Pause	0 sec to 255 sec	No	Sets the time between reading updates
Buffer	1 to 25	No	Sets the size of the rolling average buffer
Keep	1 to buffer	No	Sets the number of readings to keep in the averaging buffer, readings are removed starting with the shortest readings
Fill rate	0, 0.001 to 20000.000 units per minute	No	Sets the fastest filling speed expected, if zero the setting is not used. Otherwise, any sudden rise in level is smoothed by this setting.
Empty rate	0, 0.001 to 20000.000 units per minute	No	Sets the fastest emptying speed expected, if zero the setting is not used. Otherwise, any sudden drop in level is smoothed by this setting.
Environment	Normal Dust	No	“Normal” for most applications, uses fixed gain “Dust” uses variable gain to compensate for dusty conditions, is used in conjunction with fill rate

Red laser pointer

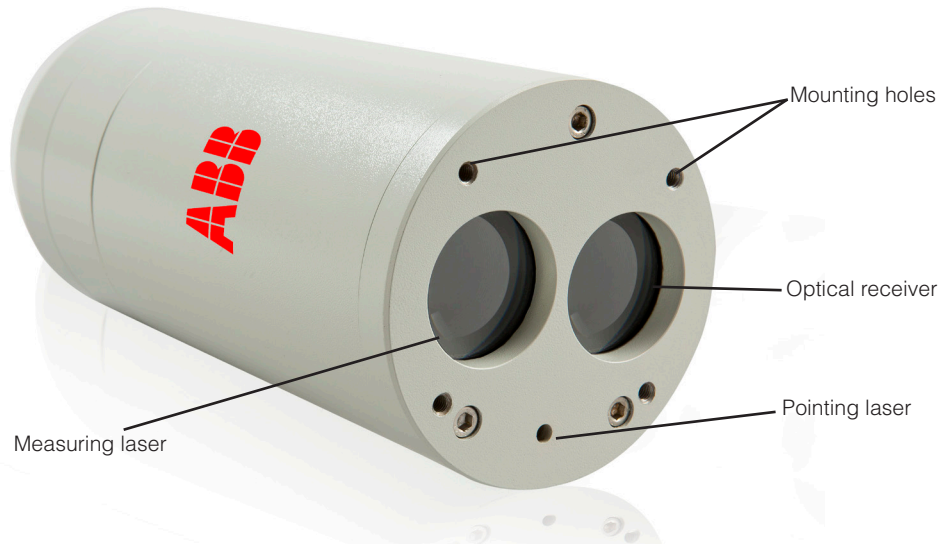

Red laser pointer

The LM200 includes a red laser pointer (Class 3R) that enables easy and accurate alignment. Through the menu system, the pointer can be set to “On” or “Off”. When set to “Off” the pointer will shine for 2 minutes at power on and when the unit is in the menu system. It is possible to change the behavior at power on using the advanced menus so that the laser pointer never shines except when in the menu system. When set to “On”, the pointer will shine continuously when in the menu system and flash when the unit is taking measurements. The LM200 always ships from the factory with the pointer set to “Off”.

Mounting

The LM200 produces a narrow, straight measuring laser beam. The unit should be mounted facing towards the area to be measured with no obstacles directly in the beam path. Avoid mounting the instrument close to a stream of material that may fall in front of it. The LM200 has four diameter mounting holes to be bolted directly onto a flange or bracket with 4 M6 screws. The LM200 may receive stronger signals in subdued lighting and dark conditions than it does in direct sunlight. Check the operation over the full range of conditions to be measured after installing.

Grounding

It is recommended to use a AWG 16 or 1.5 mm² wire for earth connection. For best results use a size 10 earth lug with a copper body terminal per ASTM B-152, and tin plating per MIL-T-10727, and a manufacturer AMP part No. 34112 or No. 34109. The earth wire terminated with the recommended earth lug must be connected to the designated terminal for this purpose. The internal and the external earth screws are made of stainless steel.

Cables, wiring and routing

Always use shielded cables for power supply and signal. It is recommended to use a AWG16 or 1.5 mm² multi-core cable. The number of cores will depend upon the outputs required from the LM200. For a 4–20mA output, use a twisted pair shielded cable. Do not install the LM200 or route the signal cables in close proximity to high voltage electrical cables.

Dust management

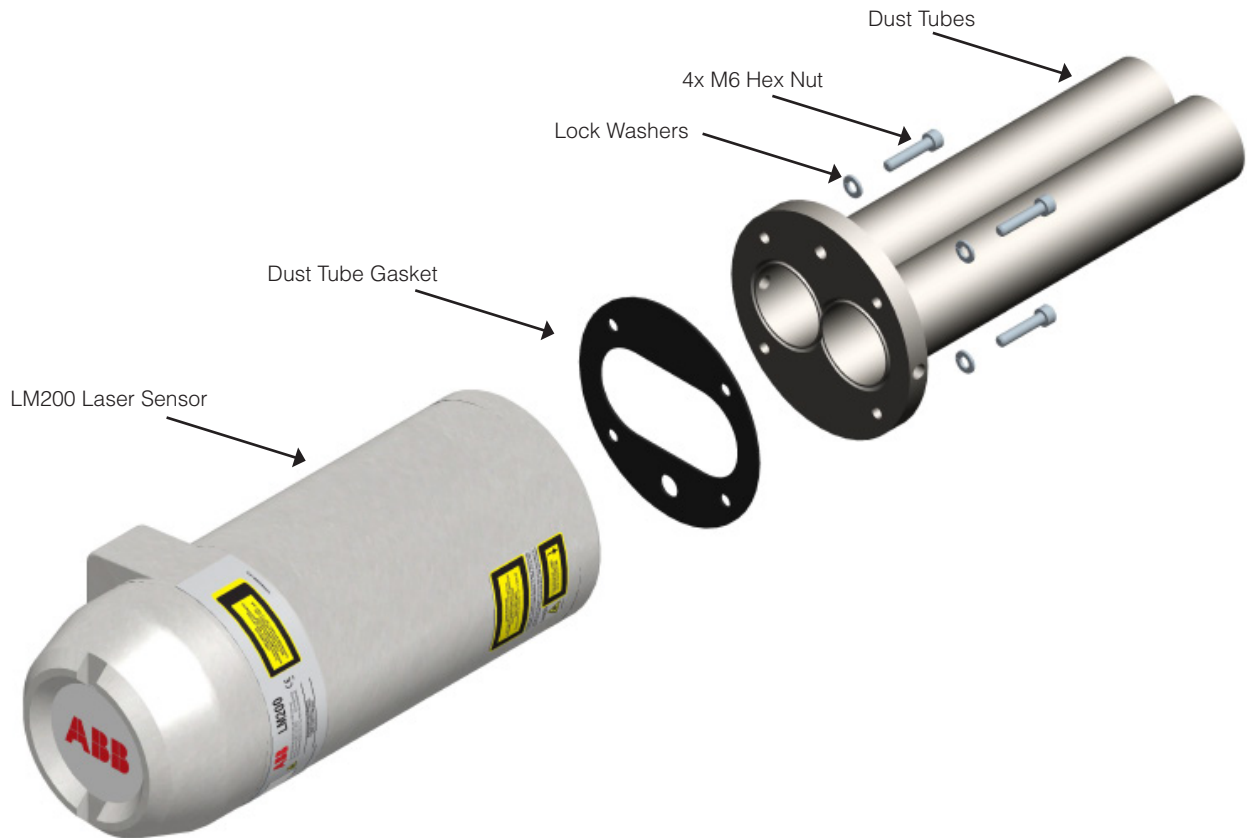

Dust management

In applications where dust may be present (even in very small quantities) it is recommended that the P201 dust tube accessory be used. The LM200 has a 1/8 NPT fitting for dust management. The dust tube is a simple and effective device, designed to prevent dust settling on the lenses by creating a static airspace. When abundant dust is present the dust tube can additionally be purged with dry oil free air to further reduce any dust settling on the lens.

There are a number of advanced settings to improve performance when dust is present. The “Dust” setting in the “Environment” menu increases the dust penetration capabilities of the laser. In applications where the vessel may be loaded in batches and intermittent clouds of dust appear, a “Fill rate” may be entered to slow down the rate of response of the instrument.

Standard precautions

The LM200 is designed to withstand many industrial environmental conditions. However, a few precautions will ensure reliable operation of the unit for extended periods of time:

- Do not drop the instrument.
- Do not open the terminal compartment lid when an explosive dust or gas atmosphere may be present.
- Do not connect to the RS232 port when an explosive dust or gas atmosphere may be present.
- Do not expose the internal electronics to water or dirt.
- Do not install or connect with the power on.
- Use appropriate insulated lugs or ferrules for connections to the terminal block and grounding screws.
- The flat stainless steel washer must be incorporated between the enclosure body and the lug to prevent corrosion from occurring.
- External transient protection of up to 40 % (44 V) of the maximum supply voltage ($32 \text{ V} \times 1.4 \leq 44 \text{ V}$) should be incorporated in the power supply line to the equipment when used in hazardous areas.
- Always keep the terminal compartment lid seal clean and lightly lubricated with Vaseline® Petroleum Jelly.
- Ensure that the terminal compartment lid is tight after connections have been made.
- If using cable glands, only use glands that have been suitably certified by a notified body for cable entry into the enclosure. If in doubt use cable glands supplied by ABB.
- Ensure that the cable glands are tight after connecting the external cable.
- Do not install conduit so that it can drain into the LM200 terminal compartment.
- Remove dirt from the lenses with a clean, damp cloth only.
- Do not point the instrument at the sun.
- Avoid aiming the LM200 directly into the fill path of the vessel.
- For liquids always mount the laser to aim perpendicular to the liquid surface.

ABB, Inc.**Measurement & Analytics**

3400, rue Pierre-Ardouin
Québec (Québec) G1P 0B2
Canada

Phone:

North America: 1 800 858 3847
Worldwide: +1 418 877 8111

E-mail:

level.support@ca.abb.com

www.abb.com/laserlevel

www.youtube.com/abbmeasurementexpert











3KXL312001R1001

We reserve the right to make technical changes or modify the contents of this document without prior notice. With regard to purchase orders, the agreed particulars shall prevail. ABB does not accept any responsibility whatsoever for potential errors or possible lack of information in this document.

We reserve all rights in this document and in the subject matter and illustrations contained therein. Any reproduction, disclosure to third parties or utilization of its contents – in whole or in part – is forbidden without prior written consent from ABB.
©ABB, 2022



Our offering:

	Actuators and Positioners		Analytical Instruments
	Device Management, Fieldbus and Wireless		Flow Measurement
	Force Measurement		Level Measurement
	Natural Gas Measurement		Pressure Measurement
	Recorders and Controllers		Temperature Measurement

HMI – Automação e Instrumentação, Lda.

Travessa da Indústria, nº 111
4780-573 Santo Tirso
PORTUGAL

Tel. +351 252 850 501
Fax. +351 300 013 487

Web: www.hmi.pt

Email: hmi@hmi.pt