



hmi

high-accuracy
measurement
instruments

FICHA TÉCNICA DE PRODUTO

PRODUCT DATASHEET

HMI – Automação e Instrumentação, Lda.

Travessa da Indústria, nº 111
4780-573 Santo Tirso
PORTUGAL

Tel. +351 252 850 501
Fax. +351 300 013 487

Web: www.hmi.pt

Email: hmi@hmi.pt

ABB MEASUREMENT AND ANALYTICS | DATA SHEET

KM26

Magnetic level gauge

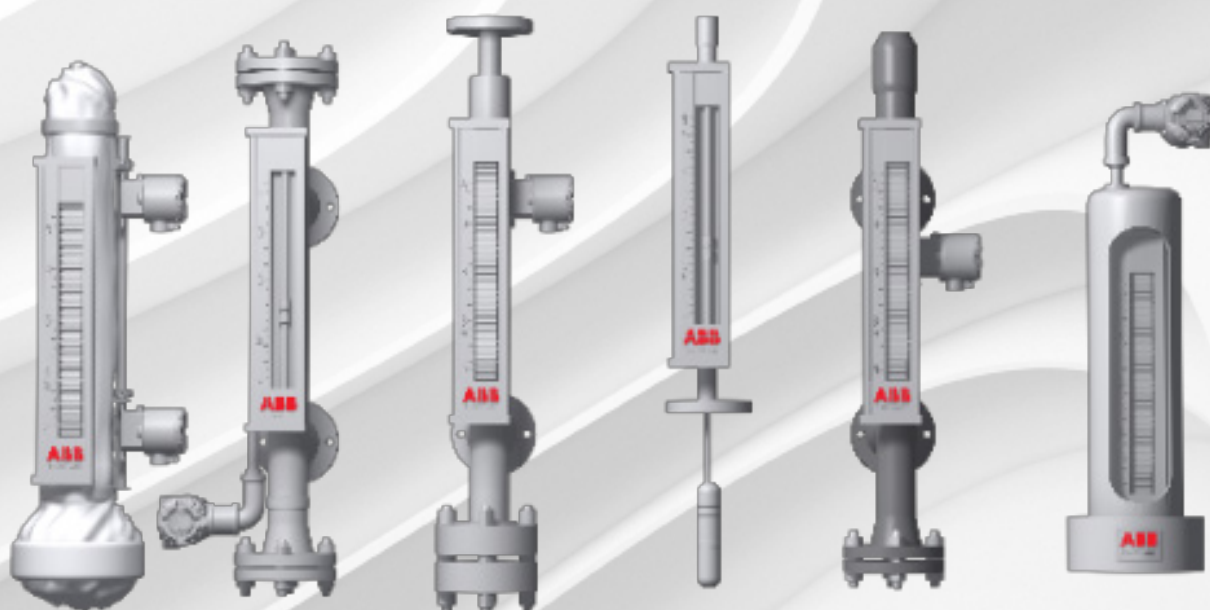

Measurement made easy

Innovative level measurement solutions

Features

- highly visible level indication with no process fluid in contact with the glass
- all construction in-house by code certified welders
- float designed and weighted for maximum accuracy with 75 grams minimum upward buoyant force
- transmitter and switch options which can be installed, adjusted and maintained with no process interruption
- safe for corrosive, flammable, toxic, high-temperature and high-pressure applications
- rugged design – low or no maintenance

Available materials

- Stainless steel—304/304L, 316/316L, 317/317L, 321, 347
- Alloy 20
- C-276
- Alloy 600, 625, 800, 825
- Titanium
- Teflon® (registered trademark of DuPont) coated stainless steel
- PVC, CPVC
- Zirconium
- Monel
- For other materials consult factory

Process capabilities

- full vacuum to 5000 PSI / 345 BAR
- -320 to 1000 °F/ -196 to 538 °C
- 0.25 specific gravity
- all liquid viscosities
- interfaces as low as .03 ΔSG

Testing and documentation available upon request

- radiographic examination
- liquid dye penetrant examination
- hydrostatic examination
- PMI (positive material identification) material certification
- ASME “U,” “UM,” or “S” stamp
- third party inspection
- material certificates
- ANSI/ASME B31.1, B31.3
- PED certification
- NACE MR0103, NACE MR0175
- Canadian registration number (CRN)
- mechanical function test
- float curves (total level only)
- ATEX C- constructional safety with non-exotic materials construction
- IP68 visual indicator (scale assembly)

Selecting the KM26

Selecting the appropriate KM26 configuration for a specific application is important. Use these questions to determine your requirements.

What is the process fluid?

- specific gravity
- operating / design temperature
- operating / design pressure
- total, interface or dual-level detection

What are the gauge body details?

- material of construction
- maximum pressure & temperature requirement
- necessary level range (liquid level fluctuation; often the vessel height)
- vent and drain connections (will I be piping into the MLG or adding valves?)

What are the process connection details?

- size
- type
- rating
- orientation/position

What style of indicator is preferred?

- flag (orange/black, yellow/black, red/white, custom colors)
- shuttle (also known as follower or birdie) – high visibility

What measuring scale is required?

- level (inches, feet, meters)
- volume (gallons, liters, custom)
- percent

What accessories are necessary?

- switch (point-level)
- level transmitter; what communication protocol?
- frost extension (prevents ice build-up from blocking a direct view to the indicator)
- heat tracing (electric or steam)
- insulation: high-temp (fiberglass) or low-temp (cryogenic foam)
- magnetic particle traps
- gauge glass

Installation considerations

- lengths over 12 feet: support brackets to minimize pipe flex
- lengths over 20 feet: sectionalize (flanged) or one continuous section (welded)
- structural support types: Gussets or welded support brackets

Overview

Helping to keep worldwide infrastructure at a safe level, day-in and day-out

Key features



Engineered to order



No electric power



Integrate transmitters, switches & accessories



Adaptable solution



Non-invasive magnetic indicator

Installation and service



No field calibration



5 year warranty

Fast and easy



Easy start-up and low maintenance



Fully factory assembled with all quality reports

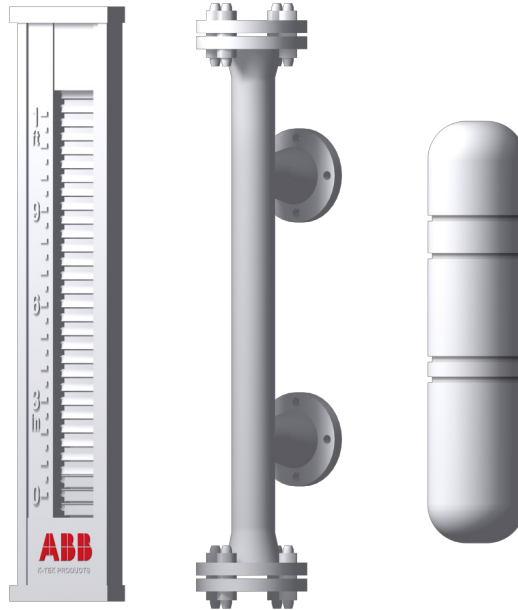

Industrial design and world class manufacturing



NDE, PMI, NACE tests



ASME U, UM, S stamping



Wide range of applications: oil and gas, petrochem, chemical, power and more



Wide environmental and process conditions



RoHS 2.0



ATEX



PED

CRN



IP 68



-196°C to 537°C



Up to 345 bar / 5000 psi

...Overview

KM26 magnetic level gauge

Advantages for you

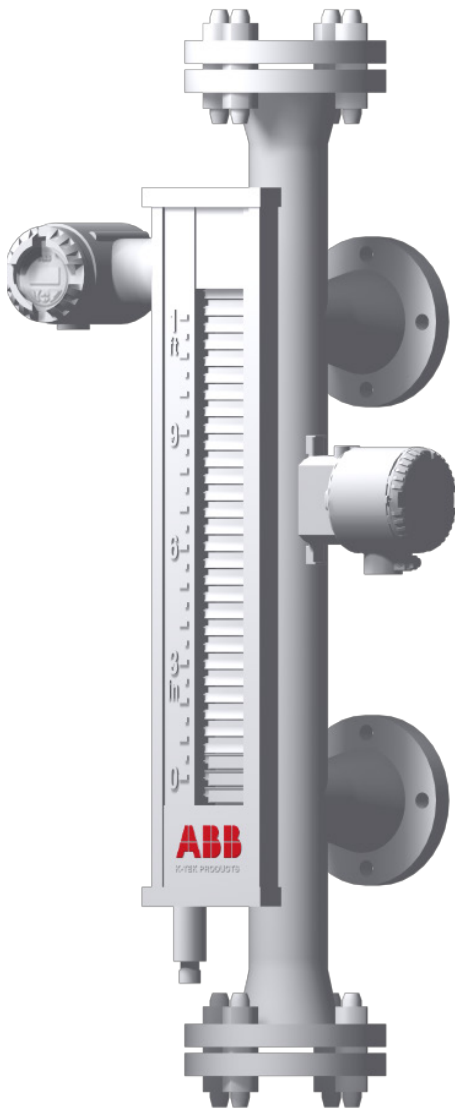

Full fabrication, assembly and accessories installed, tested and calibrated and shipped from factory results in lower cost of ownership



No piping modifications or process interruptions to add transmitters and switches to a KM26 results in lower cost of ownership



Superior float design results in increased accuracy of level measurement increasing the energy efficiency and throughput.



Easy blow down or flush of chamber, no disassembly required; minimum spare parts requirements resulting in increase in productivity



Fewer potential leak points, no hazardous liquids in the indicator; no glass under high pressure or temperature



...Overview

Industry leader for safe and reliable level measurement– your benefits at a glance

A robust design

Custom engineered to the process application (length, pressure, temperature, and specific gravity), ASME, PED, ATEX, CRN, IP68, RoHS compliance, no segments therefore much less piping & field fabrication, no torquing or re-torquing of cover bolts to stop leaks, much easier start-up

Communication without interruption

Increased safety as the transmitters, switches and hermetically sealed scale assembly mounted externally communicates reliably with the strong magnetic float inside the chamber

Reduce

Total cost of ownership, no recalibration, minimize maintenance

Safety

No potential leak points for fugitive emissions and glass not under high pressure or temperature

Modular and intuitive design

Flexibility and a tailored solution with on-site upgrade of transmitters and switches

Reliable performance

Superior visibility with the bar graph indicators

Non-invasive

Scale assembly, transmitters and switches are added/adjusted without pipe modification or process interruptions

A solution for every application

all KM26's shipped fully assembled and tested with all accessories

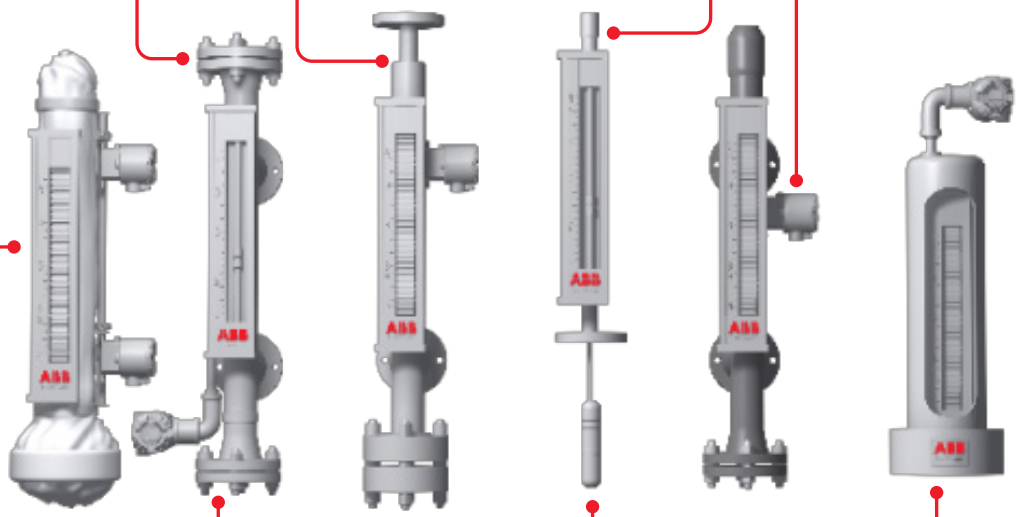

...Ordering information

Mandatory characteristics	KM26S	XXX	XXX	XX	XX	XX	XX	XX	XX	XX	XX	XX	XXXX	XX	XX
Refer to previous page															
Indicator scale / ruler															
No indicator channel (must select 'X' for indicator type)														X	
SS channel; no scale														A	
SS channel; SS scale marked in ft / inches with ½ in. divisions (from 0 to 50 ft. standard ^{11,12})														B	
SS channel; SS scale marked in meters/centimeters with 1 cm divisions ^{9,11,12}														C	
SS channel; SS scale marked in running inches with ½ in. divisions ^{10,11,12}														D	
SS channel; SS scale marked in running inches with ⅜ in. divisions ^{10,11,12}														E	
SS channel; custom SS scale (% , gallons, liters, etc.); provide details of custom scale separate from model #.														F	
SS indicator channel; one "B" type (feet / inches) standard scale (from 0 to 50 ft, standard) ¹² and one custom SS scale														BS	
SS indicator channel; one "C" type (meters / centimeters) standard scale ^{9,12} and one custom SS scale														CS	
SS indicator channel; one "D" type (running inches with ½ in divisions) standard scale ^{10,12} and one custom SS scale														DS	
SS indicator channel; one "B" type (running inches with ⅜ in divisions) standard scale ^{10,12} and one custom SS scale														ES	
SS indicator channel; Two custom SS scales														FS	
Custom														Z9	
Approvals															
No approvals															X
ATEX, construction safety															U4

Notes:

- 1 If no side connection is required, put an 'X' in the model # as a placeholder
- 2 'Z9' shall be specified for sizes and ratings not listed in table 3.
- 3 'X' shall be specified for B0, D0, S0, SW0, T0 and W0 code options.
- 4 Only a size designation (no rating) shall be specified for B1, B1H, B10, B10H, D1, D1H, D10, D10H, L1, L1H, SW1, SW1H, SW10, SW10H, W1, W10, W1E, and W1S code options.
- 5 Add 'IH' as an "additional ordering code" to include insulation pad behind the indicator to increase the temperature rating to 350 °F / 177 °C.
- 6 Add 'IHT' as an "additional ordering code" to include insulation pad and TEMP-COAT® behind the indicator and transmitter / switch if (applicable) to increase the MBG temperature rating to 1000 °F / 538 °C. (The 'IHT' option is not used when chamber insulation with TEMP-COAT® ordering codes IH2T, IH2DT, IH3T and IH3DT are selected.)
- 7 Add 'D' as a suffix to the indicator type when dual level indication (total and interface) is required.
- 8 Add 'F' as a suffix to the indicator type when "float failure" indication is required.
- 9 Standard rulers begin with 0 cm but can be specified from -100 cm to 10 meters.
- 10 Standard rulers begin with 0 inches but can be specified from: ½ in. divisions: -48 in. to 216 in. OR ⅜ in. divisions: -48 in. to 144 in.
- 11 Custom rulers available (consult factory – choose F)
- 12 Scale / ruler is positioned to the left of the indicator tube (when facing the indicator.)

...Ordering information

Additional ordering codes

Special

Anything not included in the below additional ordering codes will be considered a special and designated as such with a "Z99". This includes any side process connections over the standard quantity of 3. Z99

Heat / electric tracing

Steam trace tubing	TT1
Steam / water jacket	SJ
Electric tracing; Class I, Div. 2, Gp BCD; (221 °F/(105 °C) max; fixed setpoint control ^{2,5}	ET1xx
Electric tracing; Class I, Div. 2, Gp BCD; (400 °F/(204 °C) max; adjustable setpoint control ^{2,5}	ET2x
Electric tracing; Class I, Div. 1, Gp CD; 800 °F / (427 °C) max; adjustable setpoint control ^{2,5}	ET3

Valves

Vent valve (specify valve manufacturer and model)	VV
Isolation valve (specify valve manufacturer and model)	IV
Drain valve (specify valve manufacturer and model)	DV

Other

Switch mount rod (high temperature option for KM26 switches)	RD
Gussets on process connections (SCH 40 minimum chamber recommended)	G
Oversized chamber with guide rods for flashing	GR
Adjustable support bracket	ASB

Insulation

High temperature insulation pad ¹	IH
High temperature insulation pad with Temp-Coat (See note 6 under "indicator type") ^{1,4}	IHT
High temperature insulation; float chamber only; (250 °F/121 °C) max ¹	IH1
High temperature insulation; float chamber and vent / drain flanges; (250 °F/121 °C) max ¹	IH1D
High temperature insulation; float chamber only; (500 °F/260 °C) max ¹	IH2
High temperature insulation; float chamber and vent / drain Flanges; (500 °F/260 °C) max ¹	IH2D
High temperature insulation; float chamber only; (1000 °F/538 °C) max ^{1,3}	IH2T
High temperature insulation; float chamber and vent / drain flanges; (1000 °F/538 °C) max ^{1,3}	IH2DT
High temperature insulation; float chamber only; (1000 °F/538 °C) max ^{1,6}	IH3
High temperature insulation; float chamber and vent / drain flanges; (1000 °F/538 °C) max ^{1,3,6}	IH3D
High temperature insulation; float chamber only; (1000 °F/538 °C) max ^{1,3,6}	IH3T
High temperature insulation; float chamber and vent / drain flanges; (1000 °F/538 °C) max ^{1,3,6}	IH3DT
Cryogenic insulation; 2 in. Thick; single layer; (350 °F/177 °C) max; (-100 °F/-73 °C) minimum	IL1
Cryogenic insulation; 3" thick; double layer; (350 °F/177 °C) max; (-200 °F/-129 °C) minimum	IL2
Cryogenic insulation; 4" thick; double layer; (350 °F/177 °C) max; (-320 °F/-196 °C) minimum	IL3

Notes:

- 1 ABB recommends chamber insulation for personnel safety.
- 2 Specify power supply 1) 110, 2) 220, or 3) 440 VAC; (ex. ET21 with 110 VAC power supply). For ET1xx series only, specify setpoint A) 35°, B) 45°, C) 60°, D) 90° or E) 185 °F (1.7°, 7.2°, 15.6°, 32.2°, or 85 °C) (ex. ET11A = ET1 with 110VAC power supply and a setpoint of 35 °F).
- 3 This option is only used when a MBG indicator type is selected AND the maximum temperature exceeds 650 °F/343 °C.
- 4 This insulation option is not allowed with shuttle indicators (S3P, S3G).
- 5 This option is not allowed with U4 approval code for ATEX constructional safety.
- 6 This option can not be used with transmitters or switches as this insulation is thicker than IH1 and IH2 options.

...Ordering information

Note: The following accessories/services selected will not appear in the model # on engineering drawings or nameplates.

Engineering documents	
Drawings for approval	GD1
Drawings for record	GD2
Certified as built drawings	GD3
Weld map (per tag)	GD4
Inspection and test plan	GD5
Float curve	GD6
Special	
Radiographic examination on all pressure containing butt welds / and all other pressure containing welds are liquid dye penetrant tested (final pass only)	CRA
Radiographic examination on all pressure containing butt welds / and all other pressure containing welds are liquid dye penetrant tested (root and final Pass)	CRB
10% Radiographic examination on pressure containing butt welds / 10% of other pressure containing welds are liquid dye penetrant tested (final pass only)	CRC
10% Radiographic examination on pressure containing butt welds / 10% of other pressure containing welds are liquid dye penetrant tested (root and final pass)	CRD
Radiographic examination on all pressure containing butt welds (final pass only)	CRE
Radiographic examination on all pressure containing welds (root and final pass)	CRF
Liquid dye penetrant – per tag	
Liquid dye penetrant examination on all pressure containing welds (final pass only)	CNA
Liquid dye penetrant examination on all pressure containing welds (root and final pass)	CNB
Liquid dye penetrant examination on 10% of all pressure containing welds (final pass only)	CNC
Liquid dye penetrant examination on 10% of all pressure containing welds (root and final pass)	CND
Liquid dye penetrant examination on all welds (final pass only)	CNE
Positive material identification	
Positive material identification with carbon content (PMI without carbon to be done on items not functionally accessible to PMI equipment)	CHC
Positive material identification without carbon content	CHD
Pressure equipment directive (PED)*†	
Pressure equipment directive certificate of compliance (SEP), RoHS compliance**	K6
Pressure equipment directive declaration of conformity (category I – IV), RoHS compliance**	K8
Hydrostatic examination	
Hydrostatic examination – (10 minutes)	CP1
Hydrostatic examination with chart recording – (30 minutes)	CP2
Hydrostatic examination with chart recording – (60 minutes)	CP3
Hydrostatic examination with chart recording – (120 minutes)	CP4
Hydrostatic examination of float	CP5
Additional Services	
RoHS compliance, no PED**	K5
Ultrasonic testing – thickness testing	CH6
Ultrasonic testing – shearwave	CHS
Magnetic particle inspection / testing	CH5
Painting with standard ABB K-TEK paint (carbon steel non-wetted surfaces only)	STP
Special painting or surface treatment per customer specification	STS
Post weld heat treatment	CH7
Equipment weight documentation	GW1
Hardness testing (per customer specification)	CHV
Intergranular corrosion destructive test CHA	
Corrosive test	CHB
Charpy test	CHE
Certificate of surface finish	CHF
Certificate of pickling and passivation	CHP

* Requires C2 or C3 in material monitoring

** RoHS compliance–restricted materials like cadmium plated items not allowed

† Requires CP1, CP2, CP3, or CP4 in hydrostatic examination (10 minute minimum).

...Ordering information

Note: The following accessories/services selected will not appear in the model # on engineering drawings or nameplates.

ASME code stamp*†	
ASME code stamp U	CSU
ASME code stamp UM	CSM
ASME code stamp S	CSS
Material monitoring	
Material monitoring with inspection certificate 3.1 acc. EN 10204 (MTR)	C2
Material monitoring with inspection certificate 3.2 acc. EN 10204 (MTR)	C3
Manufacturer's Data Records	
ABB standard manufacturer's data records indexed (all requested testing, drawings, certificates, etc.) as a single document and electronically transferred with no customer approvals required	CD1
Special manufacturer's data records, indexed	CDZ
Origin documents	
Certificate of origin	GS1
Certificate of origin notarized by local chamber of commerce	GS2
Certificate of origin legalized by specific country chamber of commerce – lead time may be extended depending on country	GS3
Korean foreign trade certificate	GS4
NAFTA certificate	GS5
EX-IM BANK certificate (one per tag)	GS6
Approved material list*	
Country of origin – material source limitations apply	MS1
Approved material list	GS7
Welding options	
Full penetration welds only	FWP
No flux core arc welding (FCAW) allowed	FWT
Certifications	
Certificate of compliance for ANSI / ASME*†	CK
General certificate of compliance	CL
Certificate of functionality (mechanical function test)	CU3
Canadian registration number*†	CRN
Calibration certificate of hydrotest equipment†	CPE
NACE	
NACE (MR 0103) hardness certificate*	CN1
NACE (MR 0175 / ISO 15156) hardness certificate*	CN3

*Requires C2 or C3 in material monitoring

†Requires CP1, CP2, CP3, or CP4 in hydrostatic examination

...Ordering information

Table 1

Chamber / connection material	
321 SS	SS1
304 / 304L SS	SS4
316 / 316L SS	SS6
317 / 317L SS	SS7
347 SS	S47
Hastelloy® C-276	HSC
Titanium (Grade 2) (600 °F / 316 °C Max)	TI
PVC (140 °F / 60 °C Max) ^{3,10}	PVC
CPVC (210 °F / 99 °C Max) ^{3,10}	CPV
Teflon® "S" One Coat Coated 304 / 304L SS ^{1,5,11}	TN4
Teflon® "S" One Coat Coated 316 / 316L SS ^{4,5,11}	TN6
Halar® Coated 304 / 304L SS ^{2,4,6,11}	HL4
Halar® Coated 316 / 316L SS ^{2,4,6,11}	HL6
Tefzel® Coated 304 / 304L SS (-150 °F / -101 °C Min) ^{2,4,6,7,11}	TF4
Tefzel® Coated 316 / 316L SS(-150 °F / -101 °C Min) ^{2,4,6,7,11}	TF6
Alloy 20 (800 °F / 427 °C Max)	A20
Alloy 600	I60
Alloy 625	I62
Alloy 800	I80
Alloy 825	I82
Zirconium 702 (700 °F / 371 °C Max)	ZI2
Monel® 400 (900 °F / 482 °C Max)	MO
Carbon Steel (-20 °F / -29 °C Min) ⁹	CST
Low Temperature Carbon Steel (-50 °F / -46 °C min.) ⁹	LCS
Duplex® Stainless Steel (600 °F / 316 °C max.) ⁹	DUP
Other material type (specify separately)	Z9

- 1 To minimize friction for optimal float travel – maximum temperature = 425 °F (218 °C).
 - 2 For increased corrosion resistance – maximum temperature = 300 °F (149 °C).
 - 3 Maximum measuring length is 18 ft. (5.48 m).
 - 4 Tefzel® or Halar® coated units must not have any FNPT options and must have chamber sized flanged access on top and bottom of chamber. This option should not be used on connections that require welding in the field.
 - 5 Maximum measuring length 22 ft. (6.7 m).
 - 6 Maximum measuring length 16 ft. (4.88 m).
 - 7 Schedule 40 minimum chamber required.
 - 8 Maximum measuring length = 15 ft. (4.57 m).
 - 9 Not available as a chamber option. When CST, LCS and DUP materials are chosen, all parts which are not welded directly to the side of the chamber can be of those same material types.
 - 10 This is not available as a chamber, connection, or float material with U4 approval code for ATEX constructional safety.
 - 11 When the chamber material selected is a coated option, the connection materials will also have that same coating type applied.
- * TEFLON®, Tefzel®, Alloy® (registered trademark of Dupont)
 * Hastelloy® (registered trade mark of Haynes International, Inc.)
 * Halar® (registered trademark of Solvay Solexis)
 * Monel® (registered trademark of the INCO)
 * Duplex® (registered trademark of Leupold and Stevens, Inc.)
 * TEMP-COAT® (Registered trademark of Southern Professional Leasing Inc. DBA Span-World Distribution Corporation)

Required dimensional information (specify in inches or mm):

ML, CF, FF, CC and FC dimensions.

Note: When 3 or more side connections are required, specify the distance between each connection.

Important note:

The information above is provided for the customer to indicate specific requirements. Other sizing and ratings not specified will be selected by the factory based on standard design and manufacturing practices using temperature, pressure and specific gravity data.

...Ordering information

Table 2

Definitions	Code options
Blind Flange with Float Stop Spring and Mating Slip-On Flange	B0
B0 with FNPT ³	B1
B0 with Plug ³	B2
B0 with Socket Weld Half Coupling ³	B3
B0 with FNPT Half Coupling ³	B4
B0 with Pipe Nipple, for Socket Welding (Flat) ³	B5
B0 with Pipe Nipple, for Butt Welding (37.5° bevel) ³	B6
B0 with Pipe Nipple, MNPT ³	B7
B0 with Pipe Nipple and Slip-On Flange ³	B9S
B0 with Pipe Nipple and Weld Neck Flange ³	B9W
B0 with Socket Weld Bore ³	B10
B0 with Flat Sock-o-let ³	B3L
B0 with Flat Thread-o-let ³	B4L
B0 with Flat Sock-o-let, Pipe Nipple for Socket Welding (Flat) ³	B5L
B0 with Flat Sock-o-let, Pipe Nipple for Butt Welding (37.5° Bevel) ³	B6L
B0 with Flat Sock-o-let and Pipe Nipple, MNPT ³	B7L
B0 with Flat Sock-o-let, Pipe Nipple and Slip-On Flange ³	B9SL
B0 with Flat Sock-o-let, Pipe Nipple and Weld Neck Flange ³	B9WL
B0 with Pipe Nipple and Socket Weld Coupling ³	B3C
B0 with Pipe Nipple and SW x FNPT Coupling ³	B4C
B0 with Flat Sock-o-let, Pipe Nipple and Socket Weld Coupling ³	B3LC
B0 with Flat Sock-o-let, Pipe Nipple and SW x FNPT Coupling ³	B4LC
B0 with FNPT Half Coupling and Plug ³	B4P
B0 with Flat Thread-o-let and Plug ³	B4LP
B0 with Pipe Nipple, SW x FNPT Coupling and Plug ³	B4CP
B0 with Flat Sock-o-let, Pipe Nipple, SW x FNPT Coupling and Plug ³	B4LCP
FNPT Half Coupling	C0
C0 with Plug	C0P
Thread-o-let (Min. SCH 40 Chamber)	C0L
SW x FNPT Coupling with Pipe Nipple	C0C
SW x FNPT Coupling with Pipe Nipple connected via Extruded Outlet ²	COCE
Socket Weld Half Coupling	C1
Socket Weld Coupling with Pipe Nipple	C1C
Socket Weld Coupling with Pipe Nipple connected via Extruded Outlet ²	C1CE
SW x FNPT Coupling with Pipe Nipple and Sock-o-let (Min. SCH 40 Chamber)	COLC
Sock-o-let (Min. SCH 40 Chamber)	C1L
Socket Weld Coupling with Pipe Nipple and Sock-o-let (Min. SCH 40 Chamber)	C1LC

...Ordering information

Table 2 (continued)

Definitions	Code options
Blind Flange with Float Stop Spring and a Mating Weld Neck Flange	D0
D0 with FNPT ³	D1
D0 with Plug ³	D2
D0 with Socket Weld Half Coupling ³	D3
D0 with FNPT Half Coupling ³	D4
D0 with Pipe Nipple, for Socket Welding (Flat) ³	D5
D0 with Pipe Nipple, for Butt Welding (37.5° Bevel) ³	D6
D0 with Pipe Nipple, MNPT ³	D7
D0 with Pipe Nipple and Slip-On Flange ³	D9S
D0 with Pipe Nipple and Weld Neck Flange ³	D9W
D0 with Socket Weld Bore ³	D10
D0 with Flat Sock-o-let ³	D3L
D0 with Flat Thread-o-let ³	D4L
D0 with Flat Sock-o-let and Nipple, for Socket Welding (Flat) ³	D5L
D0 with Flat Weld-o-let and Nipple, for Butt Welding (37.5° Bevel) ³	D6L
D0 with Flat Weld-o-let and Nipple, MNPT ³	D7L
D0 with Flat Weld-o-let, Pipe Nipple and Weld Neck Flange ³	D9L
D0 with Pipe Nipple and Socket Weld Coupling ³	D3C
D0 with Pipe Nipple and SW x FNPT Coupling ³	D4C
D0 with Flat Weld-o-let, Pipe Nipple and Socket Weld Coupling ³	D3LC
D0 with Flat Weld-o-let, Pipe Nipple and SW x FNPT Coupling ³	D4LC
D0 with FNPT Half Coupling and Plug ³	D4P
D0 with Flat Thread-o-let and Plug ³	D4LP
D0 with Pipe Nipple, SW x FNPT Coupling and Plug ³	D4CP
D0 with Flat Weld-o-let, Pipe Nipple, SW x FNPT Coupling and Plug ³	D4LCP
Weld Neck Flange with Float Stop Spring (Top/Bottom Code Option) ¹	F
Weld Neck Flange connected to chamber via Extruded Outlet ²	FE
Weld Neck Flange with Pipe Nipple (Side Code Option)	F0
FE with Pipe Nipple Between Chamber and Weld Neck Flange ²	F0E
Weld Neck Flange with Weld-o-let (Min. SCH 40 Chamber)	F1
Weld Neck Flange with Weld-o-let and Pipe Nipple (Min. SCH 40 Chamber)	F1C
Weld Neck Flange with Weld-o-let and Concentric Reducer (Min. SCH 40 Chamber)	F2
Weld Neck Flange with Weld-o-let and Concentric Reducer and Pipe Nipple (Min. SCH 40 Chamber)	F2C
Weld Neck Flange with Concentric Reducer	F3
Weld Neck Flange with Concentric Reducer connected to chamber via Extruded Outlet ²	F3E
Weld Neck Flange with Concentric Reducer and Pipe Nipple	F3C
Weld Neck Flange with Concentric Reducer and Pipe Nipple connected via Extruded Outlet ²	F3CE
Weld Neck Flange with Butt Weld Tee	F4
Weld Neck Flange with Butt Weld Tee and Pipe Nipple	F4C
Weld Neck Flange with Butt Weld Tee and Concentric Reducer	F43
Weld Neck Flange with Butt Weld Tee and Concentric Reducer and Pipe Nipple	F43C
Weld Neck Flange with Concentric Reducer (Top/Bottom Code Option)	F9

...Ordering information

Table 2 (continued)

Definitions	Code options
Slip-On Flange with Float Stop Spring (Top/Bottom Code Option) ¹	G
Slip-On Flange with Pipe Nipple connected to chamber via Extruded Outlet ²	GE
Slip-On Flange with Pipe Nipple (Side Code Option)	G0
Slip-On Flange with Weld-o-let and Pipe Nipple (Min. SCH 40 Chamber)	G1
Slip-On Flange with Weld-o-let, Concentric Reducer and Pipe Nipple	G2
Slip-On Flange with Concentric Reducer and Pipe Nipple	G3
Slip-On Flange with Concentric Reducer and Pipe Nipple Connected via Extruded Outlet ²	G3E
Slip-On Flange with Butt Weld Tee and Pipe Nipple	G4
Slip-On Flange with Butt Weld-tee, Concentric Reducer and Pipe Nipple	G43
Stub End with Lap Joint Flange with Float Stop Spring (Top/Bottom Code Option) ¹	L
Stub End with Lap Joint Flange (Side Code Option)	L0
Stub End with Lap Joint Flange connected to chamber via Extruded Outlet ²	LE
Stub end with Lap Joint Flange and Pipe Nipple connected via Extruded Outlet ²	LCE
L with Mating Blind Flange with FNPT ³	L1
L with Mating Blind Flange with Plug ³	L2
Stub end with Lap Joint Flange and Pipe Nipple	LC
Stub end with Lap Joint Flange and Concentric Reducer	L3
Stub end with Lap Joint Flange, Concentric Reducer connected via Extruded Outlet ²	L3E
Stub end with Lap Joint Flange, Concentric Reducer and Pipe Nipple	L3C
Stub end with Lap Joint Flange, Concentric Reducer and Pipe Nipple connected via Extruded Outlet ²	L3CE
L with Mating Stub End and Lap Joint Flange, Concentric Reducer, Stub End and Lap Joint Flange	L39
Stub End with Lap Joint Flange and Butt Weld Tee	L4
Stub End with Lap Joint Flange, Butt Weld Tee and Concentric Reducer	L43
L with Mating Blind Flange, Pipe Nipple, Stub End and Lap Joint Flange ³	L9
Branch Nipple, for Socket Weld (Flat)	N0
Branch Nipple, for Socket Weld (Flat) connected to chamber via Extruded Outlet ²	N0E
Branch Nipple, for Butt Welding (37.5° Bevel)	N2
Branch Nipple, for Butt Welding (37.5° Bevel) connected to chamber via Extruded Outlet ²	N2E
MNPT Branch Nipple	N3
MNPT Branch Nipple connected to chamber via Extruded Outlet ²	N3E
Weld-o-let, for Butt Welding (Min. SCH 40 Chamber)	N6
Weld-o-let with Pipe Nipple, for Socket Weld (Flat) (Min. SCH 40 Chamber)	N0L
Weld-o-let with Pipe Nipple, for Butt Welding (37.5° Bevel) (Min. SCH 40 Chamber)	N2L
Weld-o-let with Pipe Nipple, MNPT, (Min. SCH 40 Chamber)	N3L
Weld Neck Flange with Mating Weld Neck Flange, Float Stop Spring, Concentric Reducer and Weld Neck Flange	R9

...Ordering information

Table 2 (continued)

Definitions	Code options
Screwed Pipe Cap with Float Stop Spring (Min. SCH 40 Chamber)	S0
S0 with FNPT Half Coupling (Min. SCH 40 Chamber)	S4
S0 with FNPT Half Coupling and Plug (Min. SCH 40 Chamber)	S4P
S0 with Pipe Nipple, MNPT	S7
Socket Weld Flange with Float Stop Spring (Top/Bottom Code Option) ¹	SW
Blind Flange with Float Stop Spring and Mating Socket Weld Flange	SW0
SW0 with FNPT ³	SW1
SW0 with Plug ³	SW2
SW0 with Socket Weld Half Coupling ³	SW3
SW0 with FNPT Half Coupling ³	SW4
SW0 with Nipple, for Socket Welding (Flat) ³	SW5
SW0 with Nipple, for Butt Welding (37.5° bevel) ³	SW6
SW0 with Pipe Nipple, MNPT ³	SW7
SW0 with Pipe Nipple and Socket Weld Flange ³	SW9
SW0 with Socket Weld Bore ³	SW10
SW0 with Flat Sock-o-let ³	SW3L
SW0 with Flat Thread-o-let ³	SW4L
SW0 with Flat Sock-o-let, Pipe Nipple for Socket Welding (Flat) ³	SW5L
SW0 with Flat Sock-o-let, Pipe Nipple for Butt Welding (37.5° bevel) ³	SW6L
SW0 with Flat Sock-o-let and Pipe Nipple, MNPT ³	SW7L
SW0 with Flat Sock-o-let, Pipe Nipple and Socket Weld Flange ³	SW9L
SW0 with Pipe Nipple and Socket Weld Coupling ³	SW3C
SW0 with Pipe Nipple and SW x FNPT Coupling ³	SW4C
SW0 with Flat Sock-o-let, Pipe Nipple and Socket Weld Coupling ³	SW3LC
SW0 with Flat Sock-o-let, Pipe Nipple and SW x FNPT Coupling ³	SW4LC
SW0 with FNPT Half Coupling and Plug ³	SW4P
SW0 with Flat Thread-o-let and Plug ³	SW4LP
SW0 with Pipe Nipple, SW x FNPT Coupling and Plug ³	SW4CP
SW0 with Flat Sock-o-let, Pipe Nipple, SW x FNPT Coupling and Plug ³	SW4LCP
Socket Weld Flange with Pipe Nipple	SWS
Socket Weld Flange with Pipe Nipple connected to chamber via Extruded Outlet ²	SWSE
Socket Weld Flange with Weld-o-let and Pipe Nipple	SWS1
Socket Weld Flange with Weld-o-let, Concentric Reducer and Pipe Nipple	SWS2
Socket Weld Flange with Concentric Reducer and Pipe Nipple	SWS3
Socket Weld Flange with Concentric Reducer and Pipe Nipple connected via Extruded Outlet	SWS3E
Socket Weld Flange with Butt Weld Tee and Pipe Nipple	SWS4
Socket Weld Flange with Butt Weld Tee, Concentric Reducer and Pipe Nipple	SWS43

...Ordering information

Table 2 (continued)

Definitions	Code options
Butt Welded Pipe Cap with Float Stop Spring	T0
T0 with Socket Weld Half Coupling	T3
T0 with FNPT Half Coupling	T4
T0 with Pipe Nipple, for Socket Welding (Flat)	T5
T0 with Pipe Nipple, for Butt Welding (37.5° Bevel)	T6
T0 with Pipe Nipple, MNPT	T7
T0 with Pipe Nipple and Slip-On Flange	T9S
T0 with Pipe Nipple and Socket Weld Flange	T9SW
T0 with Pipe Nipple and Weld Neck Flange	T9W
T0 with Flat Sock-o-let	T3L
T0 with Flat Thread-o-let	T4L
T0 with FNPT Half Coupling and Plug	T4P
T0 with Flat Thread-o-let and Plug	T4LP
T0 with Flat Weld-o-let and Pipe Nipple, for Socket Welding (Flat)	T5L
T0 with Flat Weld-o-let and Pipe Nipple, for Butt Welding (37.5° Bevel)	T6L
T0 with Flat Weld-o-let and Pipe Nipple, MNPT	T7L
T0 with Flat Weld-o-let, Pipe Nipple and Slip-On Flange	T9SL
T0 with Flat Weld-o-let, Pipe Nipple and Weld Neck Flange	T9WL
T0 with Flat Weld-o-let, Pipe Nipple and Socket Weld Flange	T9SWL
T0 with Pipe Nipple and Socket Weld Coupling	T3C
T0 with Pipe Nipple and SW x FNPT Coupling	T4C
T0 with Flat Weld-o-let, Pipe Nipple and Socket Weld Coupling	T3LC
T0 with Flat Weld-o-let, Pipe Nipple and SW x FNPT Coupling	T4LC
T0 with Pipe Nipple, SW x FNPT Coupling and Plug	T4CP
T0 with Flat Weld-o-let, Pipe Nipple, SW x FNPT Coupling and Plug	T4LCP

...Ordering information

Table 2 (continued)

Definitions	Code options
Welded Flat End Cap with Float Stop Spring	W0
W0 with FNPT	W1
W0 with Plug	W2
W0 with Socket Weld Half Coupling	W3
W0 with FNPT Half Coupling	W4
W0 with Pipe Nipple, for Socket Welding (Flat)	W5
W0 with Pipe Nipple, for Butt Welding (37.5° Bevel)	W6
W0 with Pipe Nipple, MNPT	W7
W0 with Pipe Nipple and Slip-On Flange	W9S
W0 with Pipe Nipple and Socket Weld Flange	W9SW
W0 with Pipe Nipple and Weld Neck Flange	W9W
W0 with Socket Weld Bore	W10
W0 with Flat Weld-o-let	W3L
W0 with Flat Thread-o-let	W4L
W0 with Flat Weld-o-let and Pipe Nipple for Socket Welding (Flat)	W5L
W0 with Flat Weld-o-let and Pipe Nipple for Butt Welding (37.5° Bevel)	W6L
W0 with Flat Weld-o-let and Pipe Nipple, MNPT	W7L
W0 with Flat Weld-o-let, Pipe Nipple and Slip-On Flange	W9SL
W0 with Flat Weld-o-let, Pipe Nipple and Weld Neck Flange	W9WL
W0 with Flat Weld-o-let, Pipe Nipple and Socket Weld Flange	W9SWL
W0 with Pipe Nipple and Socket Weld Coupling	W3C
W0 with Pipe Nipple and SW x FNPT Coupling	W4C
W0 with Flat Weld-o-let, Pipe Nipple and Socket Weld Coupling	W3LC
W0 with Flat Weld-o-let, Pipe Nipple and SW x FNPT Coupling	W4LC
W0 with Flat Thread-o-let and Plug	W4LP
W0 with Pipe Nipple, SW x FNPT Coupling and Plug	W4CP
W0 with Flat Weld-o-let, Pipe Nipple, SW x FNPT Coupling and Plug	W4LCP
Branch Nipple with Flat End Cap with FNPT, connected via Extruded Outlet ²	W1E
Branch Nipple with Flat End Cap with FNPT, connected via Saddle Weld	W1S
No connection	X
Custom	Z9

Notes:

- When a flanged option (F, G, L, SW) is a process connection on either end of the chamber as shown in the configuration tables these will be provided with a float stop bar (or disk) and spring to keep the float confined in the chamber.
- Extruded outlet connections can be utilized as follows:

	Chamber schedule	Flange/pipe sizes
*Stainless steel:	10	1 in., 1-½ in. and 2 in.
*Stainless steel:	40	1-½ in. and 2 in.
Alloy 20:	10	1-½ in. and 2 in.
Hastelloy® C-276:	10	1-½ in. and 2 in.

*Includes SS1, SS4, SS6, SS7, S47, TN4, TN6, HL4, HL6, TF4 and TF6 material types. TF4 and TF6 types require SCH 40 minimum chambers. Welded or seamless chambers can be extruded. Extruded outlets are full bore up to a maximum of 2 in. NPS.

- Add an 'H' behind the code option if a high hub blind flange is required. In those same cases where a 'P' is added in the model code for plugged options, the 'H' shall be placed in front of the 'P'.

Chamber configuration – top

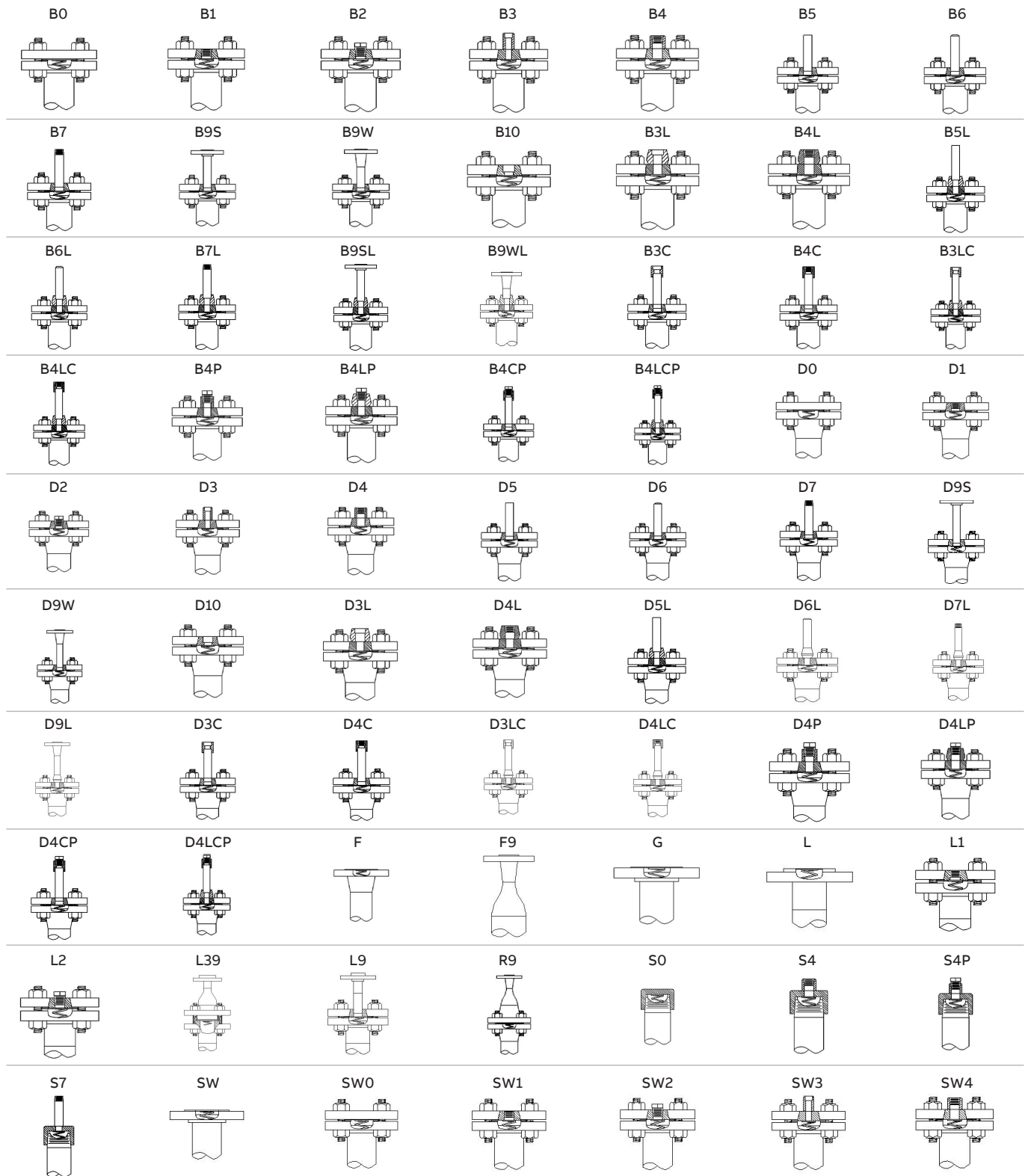

Figure1 Chamber configuration – top

...Chamber configuration – top

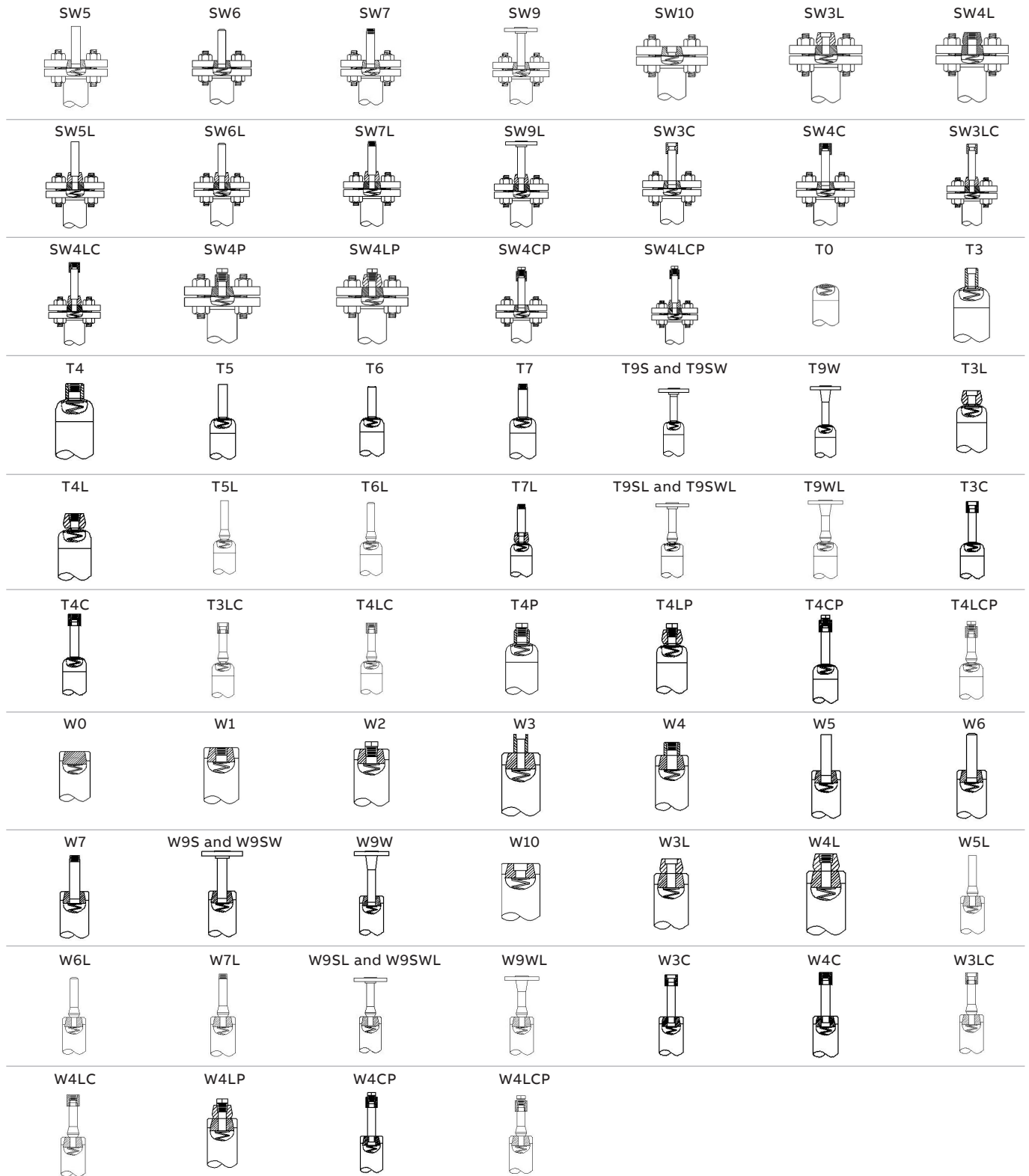

Figure1 Chamber configuration – top (continued)

Chamber configuration – side

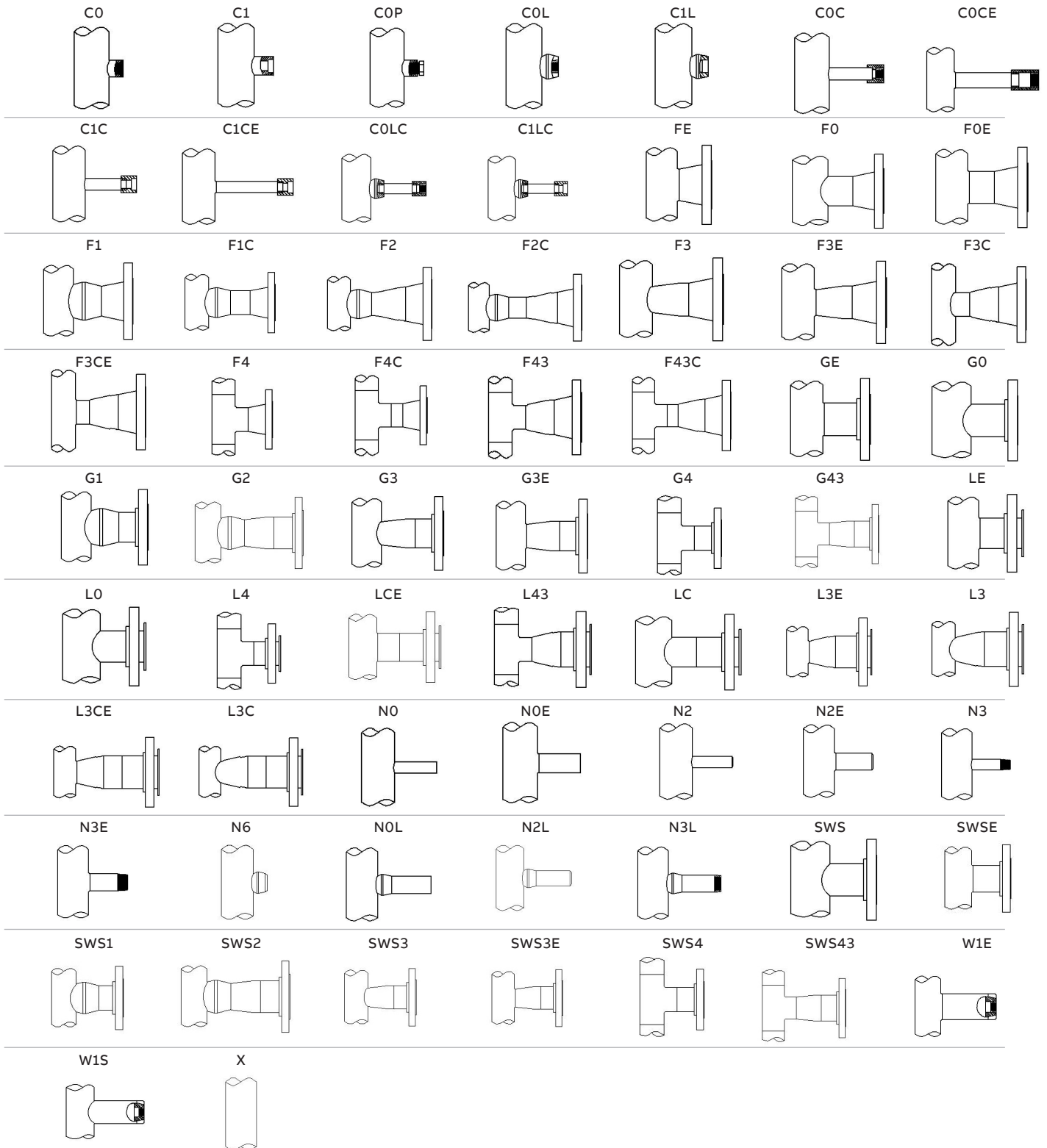

Figure2 Chamber configuration – side

Chamber configuration – bottom

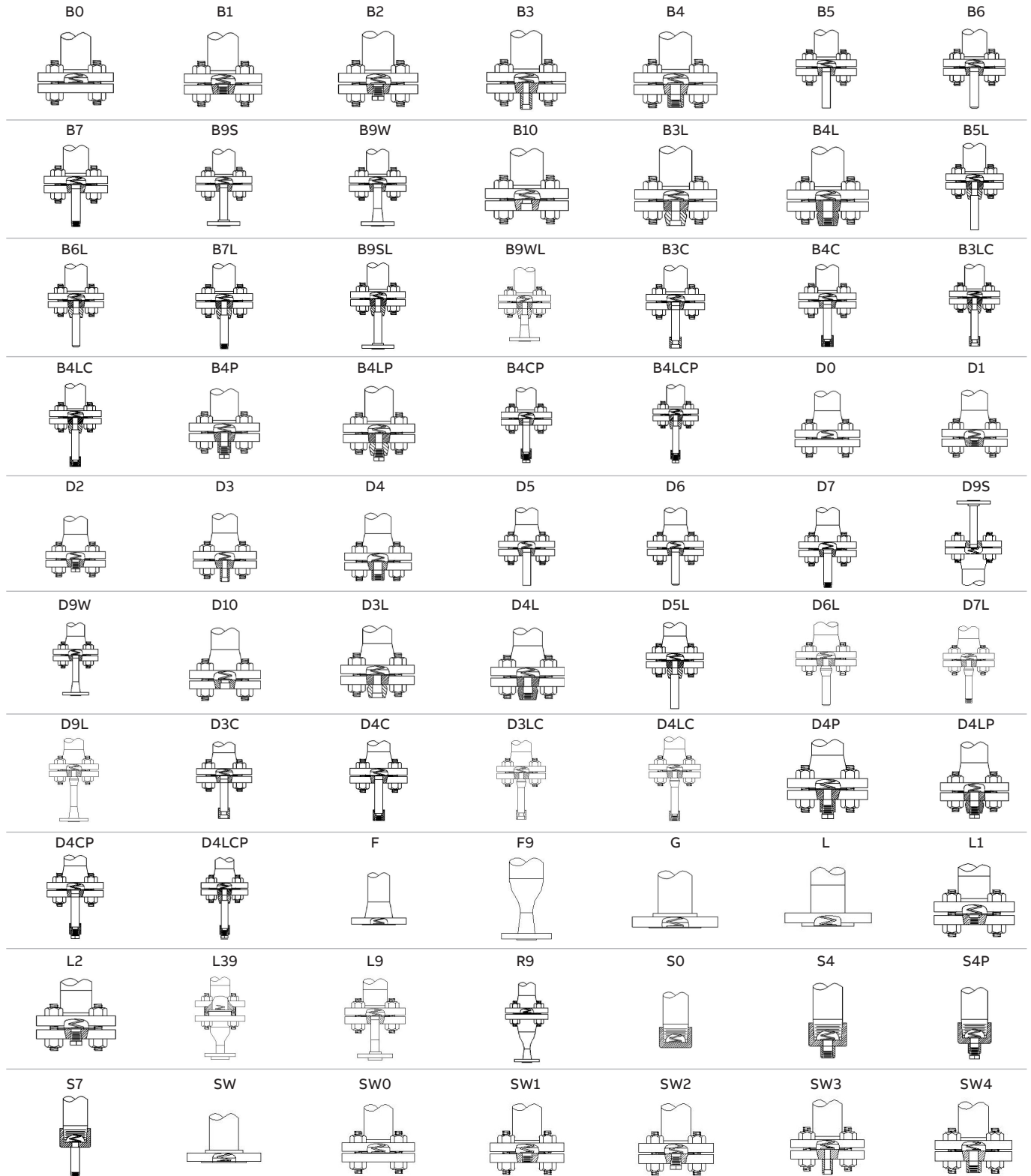

Figure3 Chamber configuration – bottom

...Chamber configuration – bottom

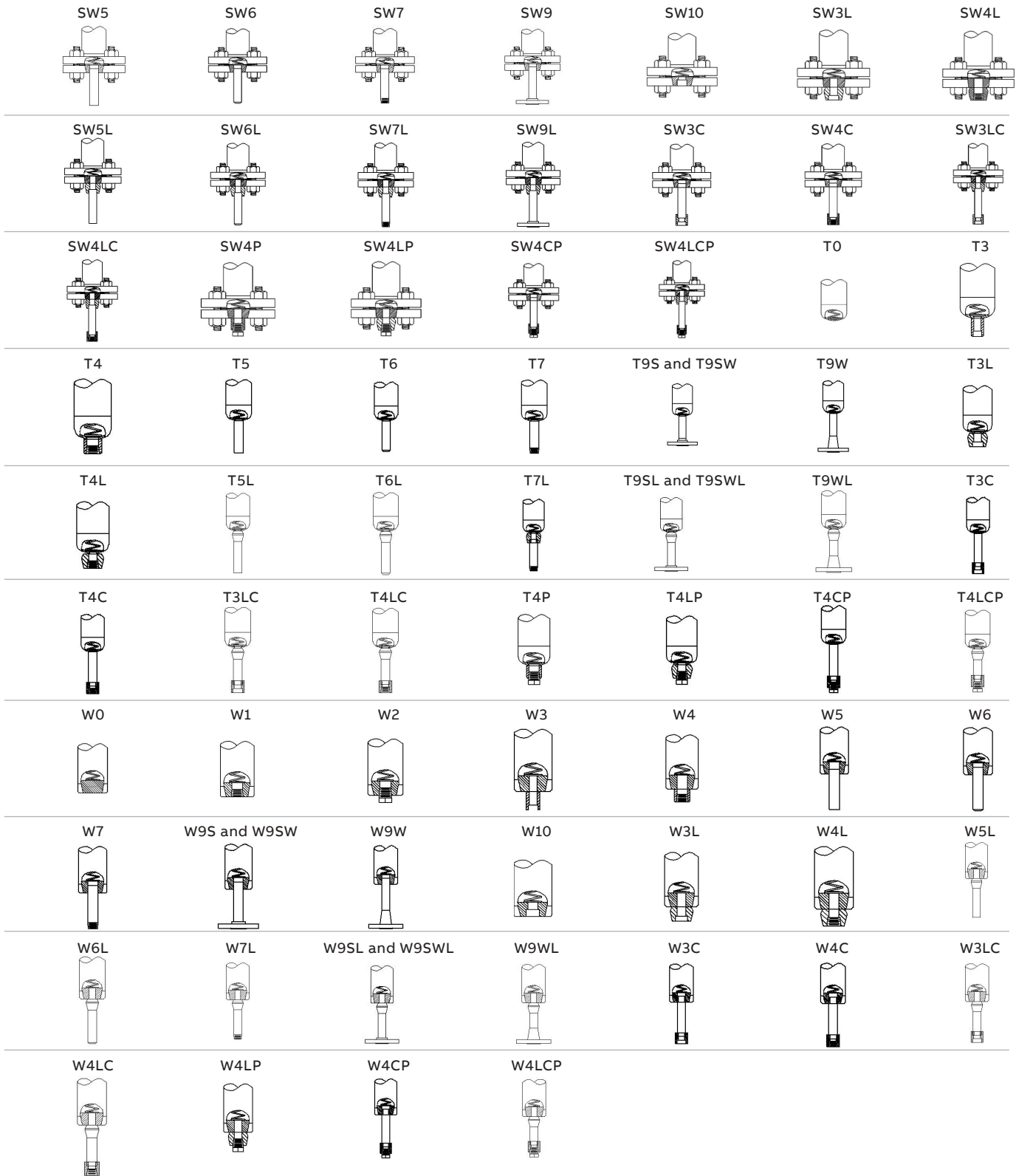

Figure3 Chamber configuration – bottom (continued)

Chamber configuration

Table 3
Size and rating designations for ASME B16.5 flanges

Size	Rating	Raised face	Flat face	Ring type joint	Male	Tongue
½ in.	150	R51	F51	N / A	M51	TG51
	300	R53	F53	J53	M53	TG53
	600	R56	F56	J56	M56	TG56
	900	R59	F59	J59	M59	TG59
	1500	R515	F515	J515	M515	TG515
	2500	R525	F525	J525	M525	TG525
¾ in.	150	R71	F71	N / A	M71	TG71
	300	R73	F73	J73	M73	TG73
	600	R76	F76	J76	M76	TG76
	900	R79	F79	J79	M79	TG79
	1500	R715	F715	J715	M715	TG715
	2500	R725	F725	J725	M725	TG725
1 in.	150	R11	F11	J11	M11	TG11
	300	R13	F13	J13	M13	TG13
	600	R16	F16	J16	M16	TG16
	900	R19	F19	J19	M19	TG19
	1500	R115	F115	J115	M115	TG115
	2500	R125	F125	J125	M125	TG125
1½ in.	150	R151	F151	J151	M151	TG151
	300	R153	F153	J153	M153	TG153
	600	R156	F156	J156	M156	TG156
	900	R159	F159	J159	M159	TG159
	1500	R1515	F1515	J1515	M1515	TG1515
	2500	R1525	F1525	J1525	M1525	TG1525
2 in.	150	R21	F21	J21	M21	TG21
	300	R23	F23	J23	M23	TG23
	600	R26	F26	J26	M26	TG26
	900	R29	F29	J29	M29	TG29
	1500	R215	F215	J215	M215	TG215
	2500	R225	F225	J225	M225	TG225
2½ in.	150	R251	F251	J251	M251	TG251
	300	R253	F253	J253	M253	TG253
	600	R256	F256	J256	M256	TG256
	900	R259	F259	J259	M259	TG259
	1500	R2515	F2515	J2515	M2515	TG2515
	2500	R2525	F2525	J2525	M2525	TG2525
3 in.	150	R31	F31	J31	M31	TG31
	300	R33	F33	J33	M33	TG33
	600	R36	F36	J36	M36	TG36
	900	R39	F39	J39	M39	TG39
	1500	R315	F315	J315	M315	TG315
	2500	R325	F325	J325	M325	TG325
4 in.	150	R41	F41	J41	M41	TG41
	300	R43	F43	J43	M43	TG43
	600	R46	F46	J46	M46	TG46
	900	R49	F49	J49	M49	TG49
	1500	R415	F415	J415	M415	TG415
	2500	R425	F425	J425	M425	TG425
6 in.	150	R61	F61	J61	M61	TG61
	300	R63	F63	J63	M63	TG63
	600	R66	F66	J66	M66	TG66
	900	R69	F69	J69	M69	TG69
	1500	R615	F615	J615	M615	TG615
	2500	R625	F625	J625	M625	TG625

...Chamber configuration

Table 3 (continued)
Size and rating designations for EN 1092 flanges¹

Size	Rating	Raised face (type B1)	Flat face (type A)
DN15	PN16	RAC	FAC
	PN25	RAD	FAD
	PN40	RAE	FAE
	PN63	RAF	FAF
	PN100	RAG	FAG
	PN160	RAH	FAH
	PN250	RAJ	FAJ
	PN320	RAK	FAK
DN20	PN16	RBC	FBC
	PN25	RBD	FBD
	PN40	RBE	FBE
	PN63	RBF	FBF
	PN100	RBG	FBG
	PN160	RBH	FBH
	PN250	RBJ	FBJ
	PN320	RBK	FBK
DN25	PN16	RCC	FCC
	PN25	RCD	FCD
	PN40	RCE	FCE
	PN63	RCF	FCF
	PN100	RCG	FCG
	PN160	RCH	FCH
	PN250	RCJ	FCJ
	PN320	RCK	FCK
DN40	PN16	REC	FEC
	PN25	RED	FED
	PN40	REE	FEE
	PN63	REF	FEF
	PN100	REG	FEG
	PN160	REH	FEH
	PN250	REJ	FEJ
	PN320	REK	FEK
DN50	PN16	RFC	FFC
	PN25	RFD	FFD
	PN40	RFE	FFE
	PN63	RFF	FFF
	PN100	RFG	FFG
	PN160	RFH	FFH
	PN250	RFJ	FFJ
	PN320	RFK	FFK

Note:

- 1 EN1092 Weld Neck flanges are type 11, EN1092 Slip On flanges are type 12.
- 2 Z9 shall be specified for any sizes / ratings not listed in table 3.

Size and rating designations for EN 1092 flanges

Size	Rating	Raised face (type B2)	Flat face (type A)
DN65	PN16	RGC	FGC
	PN25	RGD	FGD
	PN40	RGE	FGE
	PN63	RGF	FGF
	PN100	RGG	FGG
	PN160	RGH	FGH
	PN250	RGJ	FGJ
	PN320	RGK	FGK

Connection sizes and ratings

Table 3 (continued)
Size and rating designations for EN 1092 flanges (continued)

Size	Rating	Raised face (type B2)	Flat face (type A)
DN80	PN16	RHC	FHC
	PN25	RHD	FHD
	PN40	RHE	FHE
	PN63	RHF	FHF
	PN100	RHG	FHG
	PN160	RHH	FHH
	PN250	RHJ	FHJ
	PN320	RHK	FHK
DN100	PN16	RJC	FJC
	PN25	RJD	FJD
	PN40	RJE	FJE
	PN63	RJF	FJF
	PN100	RJG	FJG
	PN160	RJH	FJH
	PN250	RJJ	FJJ
	PN320	RJK	FJK
DN150	PN16	RMC	FMC
	PN25	RMD	FMD
	PN40	RME	FME
	PN63	RMF	FMF
	PN100	RMG	FMG
	PN160	RMH	FMH
	PN250	RMJ	FMJ
	PN320	RMK	FMK

Size and rating designations

Size	Rating	Sock-o-lets	Thread-o-lets	Plugs	Couplings
½ in.	3000#	S053	T053	P053	C053
	6000#	S056	T056	P056	C056
¾ in.	3000#	S073	T073	P073	C073
	6000#	S076	T076	P076	C076
1 in.	3000#	S103	T103	P103	C103
	6000#	S106	T106	P106	C106
1½ in.	3000#	S153	T153	P153	C153
	6000#	S156	T156	P156	C156
2 in.	3000#	S203	T203	P203	C203
	6000#	S206	T206	P206	C206

Size	Rating	Weld-o-lets	Pipe nipples
½ in.	SCH 40	W054	N054
	SCH 80	W058	N058
	SCH 160	W051	N051
¾ in.	SCH 40	W074	N074
	SCH 80	W078	N078
	SCH 160	W071	N071
1 in.	SCH 40	W104	N104
	SCH 80	W108	N108
	SCH 160	W101	N101
1½ in.	SCH 40	W154	N154
	SCH 80	W158	N158
	SCH 160	W151	N151
2 in.	SCH 40	W204	N204
	SCH 80	W208	N208
	SCH 160	W201	N201

...Connection sizes and ratings

Table 3 (continued)
Female threaded and socket weld connection designations

Size	FNPT Designation	FSW Designation
½ in.	FN05	SW05 ¹
¾ in.	FN07	SW07 ¹
1 in.	FN10	SW10 ¹
1½ in.	FN15	SW15 ¹
2 in.	FN20	SW20 ¹

Note:

1. Socket weld connections shall be schedule 40.

Transmitter and switch accessories

Magnetostrictive level transmitters

LMT200: refer to DS_LMT200-EN data sheet for ordering information

Magnetic level gauge switches

LMS100: refer to DS/LMS100-EN data sheet for ordering information

LMS200: refer to DS/LMS200-EN data sheet for ordering information

MS41: refer to DS/MS41-EN data sheet for ordering information

PS45: refer to DS/PS45-EN 2014 data sheet for ordering information

All data sheets are available on the ABB website at new.abb.com/products/measurement-products/level.

...Transmitter and switch accessories

Sample accessories

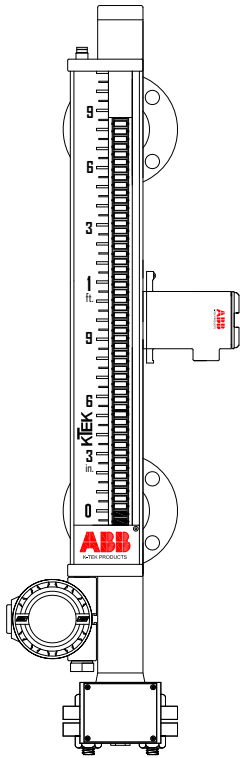

KM26 with LMT200 and MS41

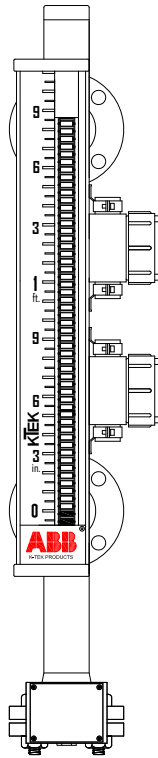

KM26 with 2 LMS200's

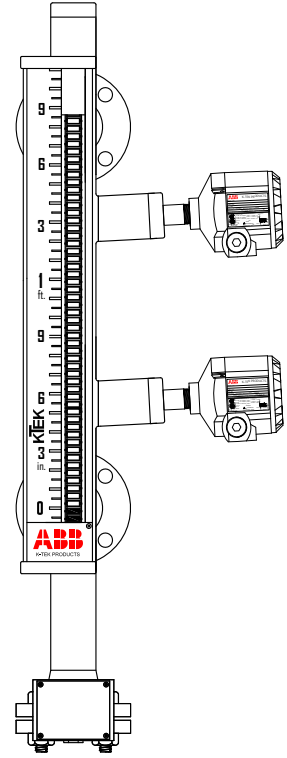

KM26 with side mounted insertion type switches

Figure4 Sample accessories

Example applications

Top process (from side) and bottom process (from bottom) of KM26 (center to face)

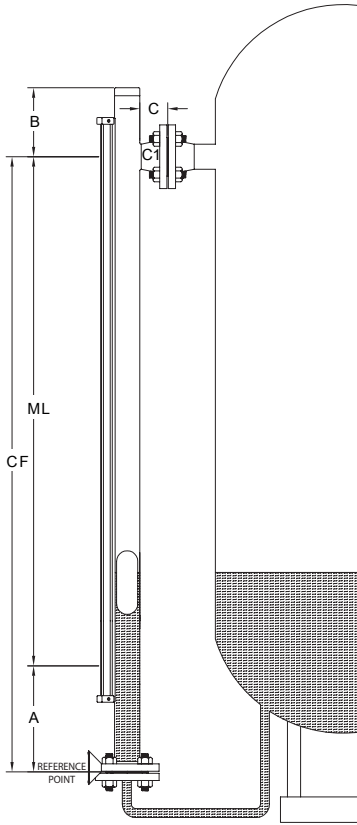

Sample model #:

KM26S.SS6.SS6.W0.FE.X.X.G.X.R21.X.X.R21.S3G.B.X-TT1

Note: The required CF and/or ML dimensions shall be specified by the customer.

Top process and bottom process (from top and bottom) of KM26 (face to face)

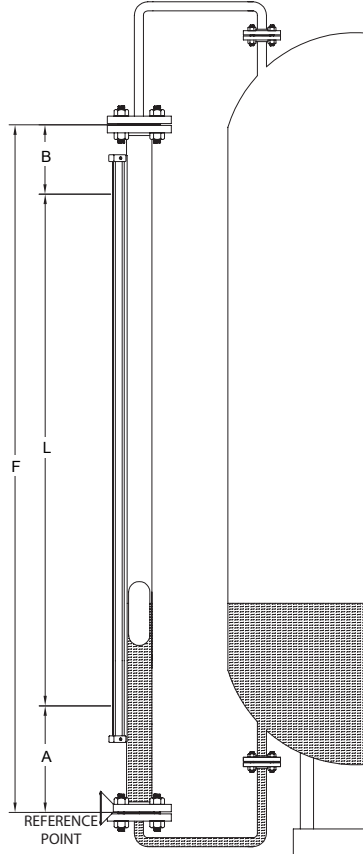

Sample model #:

KM26S.SS6.CST.G.X.X.G.R21.X.X.X.R21.S3P.C.X

Note: The required FF and/or ML dimensions (in addition to the desired A and B dimensions) shall be specified by the customer.

Top and bottom process connection (from side) of KM26 (center to center)

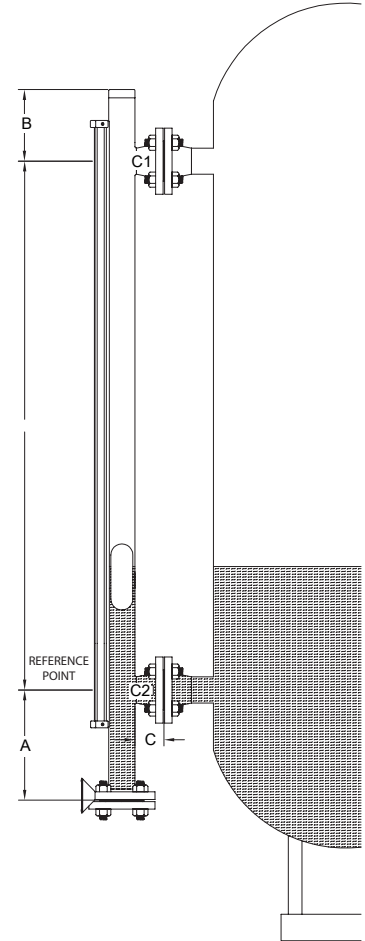

Sample model #:

KM26S.SS4.SS4.W0.FE.FE.X.B0.X.R23.R23.X.X.S3G.D.X

Figure 5 Example applications

...Example applications

Top process (from top) and bottom process (from bottom side) of KM26 (face to center)

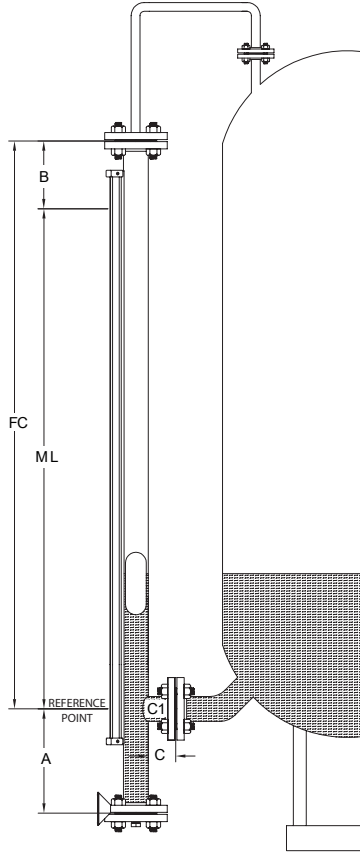

Sample model #:

KM26S.SS6.CST.G.G0.X.X.B2.R21.R21.X.X.P073.S3G.B.X

Note: The required FC and/or ML dimensions shall be specified by the customer.

Dual level application (center to center to center)

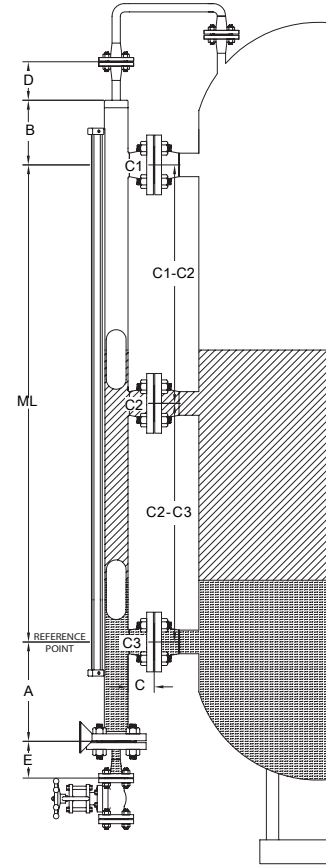

Sample model #:

KM26S.SS6.SS6.W9W.FE.FE.FE.B9W.R51.R21.R21.R51.M1GD.B.X-DV.Z99

Note: The distance between each side connection shall be specified by the customer.

Figure5 Example applications (continued)

Quotation request – KM26S – side mount

Factory contact: _____

Seller information

Name: _____
 Phone: _____
 Email: _____
 Company or LBU: _____
 Main phone: _____
 Fax: _____

End user information

Name: _____
 Phone: _____
 Email: _____
 Company or LBU: _____
 Main phone: _____
 Note: This information will be required before accepting an order.
 *All fields required

Tag ID#: _____

Process conditions

Application for (select one): total level – interface level – total and interface
 Upper fluid operating sp. gravity: _____
 Minimum specific gravity: _____
 Lower fluid second sp. gravity: _____
 Fluid(s): _____ If water, steam service? Yes No
 Operating temp: _____ Max. temp: _____ Min. temp: _____
 Operating pressure: _____ Max. pressure: _____
 Minimum ambient temperature: _____
 High vibration environment (such as compressor)? Yes No

Chamber and float details

Chamber material: _____
 Float material: _____
 Connection material: _____
 Center to center/ measuring length: _____
 Vent / drain type and size: _____

Process connection

Type: _____
 Size: _____
 Rating: _____

Indicator details

Select: ___ Shuttle or
 ___ Bar graph (choose color combination) yellow/black – red/white
 Scale (select one): ft. / in. – running in. (½ in. div.) – running in. (1/8 in.) – meter / cm – custom _____
 Special requirements: _____

Accessories Required (choose all that apply)

___ Chamber insulation
 ___ Electric heat tracing
 ___ Steam jacket
 ___ Steam tracing
 ___ Magnetic particle traps
 ___ Specialty process connection (specify type: _____)
 ___ Switches (specify type: _____)
 ___ Transmitter – LMT200 (select: HART or FF)

Approval or Documentation required:

___ CRN
 ___ ASME
 ___ PED
 ___ ATEX CONSTRUCTIONAL SAFETY
 ___ NACE
 ___ Other

...Quotation request – KM26S – side mount

Choose the appropriate configuration below or attach a sketch

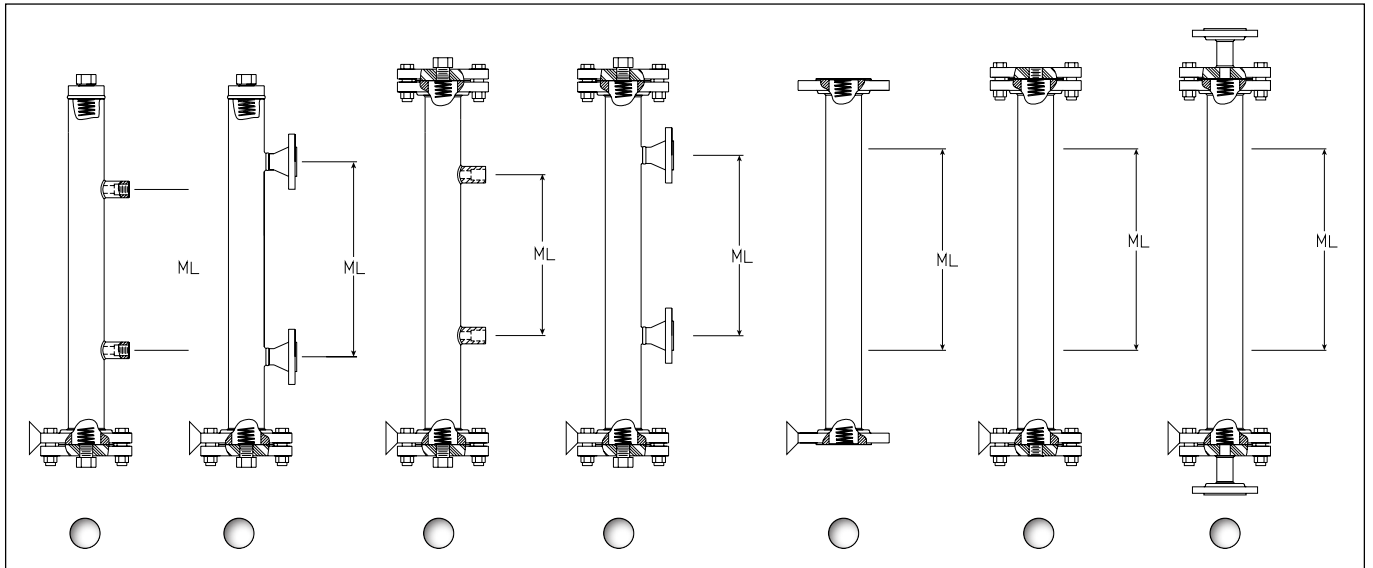

Select orientation (only 1 accessory allowed per position)

Indicator: __90° __180° __270°

Transmitter: __90° __180° __270°

Switches: __90° __180° __270°

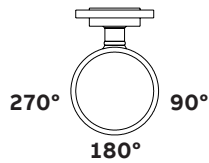

Note: Overall length will always be greater than measuring length (ML). Please specify if a max overall length is required.

—
Notes

Notes

ABB Inc.**Measurement and Analytics**

7051 Industrial Blvd

Bartlesville, OK 74006

USA

Tel: +1 918 338 4888

Email: quotes: us-iama-quotes@abb.com

ABB Engineering (Shanghai) Ltd.**Measurement and Analytics**

No. 4528, Kangxin Highway

Pudong District, Shanghai

201319

P.R. China

Phone: 400 820 9696

Fax: +86 21 6105 6677

Email: instrumentservice.abbchina@cn.abb.com











new.abb.com/products/measurement-products/level

We reserve the right to make technical changes or modify the contents of this document without prior notice. With regard to purchase orders, the agreed particulars shall prevail. ABB does not accept any responsibility whatsoever for potential errors or possible lack of information in this document.

We reserve all rights in this document and in the subject matter and illustrations contained therein. Any reproduction, disclosure to third parties or utilization of its contents – in whole or in parts – is forbidden without prior written consent of ABB.



Our offering:

	Actuators and Positioners		Analytical Instruments
	Device Management, Fieldbus and Wireless		Flow Measurement
	Force Measurement		Level Measurement
	Natural Gas Measurement		Pressure Measurement
	Recorders and Controllers		Temperature Measurement

HMI – Automação e Instrumentação, Lda.

Travessa da Indústria, nº 111
4780-573 Santo Tirso
PORTUGAL

Tel. +351 252 850 501
Fax. +351 300 013 487

Web: www.hmi.pt

Email: hmi@hmi.pt