



hmi

high-accuracy
measurement
instruments

FICHA TÉCNICA DE PRODUTO

PRODUCT DATASHEET

HMI – Automação e Instrumentação, Lda.

Travessa da Indústria, nº 111
4780-573 Santo Tirso
PORTUGAL

Tel. +351 252 850 501
Fax. +351 300 013 487

Web: www.hmi.pt

Email: hmi@hmi.pt

ABB MEASUREMENT & ANALYTICS | DATA SHEET

FSM4000

Electromagnetic flowmeter



Measurement made easy

The ultimate solution for the most demanding applications

Outstanding performance

- The FSM4000 takes on the task where all other flowmeters fail.

FSM4000 for optimal operational security in all demanding applications

- Sludges with high level of solids
- High level of pulp
- Concentrated sludge

Durability for a maximum service life

- Long-lasting liner materials are resistant to abrasion and corrosion
- No additional wear caused by protruding parts in the meter tube

General properties

- Nominal diameter DN 3 to 1000 ($\frac{1}{16}$ to 40 ")
- Pressure rating PN 10 to PN 40; ASME CL150, CL300
- Process connection: flange in accordance with DIN/EN, ASME
- Liner materials: PFA, PTFE, hard rubber, soft rubber and ceramic carbide
- Digital communication via HART®, PROFIBUS PA® or FOUNDATION Fieldbus® protocol

Overview – models

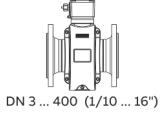
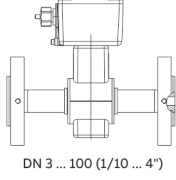
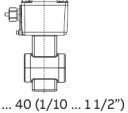
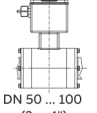
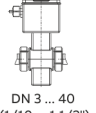
Housing material	Alu. Housing, Series 4000				Stainless Steel Housing, Series 2000						
	 DN 3 ... 400 (1/10 ... 16")		 DN 3 ... 100 (1/10 ... 4")		 DN 3 ... 40 (1/10 ... 1 1/2")		 DN 50 ... 100 (2 ... 4")		 DN 3 ... 40 (1/10 ... 1 1/2")		
	Fixed Flange		Fixed Flange		Wafer type		Variable Connections				
1) Welded spud					3) Pipe fitting						
2) Tri-clamp					4) Male thread						
Sensor											
Model number	SE41F		SE21F		SE21W		SE21_*				
Measured error	0.5% of rate (> DN 2)										
	DN	PN	DN	PN	DN	PN	DN	PN	*		
Wafer type	—	—	—	—	3 to 50 65 to 100	10 to 40 10 to 16	—	—	—	—	
Flange DIN 2501/EN 1092-1	3 to 1000	10 to 40	3 to 100	—	10 to 40	—	—	—	—	—	
Flange ASME B16.5/B16.47	1/10 to 40"	CL 150	1/10 to 4"	CL150 to	1/10" bis 2"	CL300/JIS	—	—	—	—	
JIS B2210-10K	1/10 to 12"	CL 300	—	CL300/JIS	3" bis 4"	CL150/JIS	—	—	—	—	
Pipe fitting DIN 11851	—	—	—	—	—	—	3 to 40 (1/10 to 1 1/2") 50, 80 (2", 3") 65, 100 (2 1/2", 4")	40 16 10	S S S	—	
Weld stubs DIN 11850	—	—	—	—	—	—	3 to 40 (1/10 to 1 1/2") 50, 80 (2", 3") 65, 100 (2 1/2", 4")	40 16 10	R R R	—	
Welded spuds DIN 2463 / ISO 1127	—	—	—	—	—	—	3 to 40 (1/10 to 1 1/2") 50, 80 (2", 3") 65, 100 (2 1/2", 4")	40 16 10	Q/J Q/J Q/J	—	
Weld stubs ISO 2037 / SMS	—	—	—	—	—	—	25 to 40 (1 to 1 1/2") 50, 80 (2", 3") 65, 100 (2 1/2", 4")	40 16 10	P/X P/X P/X	—	
Tri-clamp DIN 32676 / ASME BPE	—	—	—	—	—	—	3 to 50 (1/10 to 2") 65, 100 (2 1/2", 4")	16/10 10/10	T/K T/K	—	
External thread ISO 228 / DIN 2999	—	—	—	—	—	—	3 to 25 (1/10 bis 1")	16	E	—	
Liner	Hard/soft rubber, ceramic carbide, PTFE, PFA, ETFE, other				PFA (vacuum-tight)		PFA, PFA vacuum-tight				
Conductivity	≥ 20 μS/cm (optional ≥ 0.5 μS/cm)										
Electrodes	Stainless steel 1.4571 (316 Ti), 1.4539 (904 L), Hastelloy B-3/C-4, platinum-iridium, tantalum, titanium										
Process connection material	Steel, stainless steel				—		Stainless steel 1.4404 (316 L)				
IP degree of protection in accordance with EN 60529	IP 65 / IP 67 / IP 68				IP 65 / IP 67 / IP 68		IP 65 / IP 67 / IP 68				
Measuring medium temperature	-25 to 130 °C / 180 °C (-13 to 266 °F / 356 °F)		-25 to 130 °C (-13 to 266 °F)		-40 to 130 °C (-40 to 266 °F)		-25 to 130 °C (-13 to 266 °F)				

... Overview – models

Approvals

Model number	SE41F	SE21F	SE21W	SE21_*
Hygienic and sterile requirements	—	CIP/SIP capable		3A, CIP/SIP capable
Pressure Equipment Directive 97/23/EC	Conformity assessment in accordance with category III, fluid group 1			
CRN (Canadian Reg. Number)	On request			

Transmitter

Model number	S4
Power supply	85 to 253 V AC, 24 V AC/DC
Current output	0/2 to 10 mA, 0/4 to 20 mA
Pulse output	active (24 V), optocoupler (220 mA)
Ext. output switch-off	yes
Ext. totalizer reset	yes
Forward / reverse flow measurement	yes
Communication	HART® protocol, PROFIBUS PA®, FOUNDATION Fieldbus®
Pipe empty detection std.	yes, DN 10 or higher and $\geq 20 \mu\text{S/cm}$
Self-monitoring, extended diagnosis functions	yes, extended diagnostic functions / fingerprint only in connection with sensors SE21, SE21F and SE41F for DN 10 or higher
Local display / totalization	yes
Density correction	yes, manual entry (totalize and display in mass units)
IP rating in accordance with EN 60529	IP 65 / IP 67, NEMA 4X
Chassis	Field mount housing

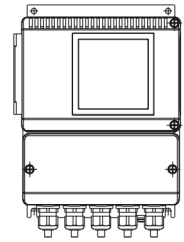

General data

Measuring accuracy

Reference conditions in accordance with EN 29104

Measuring medium temperature	20 °C (68 °F) ±2 K
Ambient temperature	20 °C (68 °F) ±2 K
Power supply	Nominal voltage as per name plate UN ± 1 %
Installation conditions	<ul style="list-style-type: none"> Inlet section: > 10 × DN straight section Outlet section: > 5 × DN straight section DN = Sensor nominal diameter
Warm-up phase	30 min

Maximum measuring error

Pulse output

- DN 3 to DN 1000 ($\frac{1}{10}$ to 40"):
 - $Q > 0.05 Q_{max}DN \pm 0.5 \%$ of measured value
 - $Q < 0.05 Q_{max}DN \pm 0.00025 Q_{max}DN$
- $Q_{max}DN$ = maximum flow rate of the nominal diameter at 10 m/s

Analog output effects

Same as pulse output plus $\pm 0.1 \%$ of measured value ± 0.01 mA

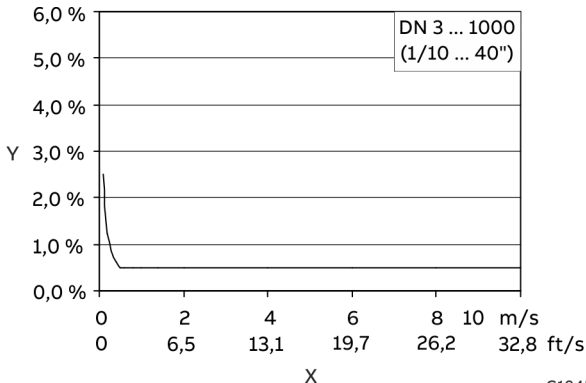

Y Measured error ± of measured value
X Flow velocity v

Figure 1: Analog output effects

Grounding

The grounding of the flowmeter sensor is essential for both safety reasons, and to ensure trouble-free operation of the electromagnetic flowmeter.

The ground screws on the flowmeter sensor are to be brought to ground potential. For technical reasons, this potential should be identical to the potential of the metering fluid, if possible.

For plastic or insulated lined pipelines, the fluid is grounded by installing ground plates. When there are stray potentials present in the pipeline, we recommend installing a ground plate on both ends of the flowmeter sensor.

To comply with the EMC and Low Voltage Directives, the connection box/ transmitter must be grounded in addition to the meter tube of the flowmeter sensor.

Installation conditions

Flow direction

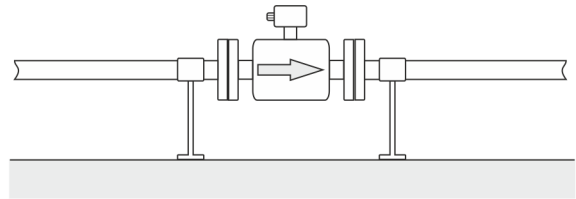
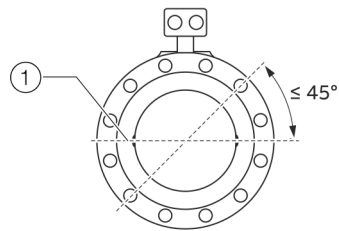

Figure 2: Flow direction

The device measures the flow rate in both flow directions. Forward flow is the factory setting, as shown in Figure 2.

Electrode axis



① Electrode axis

Figure 3: Orientation of the electrode axis

The flowmeter sensor should be mounted in the piping in such a manner that the electrode axis is oriented as horizontally as possible.

A maximum deviation of 45° from the horizontal position is permissible.

... General data

Inlet and outlet sections

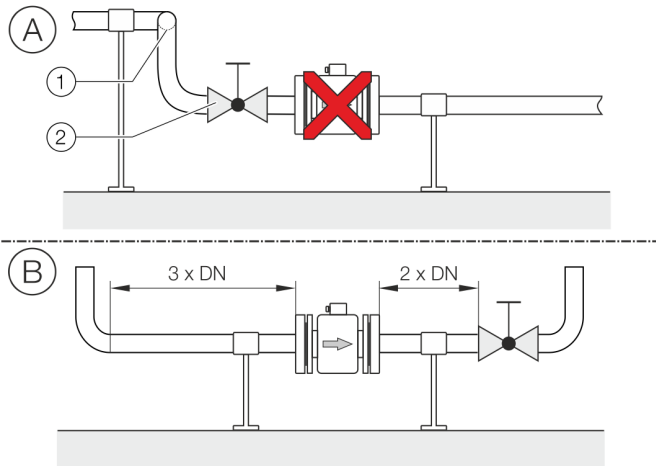

- ① Double manifold ② Turn-off device

Figure 4: Inlet and outlet section, turn-off devices

The measuring principle is independent of the flow profile as long as standing eddies do not extend into the measured value formation, such as may for example occur after double manifolds, in the event of tangential inflow, or where half-open gate valves are located upstream of the sensor. In such cases, measures must be put in place to normalize the flow profile.

- Ⓐ Do not install fittings, manifolds, valves, etc., right before the flowmeter sensor.
- Ⓑ Inlet / outlet sections: length of the straight piping upstream and downstream on the sensor.
Experience has shown that, in most installations, straight inlet sections $3 \times \text{DN}$ long and straight outlet sections $2 \times \text{DN}$ long are sufficient (DN = nominal diameter of the flowmeter sensor).
For test stands, the reference conditions of $10 \times \text{DN}$ straight inlet and $5 \times \text{DN}$ straight outlet must be provided, in accordance with EN 29104 / ISO 9104.
Valves or other turn-off devices should be installed in the outlet section.
Valve flaps must be installed so that the valve damper plate does not extend into the flowmeter sensor.

Mounting position

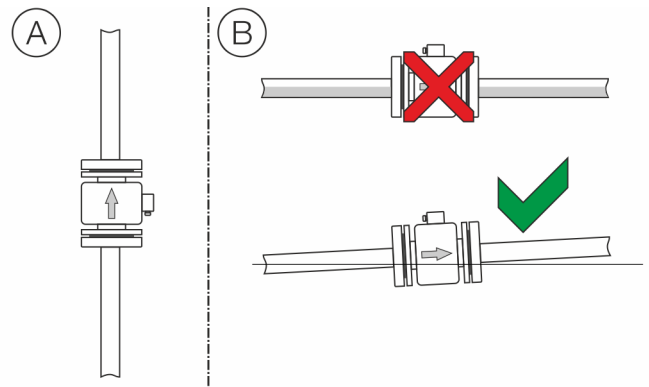

Figure 5: Mounting position

- Ⓐ Vertical installation for measuring abrasive materials, preferably with flow in upward direction.
- Ⓑ For a horizontal installation, the meter tube must always be completely filled with the measuring medium. Provide for a slight incline of the connection for degassing.

Free inlet or outlet

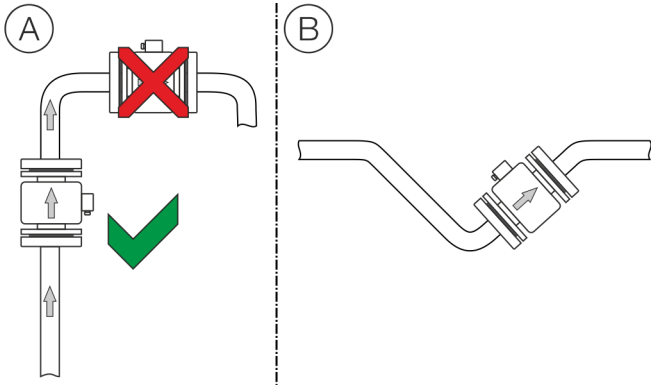

Figure 6: Free inflow and outflow

- Ⓐ For a free outflow, do not install flowmeter at the highest point of the piping or on its outflow side, since the measuring tube may run empty, creating air bubbles.
- Ⓑ For free inflow/outflow, provide an invert to make sure that the piping is always full

Mounting with heavily contaminated measuring media

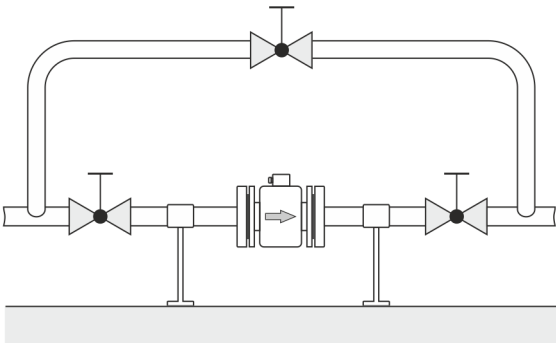
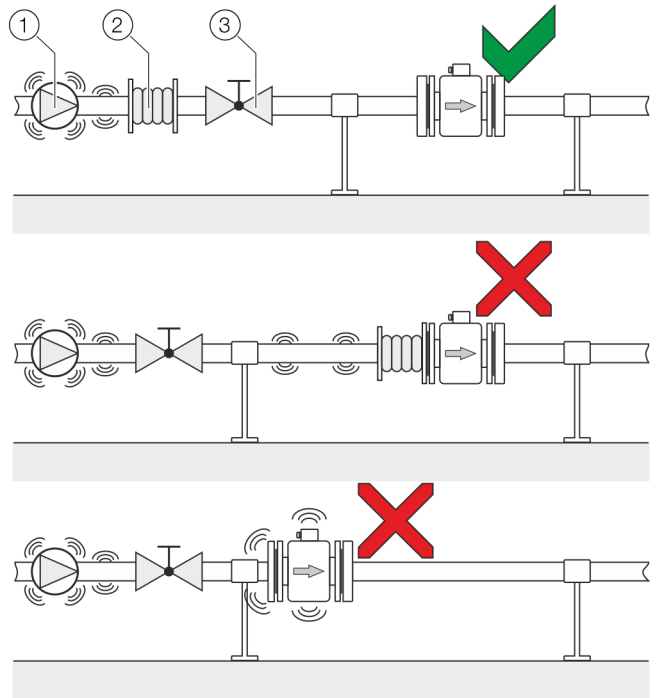

Figure 7: Bypass line

For strongly contaminated measuring media, a bypass line in accordance with the figure is recommended so that operation of the system can continue to run without interruption during mechanical cleaning.

Mounting with pipe vibration



- ① Pump
- ② Damping device
- ③ Turn-off device

Figure 8: Vibration damping

If pipe vibration occurs, it needs to be damped using damping devices. The damping devices must be installed outside the support section and outside of the piping section between the turn-off devices. Avoid connecting damping devices directly to the flowmeter sensor.

Sensor insulation

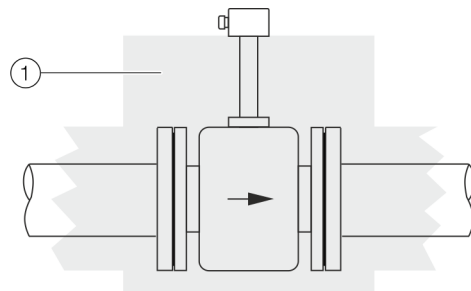

- ① Insulation

Figure 9: Insulation of the flowmeter sensor

In the high temperature design, the flowmeter sensor can be completely thermally insulated. After the unit is installed, the piping and sensor must be insulated in accordance with the figure.

... General data

Installation in piping with larger nominal diameter

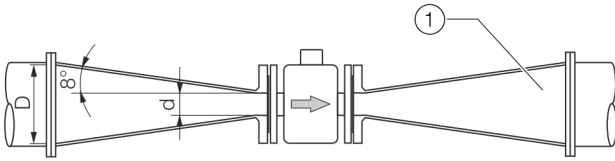

① Reducer

Figure 10: Using reducers

Determine the resulting pressure loss when using reducers:

1. Determine diameter ratios d/D .
2. Determine the flow velocity based on the flow rate nomogram (Figure 11).
3. Read the pressure loss on the Y-axis in Figure 11.

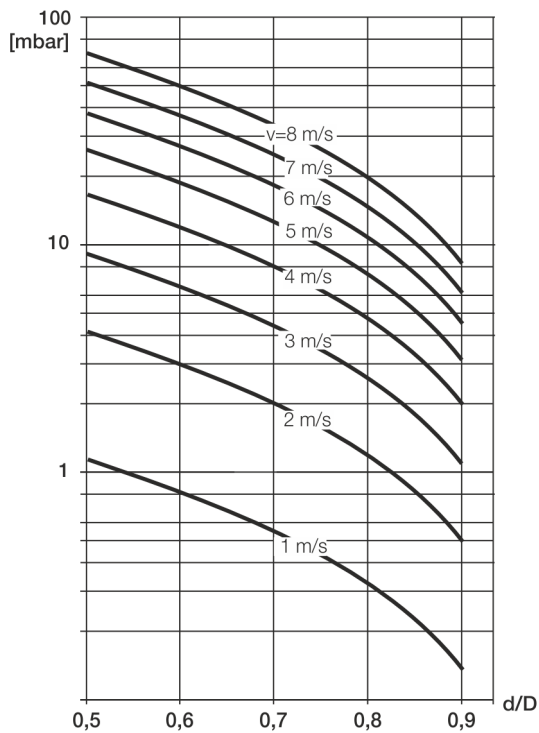

Figure 11: Flow rate nomogram for flange transition piece at $\alpha/2 = 8^\circ$

Nominal diameter, nominal pressure, measuring range

Nominal diameter DN	Standard pressure rating PN	Min. flow velocity measuring range 0 to 0.5 m/s					Max. flow velocity measuring range 0 to 10 m/s					
3	1/10	40	0	up to 0.2	l/min	0.0529	US gal/min	0	up to 4	l/min	1.06	US gal/min
4	5/32	40	0	up to 0.4	l/min	0.1	US gal/min	0	up to 8	l/min	2.1	US gal/min
6	1/4	40	0	up to 1	l/min	0.3	US gal/min	0	up to 20	l/min	5.3	US gal/min
8	5/16	40	0	up to 1.5	l/min	0.4	US gal/min	0	up to 30	l/min	7.9	US gal/min
10	3/8	40	0	up to 2.25	l/min	0.6	US gal/min	0	up to 45	l/min	12	US gal/min
15	1/2	40	0	up to 5.0	l/min	1.3	US gal/min	0	up to 100	l/min	36	US gal/min
20	3/4	40	0	up to 7.5	l/min	2.0	US gal/min	0	up to 150	l/min	40	US gal/min
25	1	40	0	up to 10	l/min	2.6	US gal/min	0	up to 200	l/min	53	US gal/min
32	1 1/4	40	0	up to 20	l/min	5.3	US gal/min	0	up to 400	l/min	106	US gal/min
40	1 1/2	40	0	up to 30	l/min	7.9	US gal/min	0	up to 600	l/min	159	US gal/min
50	2	40	0	up to 3	m3/h	13	US gal/min	0	up to 60	m3/h	264	US gal/min
65	2 1/2	40	0	up to 6	m3/h	26	US gal/min	0	up to 120	m3/h	528	US gal/min
80	3	40	0	up to 9	m3/h	40	US gal/min	0	up to 180	m3/h	793	US gal/min
100	4	16	0	up to 12	m3/h	53	US gal/min	0	up to 240	m3/h	1057	US gal/min
125	5	16	0	up to 21	m3/h	92	US gal/min	0	up to 420	m3/h	1849	US gal/min
150	6	16	0	up to 30	m3/h	132	US gal/min	0	up to 600	m3/h	2642	US gal/min
200	8	10/16	0	up to 54	m3/h	238	US gal/min	0	up to 1080	m3/h	4755	US gal/min
250	10	10/16	0	up to 90	m3/h	396	US gal/min	0	up to 1800	m3/h	7925	US gal/min
300	12	10/16	0	up to 120	m3/h	528	US gal/min	0	up to 2400	m3/h	10567	US gal/min
350	14	10/16	0	up to 165	m3/h	726	US gal/min	0	up to 3300	m3/h	14529	US gal/min
400	16	10/16	0	up to 225	m3/h	991	US gal/min	0	up to 4500	m3/h	19813	US gal/min
450	18	10/16	0	up to 300	m3/h	1321	US gal/min	0	up to 6000	m3/h	26417	US gal/min
500	20	10	0	up to 330	m3/h	1453	US gal/min	0	up to 6600	m3/h	29059	US gal/min
600	24	10	0	up to 480	m3/h	2113	US gal/min	0	up to 9600	m3/h	30380	US gal/min
700	28	10	0	up to 660	m3/h	2906	US gal/min	0	up to 13200	m3/h	58118	US gal/min
800	32	10	0	up to 900	m3/h	3963	US gal/min	0	up to 18000	m3/h	79252	US gal/min
900	36	10	0	up to 1200	m3/h	5283	US gal/min	0	up to 24000	m3/h	105669	US gal/min
1000	40	10	0	up to 1350	m3/h	5944	US gal/min	0	up to 27000	m3/h	118877	US gal/min

... General data

Flange design and pressure rating

Nominal diameter	Flange ¹⁾	Material	PN
3 to 25 ($\frac{1}{16}$ to 1")	DIN	Stainless steel or steel	40, 63, 100 bar ²⁾
	ASME		CL150, CL300, CL600 ³⁾
	JIS		10 bar
32 (1 $\frac{1}{4}$ ")	DIN	Stainless steel or steel	40 bar
	ASME		CL150, CL300
	JIS		10 bar
40 (1 $\frac{1}{2}$ ")	DIN	Stainless steel or steel	40, 63, 100 bar
	ASME		CL150, CL300, CL600
	JIS		10 bar
50 (2")	DIN	Stainless steel or steel	40, 63, 100 bar
	ASME		CL150, CL300, CL600
	JIS		10 bar
65 (2 $\frac{1}{2}$ ")	DIN	Stainless steel or steel	16, 40, 63, 100 bar
	ASME		CL150, CL300, CL600
	JIS		10 bar
80 (3")	DIN	Stainless steel or steel	40, 63, 100 bar
	ASME		CL150, CL300, CL600
	JIS		10 bar
100 (4")	DIN	Stainless steel or steel	16, 40, 63, 100 bar
	ASME		CL150, CL300, CL600
	JIS		10 bar
125 (5")	DIN	Stainless steel or steel	16, 40, 63, 100 bar
	ASME		CL150, CL300
	JIS		10 bar
150 (6")	DIN	Stainless steel or steel	16, 40, 63, 100 bar
	ASME		CL150, CL300, CL600
	JIS		10 bar
	ASME		CL150

Nominal diameter	Flange ¹⁾	Material	PN
200 (8")	DIN	Stainless steel or steel	10, 16, 25, 40, 63, 100 bar
	ASME		CL150, CL300, CL600
	JIS		10 bar
250 (10")	DIN	Stainless steel or steel	10, 16, 25, 40 bar
	ASME		CL150, CL300
	JIS		10 bar
300 (12")	DIN	Stainless steel or steel	10, 16, 25, 40 bar
	ASME		CL150, CL300
	JIS		10 bar
350 to 600 (14 to 24")	DIN	Stainless steel or steel	10, 16, 25 bar
	ASME		CL150, CL300
	JIS		10 bar
700 to 1000 (28 to 40")	DIN	Stainless steel or steel	10, 16, 25 bar
	ASME		CL150

1) Connection dimensions for the flange in accordance with DIN2501 / EN1092-1 or ASME or JIS.

2) PN63, PN100 available from nominal diameter DN 25.

3) CL600 available from nominal diameter DN 25.

Other meter sizes, pressure stages and temperature classes are available upon request.

Flow rate nomogram

The volume flowrate is a function of the flow velocity and the diameter of the flowmeter. The flowrate nomograph indicates the flowrate range for a specific flowmeter nominal diameter and which flowmeter nominal diameters are suitable for a specific flowrate.

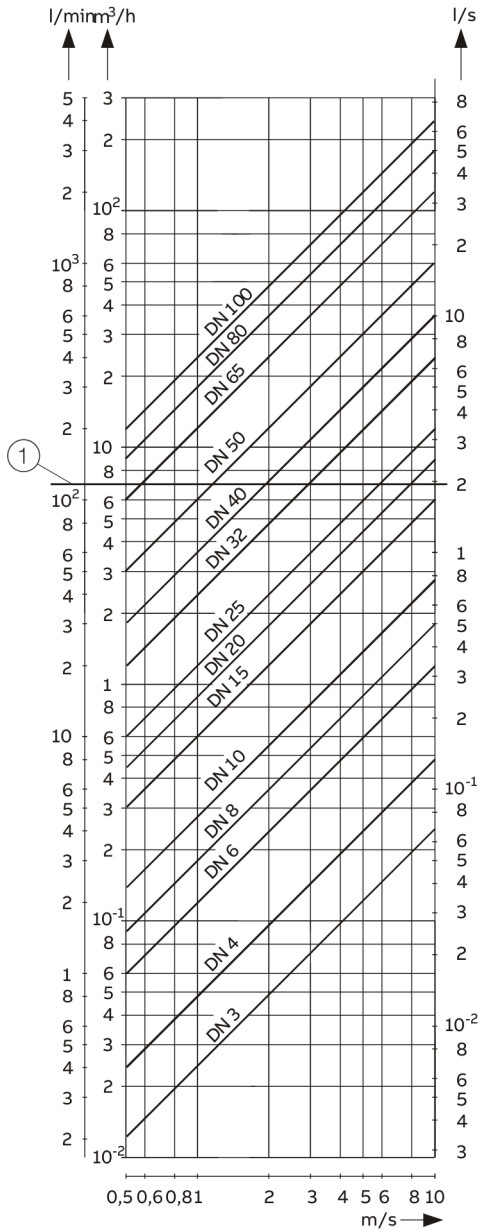

① Example

Figure 12: Flow rate nomogram DN 3 to DN 100 (10 to 4")

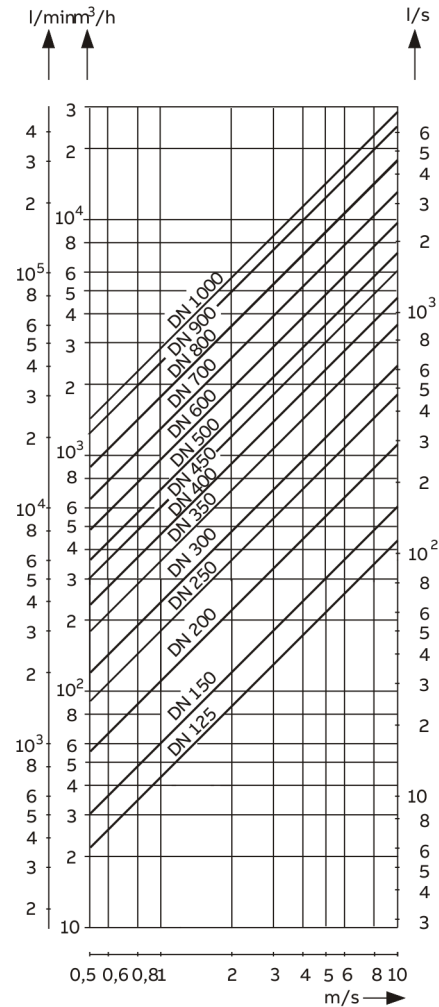

Figure 13: Flow rate nomogram, DN 125 to DN 1000 (5 to 40")

Example:

Flowrate = 7 m³/h (max. value = range end value). Sensors with nominal diameters DN 20 to DN 65 (¾ to 2½") are suited for a flow velocity of 0.5 to 10 m/s.

Model SE41F

Specifications

Temperature graph

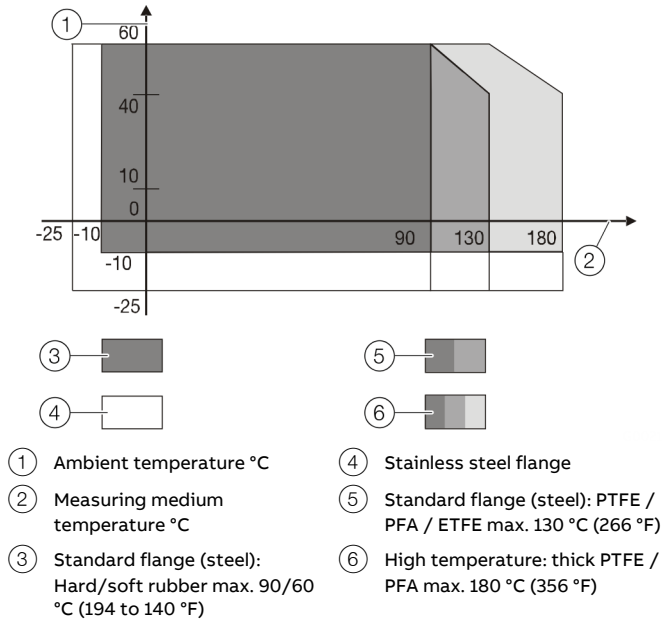

Figure 14: Measuring medium temperature dependent on the ambient temperature

Max. permissible cleaning temperature PTFE-, PFA-design

CIP cleaning	Liner Flowmeter sensor	T _{max}	t _{max} Min	T _{amb.}
Steam cleaning	PTFE, PFA	150 °C (302 °F)	60	25 °C (77 °F)
Wet cleaning	PTFE, PFA	140 °C (284 °F)	60	25 °C (77 °F)

If the ambient temperature is > 25 °C, the difference must be subtracted from the max. cleaning temperature.

$$T_{\max} - \Delta \text{ °C} \cdot \Delta \text{ °C} = (T_{\text{amb.}} - 25 \text{ °C})$$

Weight

Refer to **Dimensions** on page 31.

Min. permissible pressure as a function of measuring medium temperature

Liner	Nominal diameter DN	P _{Operation} at mbar abs	T _{Operation}
Hard rubber	15 to 1000 (1/2 to 40")	0	< 90 °C (194 °F)
Soft rubber	50 to 1000 (2 to 40")	0	< 60 °C (140 °F)
PTFE	10 to 600 (3/8 to 24")	270	< 20 °C (68 °F)
		400	< 100 °C (212 °F)
		500	< 130 °C (266 °F)
Thick PTFE high temperature design	25 to 80 (1 to 3") 100 to 250 (4 to 10") 300 (12")	0	< 180 °C (356 °F)
		67	< 180 °C (356 °F)
PFA	3 to 200 (1/10 to 8")	0	< 130 °C (266 °F)
		0	< 180 °C (356 °F)
ETFE	25 to 1000 (1 to 40")	100	< 130 °C (266 °F)
Ceramic carbide	25 to 1000 (1 to 40")	0	< 80 °C (176 °F)

Sensor material

Parts	Standard	Others
Liner	PTFE, PFA, hard rubber, soft rubber, ETFE	Ceramic carbide
Signal and ground electrode for	Stainless steel 1.4571 (316 Ti)	Hastelloy B-3 (2.4600), Hastelloy C-4 (2.4610), titanium, tantalum, platinum-iridium, stainless steel 1.4539 (904 L)
• Hard rubber		
• Soft rubber		
• PTFE, PFA, ETFE	Hastelloy C-4 (2.4610)	Stainless steel 1.4571 (316 Ti), Hastelloy B-3 (2.4600), titanium, tantalum, platinum-iridium, stainless steel 1.4539 (904 L)
Grounding plate	Stainless steel 1.4571 (316 Ti)	On request
Protection plate	Stainless steel 1.4571 (316 Ti)	On request

Storage temperature

-20 to 70 °C (-4 to 158 °F)

IP rating in accordance with EN 60529

IP 65/IP 67

IP 68 (option)

Pipe vibration according to EN 60068-2-6**Transmitter**

- In the range of 10 to 55 Hz, max. deflection 0.15 mm

Sensor

- In the range of 10 to 55 Hz, max. deflection 0.15 mm
- In the range of 10 to 55 Hz, max. acceleration 2 g

Designs

The flange devices are compliant with the installation lengths determined according to ISO 13359.

Material loads for process connections

Limits for allowable fluid temperature (TS) and allowable pressure (PS) are a function of the liner and flange material used (see the factory tag and name plate of the unit).

... Model SE41F

Dimensions

Flange DN 3 to 100 (1/16 to 4”), aluminum sensor housing (shell housing)

All specified dimensions and weights are in mm (in) or kg (lb). The specified weights are approximate figures. The maximum weight is always provided.

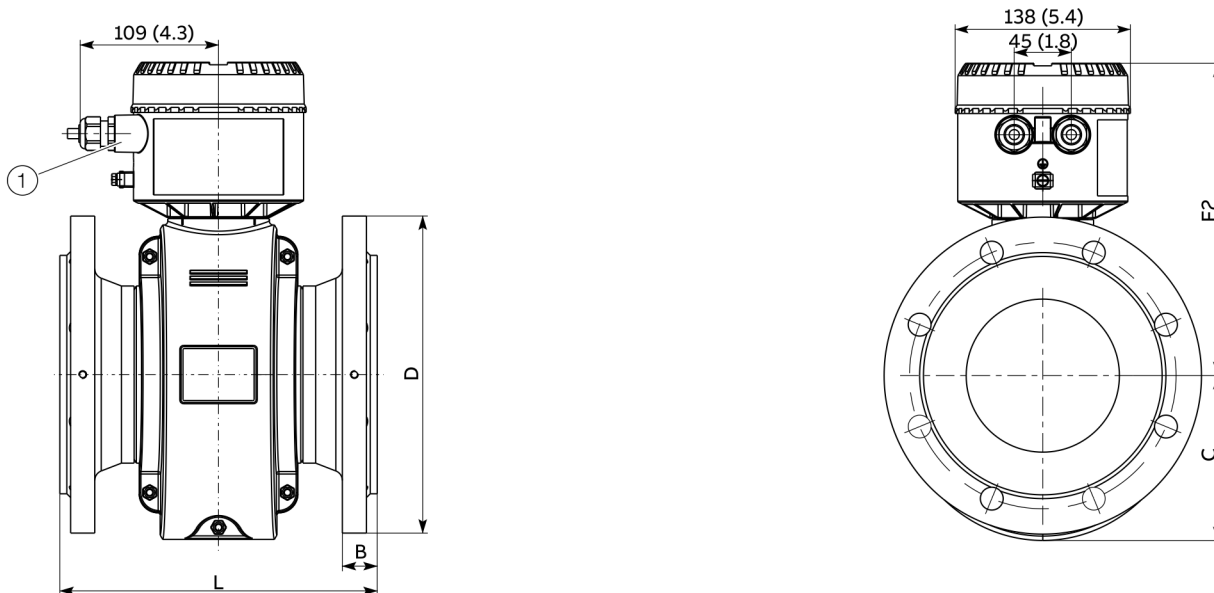

① Female thread (either 1/2” NPT or M20 x 1.5), see model coding. In the case of a 1/2” NPT, there is a plug instead of a PG cable entry.

Figure 15: Flange DN 3 to 100; sensor housing

Dimensions - flange device, aluminum sensor housing (shell housing)

Nominal diameter	Process connection	D	B	L ^{2,3}	C	F ⁷	F1 ⁷	F2 ⁷	Weight
DN 3 to 8 ⁴ (1/8 to 5/16” ⁵)	EN 1092-1 ⁶ , PN 10 to 40 ¹	90 (3.54)	19 (0.75)	200 (7.84)	82 (3.23)	255 (10.04)	269 (10.6)	191 (7.52)	5.5 (12)
	ASME B16.5, CL 150	90 (3.54)	14.2 (0.56)						
DN 10 (3/8” ⁵)	ASME B16.5, CL 300	95 (3.74)	17.3 (0.68)						
	JIS 10K	90 (3.54)	15 (0.59)						
DN 15 (1/2”)	EN 1092-1 ⁶ , PN 10 to 40 ¹	95 (3.74)	19 (0.75)	200 (7.84)	82 (3.23)	255 (10.04)	269 (10.6)	191 (7.52)	5.5 (12)
	ASME B16.5, CL 150	90 (3.54)	14.2 (0.56)						
	ASME B16.5, CL 300	95.2 (3.75)	17.3 (0.68)						
	JIS 10K	95 (3.74)	15 (0.59)						
DN 20 (3/4”)	EN 1092-1 ⁶ , PN 10 to 40 ¹	105 (4.13)	21 (0.83)	200 (7.84)	82 (3.23)	255 (10.04)	269 (10.6)	191 (7.52)	6.5 (14)
	ASME B16.5, CL 150	98.6 (3.88)	15.7 (0.62)						
	ASME B16.5, CL 300	117.3 (4.62)	18.7 (0.74)						
	JIS 10K	100 (3.94)	17 (0.67)						
DN 25 (1”)	EN 1092-1 ⁶ , PN 10 to 40 ¹	115 (4.53)	21 (0.83)	200 (7.84)	82 (3.23)	255 (10.04)	269 (10.6)	191 (7.52)	7.5 (16.5)
	ASME B16.5, CL 150	108 (4.25)	17.2 (0.68)						
	ASME B16.5, CL 300	124 (4.88)	20.5 (0.81)						
	JIS 10K	125 (4.92)	17 (0.67)						
DN 32 (1 1/4”)	EN 1092-1 ⁶ , PN 10 to 40 ¹	140 (5.51)	21 (0.83)	200 (7.84)	92 (3.62)	262 (10.3)	276 (10.87)	198 (7.80)	8.5 (18.5)
	ASME B16.5, CL 150	117.3 (4.62)	18.7 (0.74)						
	ASME B16.5, CL 300	133.4 (5.25)	22.1 (0.87)						
	JIS 10K	135 (5.31)	19 (0.75)						

Tolerance L: +0 / -3 mm (+0 / -0.018 in)

Dimensions – flange device, aluminum sensor housing (shell housing)

Nominal diameter	Process connection	D	B	L ^{2,3}	C	F ⁷	F1 ⁷	F2 ⁷	Weight
DN 40 (1 ½")	EN 1092-1 ⁶ , PN 10 to 40 ¹	150 (5.91)	21 (0.83)	200 (7.84)	92 (3.62)	262 (10.3)	276 (10.87)	198 (7.80)	9.5 (21)
	ASME B16.5, CL 150	127 (5.00)	20.5 (0.81)						
	ASME B16.5, CL 300	155.4 (6.12)	23.6 (0.93)						
	JIS 10K	140 (5.51)	19 (0.75)						
DN 50 (2")	EN 1092-1 ⁶ , PN 10 to 40 ¹	165 (6.50)	23 (0.91)	200 (7.87)	97.5 (3.84)	268 (10.55)	282 (11.1)	204 (8.0)	11 (24)
	ASME B16.5, CL 150	152.4 (6.00)	22.1 (0.87)						
	ASME B16.5, CL 300	165.1 (6.50)	25.4 (1.0)						
	JIS 10K	155 (6.10)	19 (0.75)						
	AS2129 table D, E	150 (5.91)	–						8.5 (18.5)
DN 65 (2 ½")	EN 1092-1 ⁶ , PN 16 ¹	185 (7.28)	22 (0.87)	200 (7.87)	108.5 (4.25)	279 (10.98)	293 (11.54)	215 (8.46)	11.5 (25)
	EN 1092-1 ⁶ , PN 40 ¹	185 (7.28)	26 (1.02)						13.5 (30)
	ASME B16.5, CL 150	177.8 (7.00)	25.4 (1.0)						11.5 (25)
	ASME B16.5, CL 300	190.5 (7.50)	28.4 (1.12)						13.5 (30)
	JIS 10K	175 (6.89)	21 (0.83)						13.5 (30)
	AS2129 table D, E	165 (6.50)	–						–
DN 80 (3")	EN 1092-1 ⁶ , N 10 to 40 ¹	200 (7.87)	28 (1.10)	200 (7.87)	108.5 (4.27)	279 (10.98)	293 (11.54)	215 (8.46)	15.5 (34)
	ASME B16.5, CL 150	190.5 (7.50)	26.9 (1.06)						15.5 (34)
	ASME B16.5, CL 300	210 (8.27)	31.4 (1.24)						17.5 (38.5)
	JIS 10K	185 (7.28)	21 (0.83)						17.5 (38.5)
	AS2129 table D, E	185 (7.28)	–						–
DN 100 (4")	EN 1092-1 ⁶ PN 16 ¹	220 (8.66)	24 (0.94)	250 (9.84)	122.5 (4.82)	301 (11.85)	315 (12.4)	237 (9.33)	17.5 (38.5)
	EN 1092-1 ⁶ PN 25 to 40 ¹	235 (9.25)	28 (1.10)						21.5 (47)
	ASME B16.5 CL 150	228.6 (9.00)	27.4 (1.08)						19.5 (43)
	ASME B16.5 CL 300	254 (10.0)	35.8 (1.41)						28.5 (63)
	JIS 10K	210 (8.72)	21 (0.83)						17.5 (38.5)
	AS2129 table D, E	215 (8.46)	–						–

1 Other pressure ratings on request.

2 If an grounding plate is fitted (fastened to one side of the flange), dimension L increases as follows: by 3 mm (0.118 in) for DN 3 to 100, and by 5 mm (0.197 in) for DN 125.

3 If protection plates are fitted (fastened to both sides of the flange), dimension L increases as follows: by 6 mm (0.236 in) for DN 3 to 100, and by 10 mm (0.394 in) for DN 125.

4 Connection flange DN 10.

5 Connection flange ½".

6 Connection dimensions in accordance with EN 1092-1. For DN 65, PN 16 in accordance with EN 1092-1 please order PN 40.

7 In devices with high temperature design, the dimensions F, F1 and F2 increase by +127 mm (+5.0 in).

... Model SE41F

Flange DN 125 to 400 (6 to 16”), aluminum sensor housing (shell housing)

All specified dimensions and weights are in mm (in) or kg (lb). The specified weights are approximate figures. The maximum weight is always provided.

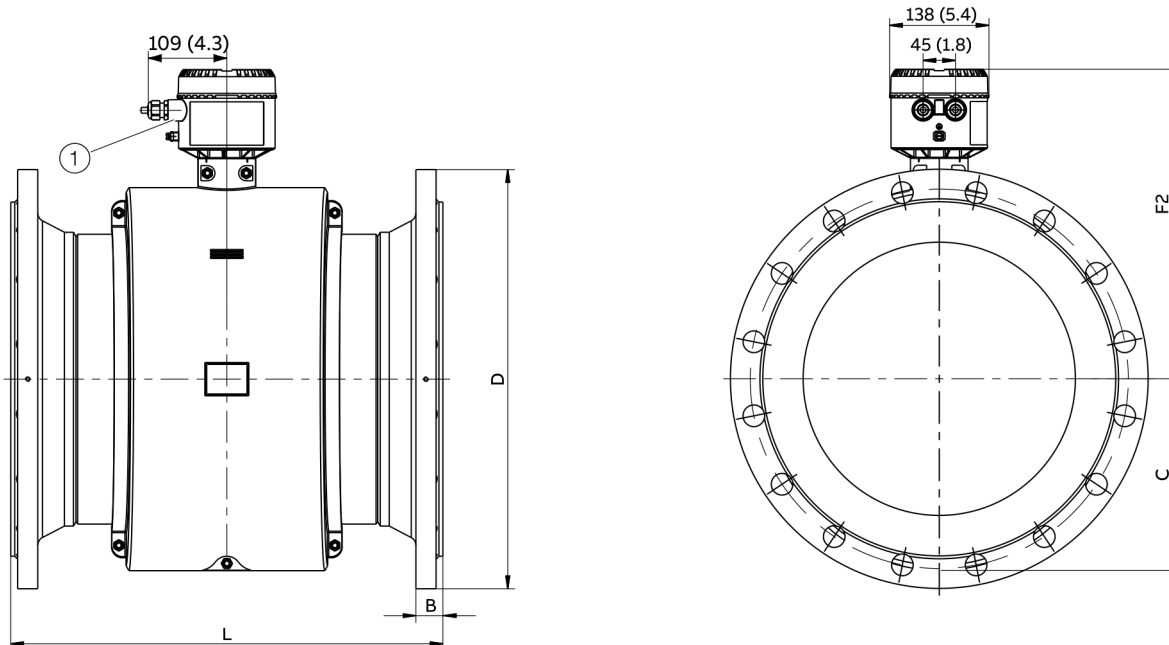

① Female thread (either 1/2” NPT or M20 x 1.5), see model coding. In the case of a 1/2” NPT, there is a plug instead of a PG cable entry.

Figure 16: Flange DN 125 to 400; sensor housing

Dimensions - flange device, aluminum sensor housing (shell housing)									
Nominal diameter	Process connection	D	B	L ^{2,3}	C	F ⁴	F1 ⁴	F2 ⁴	Weight
DN 125 (5")	EN 1092-1 ⁶ PN 16 ¹	250 (9.84)	25 (0.98)	250 (9.84)	130 (5.12)	311 (12.24)	325 (12.80)	247 (9.72)	20.5 (45)
	EN 1092-1 ⁶ PN 25 to 40 ¹	270 (10.63)	29 (1.14)						27.5 (60.5)
	ASME B16.5 CL 150	254 (10.0)	27.9 (1.10)						20.5 (45)
	ASME B16.5 CL 300	279.4 (11.0)	39.1 (1.54)	450 (17.72)					33.5 (74)
	JIS 10K	250 (9.84)	27 (1.06)	250 (9.84)					20.5 (45)
	AS2129 table D, E	255 (10.04)		—					—
DN 150 (6")	EN 1092-1 PN 16 ¹	285 (11.22)	25 (0.98)	300 (11.81)	146 (5.75)	358 (14.09)	372 (14.65)	294 (11.57)	31.5 (69.5)
	EN 1092-1 PN 25 to 40 ¹	300 (11.81)	31 (1.22)						37.5 (82.5)
	ASME B16.5 CL 150	279.4 (11.0)	29.4 (1.16)						31.5 (69.5)
	ASME B16.5 CL 300	317.5 (12.5)	40.5 (1.59)						45.5 (100)
	JIS 10K	280 (11.02)	28 (1.10)						31.5 (69.5)
	AS2129 table D, E	280 (11.02)		—					31.5 (69.5)
DN 200 (8")	EN 1092-1, PN 10 to 16 ¹	340 (13.39)	28 (1.10)	350 (13.78)	170.5 (6.71)	399 (15.71)	413 (16.26)	334 (13.15)	41.5 (90.5)
	EN 1092-1, PN 25 ¹	360 (14.17)	34 (1.34)						53.5 (118)
	EN 1092-1, PN 40 ¹	375 (14.76)	38 (1.50)						63.5 (151)
	ASME B16.5, CL 150	345 (13.58)	33.6 (1.32)						48.5 (107)
	ASME B16.5, CL 300	380 (14.96)	46.1 (1.81)						70.5 (155.5)
	JIS 10K	330 (12.99)	33 (1.30)						41.5 (90.5)
	AS2129 table D, E	335 (13.19)		—					48.5 (107)

Tolerance L: +0 / -3 mm (+0 / -0.018 in)

Dimensions – flange device, aluminum sensor housing (shell housing)

Nominal diameter	Process connection	D	B	L ^{2,3}	C	F ⁴	F1 ⁴	F2 ⁴	Weight
DN 250 (10")	EN 1092-1, PN 10 ¹	395 (15.55)	30 (1.18)	450 (17.72)	198 (7.80)	413 (16.26)	427 (16.81)	349 (13.74)	59.5 (131)
	EN 1092-1, PN 16 ¹	405 (15.94)	30 (1.18)						63.5 (140)
	EN 1092-1, PN 25 ¹	425 (16.73)	36 (1.42)						82.5 (182)
	EN 1092-1, PN 40 ¹	450 (17.72)	42 (1.65)						93.5 (206)
	ASME B16.5, CL 150	405 (15.94)	35.2 (1.39)						68.5 (151)
	ASME B16.5, CL 300	445 (17.52)	52.8 (2.08)						103.5 (228)
	JIS 10K	400 (15.75)	37 (1.46)						63.5 (140)
	AS2129 table D, E	405 (15.94)	—						68.5 (151)
DN 300 (12")	EN 1092-1, PN 10 ¹	445 (17.52)	31 (1.22)	500 (19.68)	228 (8.98)	436 (17.17)	450 (17.72)	372 (14.62)	72.5 (160)
	EN 1092-1, PN 16 ¹	460 (18.11)	33 (1.30)						78.5 (173)
	EN 1092-1, PN 25 ¹	485 (19.09)	39 (1.54)						98.5 (217)
	EN 1092-1, PN 40 ¹	515 (20.28)	47 (1.85)	600 (23.62)					138.5 (305)
	ASME B16.5, CL 150	485 (19.09)	36.8 (1.45)	500 (19.68)					103.5 (228)
	ASME B16.5, CL 300	520 (20.47)	55.8 (2.20)						148.5 (327)
	JIS 10K	450 (17.72)	40 (1.57)						78.5 (173)
	AS2129 table D, E	455 (17.19)	—						103.5 (228)
DN 350 (14")	EN 1092-1, PN 10 ¹	505 (19.88)	31 (1.22)	550 (21.65)	267 (10.51)	451 (17.76)	465 (18.31)	416 (16.38)	93.5 (206)
	EN 1092-1, PN 16 ¹	520 (20.47)	35 (1.38)						108.5 (239)
	EN 1092-1, PN 25 ¹	555 (21.85)	43 (1.69)						143.5 (316)
	ASME B16.5, CL 150	535 (21.06)	40.1 (1.58)						128.5 (283)
	ASME B16.5, CL 300	585 (23.03)	58.8 (2.31)						196.5 (433)
	JIS 10K	490 (19.29)	—						108.5 (239)
	AS2129 table D, E	525 (20.67)	—						103.5 (228)
	DN 400 (16")	EN 1092-1 PN 10 ¹	565 (22.24)	31 (1.22)	600 (23.62)	267 (10.51)	493 (19.41)	507 (19.96)	416 (16.38)
EN 1092-1 PN 16 ¹		580 (22.83)	37 (1.46)						124.5 (274)
EN 1092-1 PN 25 ¹		620 (24.41)	45 (1.77)						168.5 (371)
ASME B16.5 CL 150		595 (23.43)	41.6 (1.64)						173.5 (382)
ASME B16.5 CL 300		650 (25.59)	62.2 (2.45)						262.5 (579)
JIS 10K		560 (22.05)	—						124.5 (274)
AS2129 table D, E		580 (22.83)	—						173.5 (382)

1 Other pressure ratings on request.

2 If a grounding plate is fitted (fastened to one side of the flange), dimension L increases by 5 mm (0.197 in).

3 If protection plates are fitted (fastened to both sides of the flange), dimension L increases by 10 mm (0.394 in).

4 In devices with high temperature design, the dimensions F, F1 and F2 increase by +127 mm (+5.0 in).

Tolerance L: DN 150 to 200: +0 / -3 mm (+0 / -0.018 in), DN 250 to 400: +0 / -5 mm (+0 / -0.197 in)

... Model SE41F

Flange DN 450 to 600 (18 to 24"), steel sensor housing

All specified dimensions and weights are in mm (in) or kg (lb). The specified weights are approximate figures. The maximum weight is always provided.

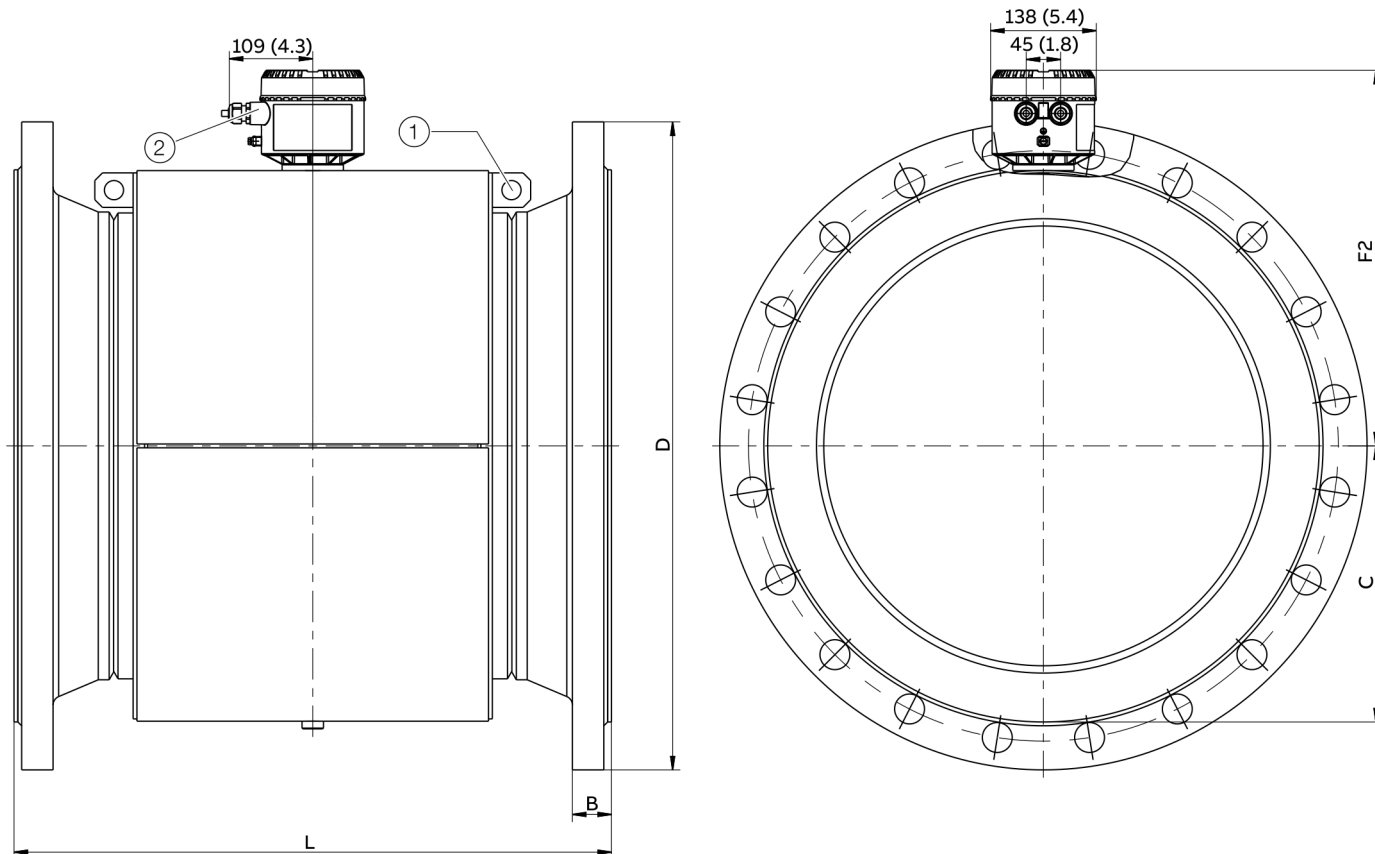

- ① Transport lugs
- ② Female thread (either 1/2" NPT or M20 x 1.5), see model coding. In the case of a 1/2" NPT, there is a plug instead of a PG cable entry.

Figure 17: Flange DN 450 to 2000; sensor housing

Dimensions - flange device, aluminum sensor housing (shell housing)										
Nominal diameter	Process connection	D	B	L ^{2,3}	C	F ⁴	F1 ⁴	F2 ⁴	Weight	
DN 450 (18")	ASME B16.5, CL 150	635 (25.0)	44.6 (1.76)	686 (27.01)	310 (12.20)	501 (19.72)	515 (20.28)	437 (17.20)	258.5 (570)	
	AS2129 table D, E	640 (25.20)	-	-	-	-	-	-	-	
DN 500 (20")	EN 1092-1, PN 10 ¹	670 (26.38)	33 (1.30)	650 (25.59)	310 (12.20)	501 (19.72)	515 (20.28)	437 (17.20)	188.5 (416)	
	EN 1092-1, PN 16 ¹	715 (28.15)	39 (1.54)	-	-	-	-	-	238.5 (526)	
	ASME B16.5, CL 150	698.5 (27.50)	47.9 (1.89)	762 (30.0)	-	-	-	-	298.5 (658)	
	AS2129 table D, E	705 (27.76)	-	650 (25.59)	-	-	-	-	-	
DN 600 (24")	EN 1092-1, PN 10 ¹	780 (30.71)	33 (1.30)	780 (30.71)	361 (14.21)	552 (21.73)	566 (22.28)	490 (19.29)	338.5 (746)	
	EN 1092-1, PN 16 ¹	840 (33.07)	41 (1.61)	-	-	-	-	-	316.5 (698)	
	ASME B16.5, CL 150	812.8 (32.0)	52.8 (2.08)	914 (35.98)	-	-	-	-	423.5 (934)	
	AS2129 table D, E	825 (32.48)	-	780 (30.71)	-	-	-	-	-	

- 1 Other pressure ratings on request.
 - 2 If a grounding plate is fitted (fastened to one side of the flange), dimension L increases by 5 mm (0.197 in).
 - 3 If protection plates are fitted (fastened to both sides of the flange), dimension L increases by 10 mm (0.394 in).
 - 4 In devices with high temperature design, the dimensions F, F1 and F2 increase by +127 mm (+5.0 in).
- Tolerance for L: DN 450, DN 500 +0 / -5 mm (+0 / -0.197 in); DN 600 +0 / -10 mm (+0 / -0.394 in)

Flange DN 700 to 1000 (28 to 40”), steel sensor housing

All specified dimensions and weights are in mm (in) or kg (lb). The specified weights are approximate figures. The maximum weight is always provided.

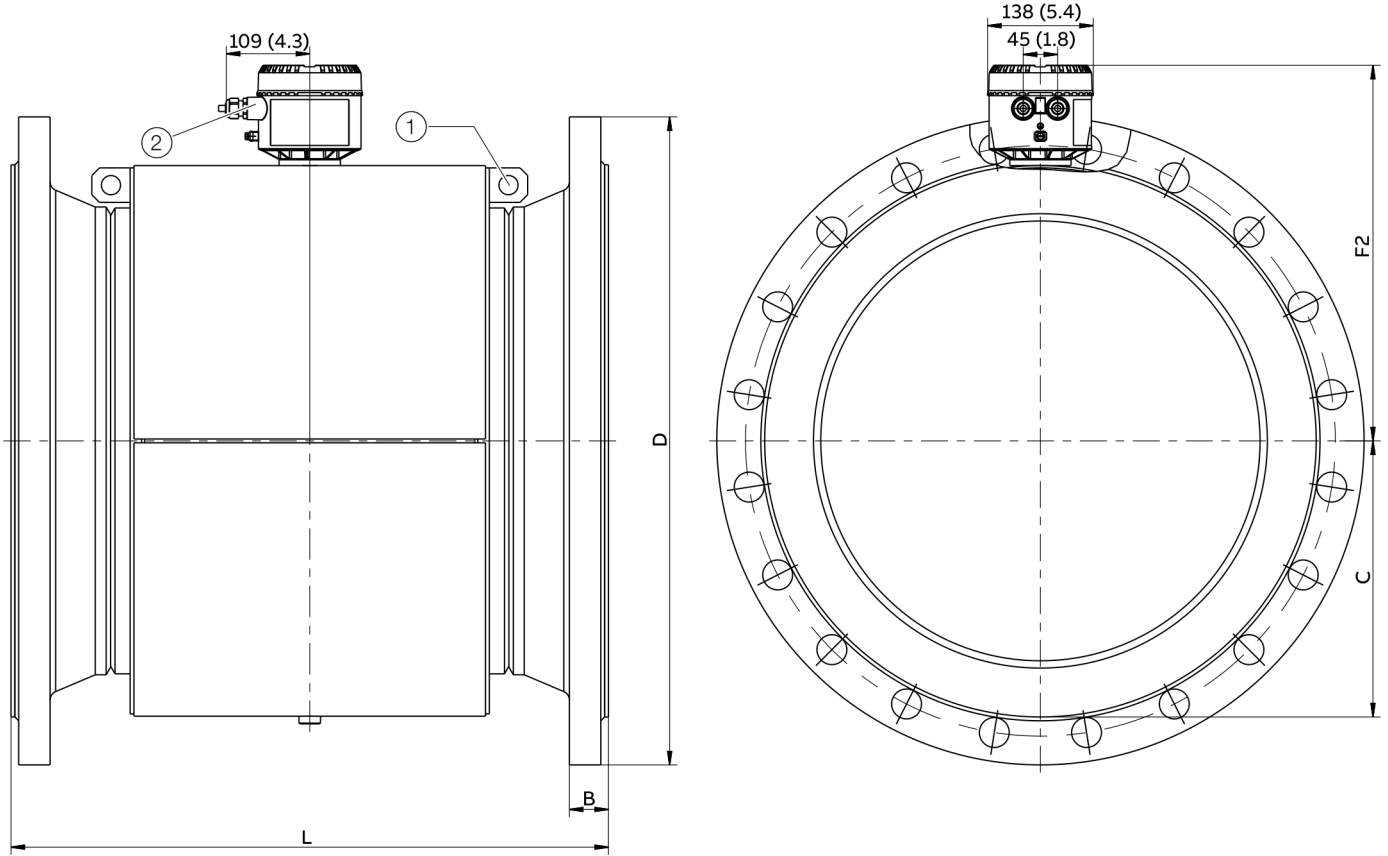

Remote mount design

- ① Transport lugs
- ② Female thread (either ½” NPT or M20 x 1.5), see model coding. In the case of a ½” NPT, there is a plug instead of a PG cable entry.

Figure 18: Flange DN 700 to 1000; sensor housing

Dimensions – flange device, aluminum sensor housing (shell housing)									
Nominal diameter	Process connection	D	B	L ^{2,3}	C	F ⁴	F1 ⁴	F2 ⁴	Weight
DN 700 (28”)	EN 1092-1, PN 10 ¹	895 (35.24)	35 (1.38)	910 (35.83)	405 (15.94)	596 (23.46)	610 (24.02)	534 (21.02)	318.5 (702)
	EN 1092-1, PN 16 ¹	910 (35.83)	36 (1.42)						438.5 (967)
	ASME B16.47, CL 150	836.7 (32.94)	49.5 (1.95)						348.5 (768)
DN 800 (32”)	EN 1092-1, PN 10 ¹	1015 (39.96)	37 (1.46)	1040 (40.94)	455 (17.91)	646 (25.43)	660 (25.98)	584 (22.99)	418.5 (923)
	EN 1092-1, PN 16 ¹	1025 (40.35)	43 (1.69)						488.5 (1077)
	ASME B16.47, CL 150	942 (37.09)	51 (2.01)						498.5 (1099)
DN 900 (36”)	EN 1092-1, PN 10 ¹	1115 (43.90)	39 (1.54)	1170 (46.06)	505 (19.88)	696 (27.40)	710 (27.95)	635 (25.0)	503.5 (1110)
	EN 1092-1, PN 16 ¹	1125 (44.29)	45 (1.77)						588.5 (1297)
	ASME B16.47, CL 150	1157.1 (41.62)	57.3 (2.26)						678.5 (1496)
DN 1000 (40”)	EN 1092-1, PN 10 ¹	1230 (48.43)	39 (1.54)	1300 (51.18)	555 (21.85)	746 (29.37)	760 (29.92)	685 (26.97)	688.5 (1517)
	EN 1092-1, PN 16 ¹	1255 (49.41)	47 (1.85)						848.5 (1870)
	ASME B16.47, CL 150	1174.8 (46.25)	60.6 (2.39)						878.5 (1937)

- 1 Other pressure ratings on request.
 - 2 If a grounding plate is fitted (fastened to one side of the flange), dimension L increases by 5 mm (0.197 in).
 - 3 If protection plates are fitted (fastened to both sides of the flange), dimension L increases by 10 mm (0.394 in).
 - 4 In devices with high temperature design, the dimensions F, F1 and F2 increase by +127 mm (+5.0 in).
- Tolerance for L: DN 700 to 1000 +0 / -10 mm (+0 / -0.394 in)

... Model SE41F

Flange DN 25 to 200 (1 to 8”), high pressure design, aluminum sensor housing (shell housing)

All specified dimensions and weights are in mm (in) or kg (lb). The specified weights are approximate figures. The maximum weight is always provided.

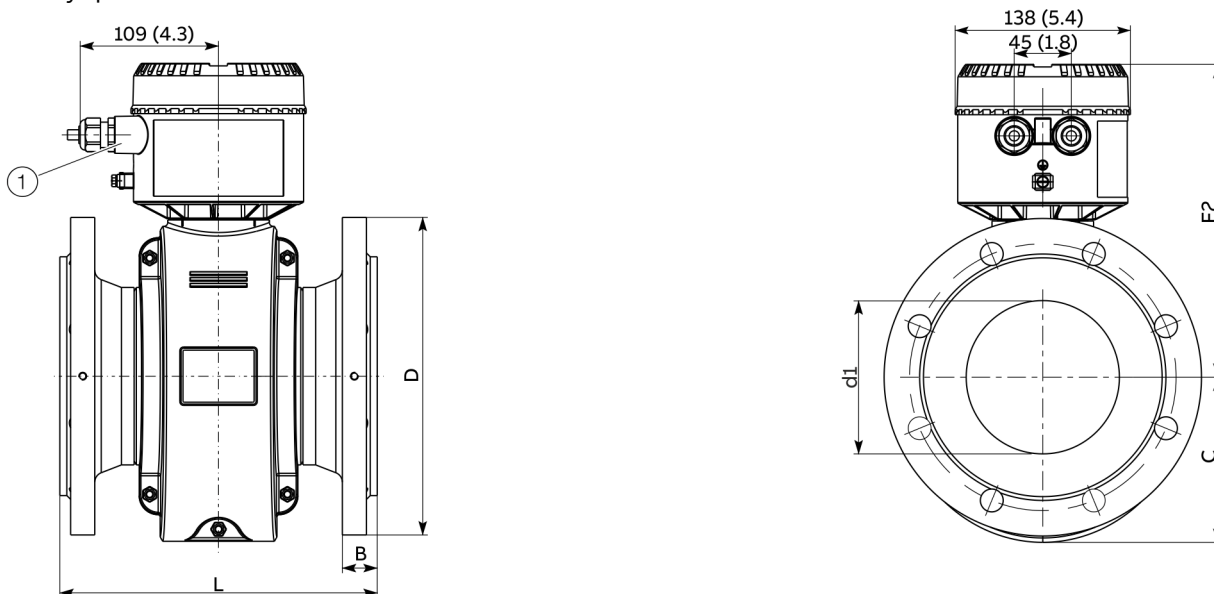

① Female thread (either 1/2” NPT or M20 x 1.5), see model coding. In the case of a 1/2” NPT, there is a plug instead of a PG cable entry.

Figure 19: Flange DN 25 to 200; sensor housing

Dimensions - flange device, aluminum sensor housing (shell housing)											
DN	Process connection	D	di	Plan	L ^{1,2}	F	C	F1	F2	A	Weight
25 (1")	EN1092-1 PN63	140	22	—	270						10 (22)
	EN1092-1 PN100	(5.51)	(0.87)		(10.63)	255	82	269	191	113	
	ASME B16.5, CL 600	124	22	40	270	(10.04)	(3.23)	(10.6)	(7.52)	(4.45)	10 (22)
		(4.88)	(0.87)	(1.57)	(10.63)						
40 (1½")	EN1092-1 PN63	170	36	—	280						11 / 12
	EN1092-1 PN100	(6.69)	(1.42)		(11.02)	262	92	276	198	113	(24 / 27)
	ASME B16.5, CL 600	156	35	40	280	(10.31)	(3.62)	(10.87)	(7.80)	(4.45)	11
		(6.14)	(1.38)	(1.57)	(11.02)						(24)
50 (2")	EN1092-1 PN63	180	48	—	280						13
	EN1092-1 PN100	(7.09)	(1.89)		(11.02)						(29)
	ASME B16.5, CL 600	195	48	—	280	268	97	282	204	115	16
		(7.68)	(1.89)		(11.02)	(10.55)	(3.82)	(11.1)	(8.0)	(4.53)	(35)
	ASME B16.5, CL 600	165	46	40	280						13
		(6.50)	(1.81)	(1.57)	(11.02)						(29)
65 (2½")	EN1092-1 PN63	205	64	--	330						16
	EN1092-1 PN100	(8.07)	(2.52)		(12.99)						(35)
	ASME B16.5, CL 600	220	63	--	330	279	108	293	215	104	21
		(8.66)	(2.48)		(12.99)	(10.98)	(4.25)	(11.54)	(8.46)	(4.09)	(46)
	ASME B16.5, CL 600	190	60	30	330						18
		(7.48)	(2.36)		(12.99)						(40)

Dimensions - flange device, aluminum sensor housing (shell housing)											
DN	Process connection	D	di	Plan	L^{1,2}	F	C	F1	F2	A	Weight
80 (3")	EN1092-1 PN63	215 (8.46)	76 (2.99)	--	340 (13.39)						20 (44)
	EN1092-1 PN100	230 (9.06)	75 (2.95)	--	340 (13.39)	279 (10.98)	108 (4.25)	293 (11.54)	215 (8.46)	104 (4.09)	24 (53)
	ASME B16,5, CL 600	209 (8.23)	72 (2.83)	40	340 (13.39)						23 (51)
100 (4")	EN1092-1 PN63	250 (9.84)	100 (3.94)	--	400 (15.75)						27 (60)
	EN1092-1 PN100	265 (10.43)	98 (3.85)	--	400 (15.75)	301 (11.85)	122 (4.8)	315 (12.4)	237 (9.33)	125 (4.92)	26 (57)
	ASME B16,5, CL 600	273 (10.75)	91 (3.58)	80	400 (15.75)						44 (97)
125 (5")	EN1092-1 PN63	295 (11.61)	124 (4.88)	--	450 (17.72)	311 (12.24)	130 (5.12)	325 (12.80)	247 (9.72)	125 (4.92)	68 (150)
	EN1092-1 PN100	315 (12.4)	121 (4.76)	--	450 (17.72)						68 (150)
	ASME B16,5, CL 600	330 (12.99)	116 (4.56)	80	400 (15.75)						68 (150)
150 (6")	EN1092-1 PN63	345 (13.58)	151 (5.94)	--	450 (17.72)						92 (203)
	EN1092-1 PN100	355 (13.98)	148 (5.83)	--	450 (17.72)	358 (14.09)	146 (5.75)	372 (14.65)	294 (11.57)	166 (6.54)	92 (203)
	ASME B16,5, CL 600	355 (13.98)	140 (5.51)	80	450 (17.72)						92 (203)
200 (8")	EN1092-1 PN63	415 (16.34)	199 (7.83)	—	500 (19.68)						148 (326)
	EN1092-1 PN100	430 (16.93)	193 (7.60)	—	500 (19.68)	399 (15.71)	170 (6.69)	413 (16.26)	334 (13.15)	200 (7.78)	148 (326)
	ASME B16,5, CL 600	419 (16.50)	188 (7.40)	80	500 (19.68)						148 (326)

1 If a grounding plate is fitted (fastened to one side of the flange), dimension L increases as follows: by 3 mm for DN 3 ... 100, and by 5 mm for DN 125.

2 If protection plates are fitted (fastened to both sides of the flange), dimension L increases as follows: by 6 mm for DN 3 ... 100, and by 10 mm for DN 125.

Tolerance for L: DN 25 to 100 +0 / -5 mm, DN 150 to 200 +0 / -5 mm

Tolerance Di: hard rubber: +1 / -3 mm

All nominal pressures (PN63, PN100, CL600) are available with hard rubber only

... Model SE41F

Ordering information

FSM4000 SE41F with welded Flange, Liner Material Thick-PTFE / PTFE / PFA / ETFE

Main order number																				
Electromagnetic Flowmeter FSM4000	SE41F-XXX	X	X	X	X	X	X	X	X	X	X	X	X	X	X	X	X	X	XXX	XXX
Liner Material / Meter Size																				
PFA / DN 3 (1/10 in)	P03																			
PFA / DN 4 (5/32 in)	P04																			
PFA / DN 6 (1/4 in)	P06																			
PFA / DN 8 (5/16 in)	P08																			
PFA / DN 10 (3/8 in)	P10																			
PFA / DN 15 (1/2 in)	P15																			
PFA / DN 20 (3/4 in)	P20																			
PFA / DN 25 (1 in)	P25																			
PFA / DN 32 (1-1/4 in)	P32																			
PFA / DN 40 (1-1/2 in)	P40																			
PFA / DN 50 (2 in)	P50																			
PFA / DN 65 (2-1/2 in)	P65																			
PFA / DN 80 (3 in)	P80																			
PFA / DN 100 (4 in)	P1H																			
PFA / DN 125 (5 in)	P1Q																			
PFA / DN 150 (6 in)	P1F																			
PFA / DN 200 (8 in)	P2H																			
PTFE / DN 10 (3/8 in)	T10																			
PTFE / DN 15 (1/2 in)	T15																			
PTFE / DN 20 (3/4 in)	T20																			
PTFE / DN 25 (1 in)	T25																			
PTFE / DN 32 (1-1/4 in)	T32																			
PTFE / DN 40 (1-1/2 in)	T40																			
PTFE / DN 50 (2 in)	T50																			
PTFE / DN 65 (2-1/2 in)	T65																			
PTFE / DN 80 (3 in)	T80																			
PTFE / DN 100 (4 in)	T1H																			
PTFE / DN 125 (5 in)	T1Q																			
PTFE / DN 150 (6 in)	T1F																			
PTFE / DN 200 (8 in)	T2H																			
PTFE / DN 250 (10 in)	T2F																			
PTFE / DN 300 (12 in)	T3H																			
PTFE / DN 350 (14 in)	T3F																			
PTFE / DN 400 (16 in)	T4H																			
PTFE / DN 450 (18 in)	T4F																			
PTFE / DN 500 (20 in)	T5H																			
PTFE / DN 600 (24 in)	T6H																			
Thick PTFE / DN 25 (1 in)	F25																			
Thick PTFE / DN 32 (1-1/4 in)	F32																			
Thick PTFE / DN 40 (1-1/2 in)	F40																			
Thick PTFE / DN 50 (2 in)	F50																			
Thick PTFE / DN 65 (2-1/2 in)	F65																			
Thick PTFE / DN 80 (3 in)	F80																			
Thick PTFE / DN 100 (4 in)	F1H																			
Thick PTFE / DN 125 (5 in)	F1Q																			
Thick PTFE / DN 150 (6 in)	F1F																			

Continued on next page

Main order number																		
Electromagnetic Flowmeter FSM4000	SE41F- XXX	X	X	X	X	X	X	X	X	X	X	X	X	X	X	X	XXX	XXX
Liner Material / Meter Size																		
Thick PTFE / DN 200 (8 in)	F2H																	
Thick PTFE / DN 250 (10 in)	F2F																	
Thick PTFE / DN 300 (12 in)	F3H																	
ETFE / DN 25 (1 in)	E25																	
ETFE / DN 32 (1-1/4 in)	E32																	
ETFE / DN 40 (1-1/4 in)	E40																	
ETFE / DN 50 (2 in)	E50																	
ETFE / DN 65 (2-1/2 in)	E65																	
ETFE / DN 80 (3 in)	E80																	
ETFE / DN 100 (4 in)	E1H																	
ETFE / DN 125 (5 in)	E1Q																	
ETFE / DN 150 (6 in)	E1F																	
ETFE / DN 200 (8 in)	E2H																	
ETFE / DN 250 (10 in)	E2F																	
ETFE / DN 300 (12 in)	E3H																	
ETFE / DN 350 (14 in)	E3F																	
ETFE / DN 400 (16 in)	E4H																	
ETFE / DN 450 (18 in)	E4F																	
ETFE / DN 500 (20 in)	E5H																	
ETFE / DN 600 (24 in)	E6H																	
ETFE / DN 700 (28 in)	E7H																	
ETFE / DN 800 (32 in)	E8H																	
ETFE / DN 900 (36 in)	E9H																	
ETFE / DN 1000 (40 in)	E1T																	
Others / DN 3 (1/10 in)	Z03																	
Others / DN 4 (5/32 in)	Z04																	
Others / DN 6 (1/4 in)	Z06																	
Others / DN 8 (5/16 in)	Z08																	
Others / DN 10 (3/8 in)	Z10																	
Others / DN 15 (1/2 in)	Z15																	
Others / DN 20 (3/4 in)	Z20																	
Others / DN 25 (1 in)	Z25																	
Others / DN 32 (1-1/4 in)	Z32																	
Others / DN 40 (1-1/2 in)	Z40																	
Others / DN 50 (2 in)	Z50																	
Others / DN 65 (2-1/2 in)	Z65																	
Others / DN 80 (3 in)	Z80																	
Others / DN 100 (4 in)	Z1H																	
Others / DN 125 (5 in)	Z1Q																	
Others / DN 150 (6 in)	Z1F																	
Others / DN 200 (8 in)	Z2H																	
Others / DN 250 (10 in)	Z2F																	
Others / DN 300 (12 in)	Z3H																	
Others / DN 350 (14 in)	Z3F																	
Others / DN 400 (16 in)	Z4H																	
Others / DN 450 (18 in)	Z4F																	
Others / DN 500 (20 in)	Z5H																	
Others / DN 600 (24 in)	Z6H																	

Continued on next page

... Model SE41F

Main order number															
Electromagnetic Flowmeter FSM4000				SE41F-	XXX	X	X	X	X	X	X	X	X	XXX	XXX
Measuring Electrodes Material / Grounding Electrodes															
Hastelloy C-4 (2.4610) / Without						H									
Hastelloy B-3 (2.4600) / Without						B									
AISI 316Ti SST (1.4571) / Without						S									
Titanium / Without						M									
Tantalum / Without						T									
AISI 904L SST (1.4539) / Without						F									
Platinum-Iridium / Without						P									
Nickel / Without						U ⁴⁾									
Double Layer / Without						C ¹⁾									
Tungsten-Carbide / Without						K ¹⁾									
Hastelloy C-4 (2.4610) / With						O ³⁾									
Hastelloy B-3 (2.4600) / With						N ³⁾									
AISI 316Ti SST (1.4571) / With						E ³⁾									
Titanium / With						I ³⁾									
Tantalum / With						Q ³⁾									
AISI 904L SST (1.4539) / With						R ³⁾									
Platinum-Iridium / With						G ³⁾									
Nickel / With						V ⁵⁾									
Double Layer / With						D ²⁾									
Pressure Rating															
PN 10, ISO lay length						C									
PN 16, ISO lay length						D ⁶⁾									
PN 25, ISO lay length						E									
PN 40, ISO lay length						F ⁷⁾									
JIS 10K, ISO lay length						K ⁸⁾									
ASME CL 150, ISO lay length						R									
ASME CL 300, ISO lay length						S ⁹⁾									
Others						Z									
Material of Process Connection															
Steel						1 ¹⁰⁾									
Stainless steel						3 ¹¹⁾									
Accessories															
Without						A									
Protection rings AISI 316Ti SST (1.4571)						B ¹²⁾									
Grounding ring AISI 316Ti SST (1.4571)						C ¹²⁾									
Others						Z									
Temperature Range															
Standard design (<= 130 °C [266 °F])						S									
High temperature design (<= 180 °C [356 °F])						H ¹³⁾									

1) Basic material Hastelloy C-4

2) Basic material Hastelloy C-4 / Grounding electrodes <= DN 400 (16 in)

3) Grounding electrodes <= DN 400 (16 in)

4) ≥ DN 25 (1 in)

5) >= DN 25 (1 in) / Grounding electrodes <= DN 400 (16 in)

6) DN 65 (2-1/2 in) / PN 16 with connection dimensions acc. EN 1092-1:
Please order PN 40

7) Standard for DN 3 ... DN 80 (1/10 ... 3 in)

Continued on next page

8) <= DN 300 (12 in)

9) <= DN 400 (16 in)

10) >= DN 20 (3/4 in)

11) Standard for DN 3 ... DN 15 (1/10 ... 1/2 in), option from DN 20 (3/4 in)

12) Protection rings mounted on both sides and ground rings mounted on
one side to flange

13) Only with Thick-PTFE / PFA >= DN 25 (1 in)

Main order number																									
Electromagnetic Flowmeter FSM4000										SE41F-	XXX	X	X	X	X	X	X	X	X	X	X	X	XXX	XXX	
Certificates																									
PED Standard										A															
Material certificate 3.1 acc. EN 10204 with pressure test acc. AD2000										D ¹⁴⁾															
Pressure test acc. AD2000										G															
Inspection certificate 3.1 acc. EN 10204										F															
Calibration Certificates																									
Standard										A															
Fingerprint saved at factory										F ¹⁵⁾															
Schutzart / Kabelzuführung																									
IP 67 / Thread for screw-type conduit fitting M20 x 1.5												2													
IP 67 / Thread for screw-type conduit fitting NPT 1/2 in												4													
IP 68 / Thread for screw-type conduit fitting M20 x 1.5												7 ¹⁶⁾													
IP 68 / Cable connected and connection box potted												8													
IP 68 / Cable connected and connection box potted NPT 1/2 in												A													
Design																									
Without pre-amplifier												1 ¹⁷⁾													
With pre-amplifier type A												2 ¹⁸⁾													
With pre-amplifier type B												4 ¹⁹⁾													
Name Plate Language / Type																									
German / Adhesive foil														G											
English / Adhesive foil														E											
French / Adhesive foil														F											
German / Stainless steel														J											
English / Stainless steel														K											
French / Stainless steel														L											
Design Level																									
(Specified by ABB)														x											
Lay Length																									
Short, acc. ISO 13359																A									
Electrode Design																									
Standard																1									
Conical head, AISI 904L SST (1.4539)																2 ²⁰⁾									
Swedish design, Hastelloy C-4 (2.4610)																3 ²¹⁾									

14) Material certificate for meter tube and flanges

15) > DN8 (5/16 in)

16) Sealing compound (optional): D141B038U01

17) From DN 10 (3/8 in) >= 20 µS/cm

18) Standard up to DN 8 (5/16 in) >= 20 µS/cm, option > DN 8 (5/16 in) >= 5 µS/cm and cable length max. 200 m (660 ft)

19) Option: Up to DN 8 (5/16 in) >= 5 µS/cm, > DN 8 (5/16 in) >= 0.5 µS/cm and cable length max. 200 m (660 ft)

20) For application e.g. with high fat contents

21) DN 50 ... DN 400 (2 ... 16 in), for pulp applications with high resin contents

Continued on next page

... Model SE41F

Main order number																										
Electromagnetic Flowmeter FSM4000											SE41F-	XXX	X	X	X	X	X	X	X	X	X	X	X	X	XXX	XXX
Signal Cable Length																										
Without cable																		000								
5 m (16 ft)																		005								
10 m (33 ft)																		010								
20 m (66 ft)																		020								
30 m (100 ft)																		030								
40 m (131 ft)																		040								
50 m (164 ft)																		050								
60 m (197 ft)																		060								
70 m (230 ft)																		070								
80 m (262 ft)																		080								
90 m (295 ft)																		090								
100 m (328 ft)																		100								
125 m (410 ft)																		125								
150 m (490 ft)																		150								
175 m (570 ft)																		175								
200 m (660 ft)																		200								
Excitation Cable Length																										
Without cable																		000								
5 m (16 ft)																		005								
10 m (33 ft)																		010								
20 m (66 ft)																		020								
30 m (100 ft)																		030								
40 m (131 ft)																		040								
50 m (164 ft)																		050								
60 m (197 ft)																		060								
70 m (230 ft)																		070								
80 m (262 ft)																		080								
90 m (295 ft)																		090								
100 m (328 ft)																		100								
125 m (410 ft)																		125								
150 m (490 ft)																		150								
175 m (570 ft)																		175								
200 m (660 ft)																		200								

Continued on next page

Additional order number

Additional order number			
Electromagnetic Flowmeter FSM4000 SE41F-	XX	XX	XXX
Calibration			
2 points (standard)	VK		
3 point standard calibration	VC		
Witnessed calibration, 5 calibration points	VE ²²⁾		
5 point calibration acc. ISO17025	VD ²²⁾		
Language of Documentation			
German			M1
English			M5
Russian			MB
Language package Western Europe / Scandinavia (Languages: FR, ES, DA, IT, NL, PT, SV, FI)			MW
Language package Eastern Europe (Languages: EL, CS, ET, HU, HR, LT, LV, PL, SK, SL, RO, BG)			ME
Others			MZ
Other Usage Certifications			
Russia - metrological and EAC certificate			ED1
22) Only available with FSM4000-S4 External Converter			

Model SE21_

Specifications

Minimum permissible absolute pressure

Liner	Nominal diameter DN	P _{Operation} mbar abs	at	T _{Operation} ¹⁾ °C
PFA	3 to 100 (1/10 to 4")	0	≤	130 °C (266 °F)

1) For CIP/SIP cleaning, higher temperatures are permitted for limited time periods; refer to the table entitled 'Maximum permissible cleaning temperature'.

Maximum permissible cleaning temperature

CIP cleaning	Liner	T _{max} °C	T _{max} Minutes	T _{amb.} °C
Steam cleaning	PFA	150 °C (302 °F)	60	25 °C (77 °F)
Wet cleaning	PFA	140 °C (284 °F)	60	25 °C (77 °F)

If the ambient temperature is > 25 °C (77 °F), then the difference must be subtracted from the max. cleaning temperature.

$$T_{\max} - \Delta \text{ °C}, \Delta \text{ °C} = (T_{\text{amb}} - 25 \text{ °C})$$

Maximum Allowable Temperature Shock

Lining	Temp shock max. temp. diff. °C	Temp. gradient °C/min diff. °C
PFA	Any	Any

Maximum permissible ambient temperature as a function of measuring medium temperature

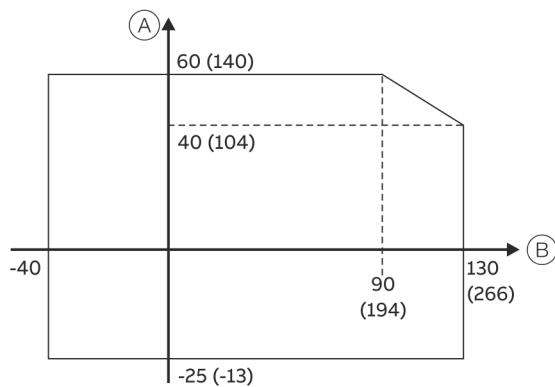

(A) Ambient temperature T_{amb.}

(B) Measuring medium temperature T_{medium}

Figure 20: Temperature graph

Sensor material

Liner	Electrode material		Electrode design	
	Standard	Others	Standard	Others
PFA	Hast.-C4 (2.4610) (1.4539 [904 L] for pipe conn. and Tri-Clamp)	Hast.-B3 (2.4600), 1.4539 (904 L), 1.4571 (316 Ti), Titanium, tantalum, platinum- iridium	Flat head	Pointed head (≥ DN 10) 1.4539 (904 L)

1/8" sanitary connectors always with 2 grounding electrodes in the same material as measuring electrodes, standard.

Process connection material

Process connection	Standard
Flange	Stainless steel 1.4571 (316 Ti)
Wafer type	without
Welded spuds	Stainless steel 1.4404 (316 L)
Pipe fitting	Stainless steel 1.4404 (316 L)
Tri-Clamp	Stainless steel 1.4404 (316 L)
External threads	Stainless steel 1.4404 (316 L)
Terminal box	
• without/with preamplifier, type A	Stainless steel 1.4301 (304)
• with preamplifier, type B	Aluminum alloy, painted, paint coat frame: dark gray, RAL 7012 cover: light gray, RAL 9002
Meter tube	Stainless steel 1.4301 (304)
Cable gland	Polyamide
Flowmeter sensor housing	Stainless steel 1.4301 (304)

Gasket material (internal)

Process connection	Standard	Option
Wafer type	without	—
Welded spuds	EPDM (Ethylene-Propylene) with FDA approval, silicone with FDA approval (CIP-resistant, no oils or grease)	Silicon with FDA approval (optional, resistant to oils and grease)
Pipe fitting	EPDM (Ethylene-Propylene) with FDA approval, silicone with FDA approval (CIP-resistant, no oils or grease)	PTFE with FDA approval (DN 3 to 8)
Tri-Clamp	EPDM (Ethylene-Propylene) with FDA approval, silicone with FDA approval (CIP-resistant, no oils or grease)	PTFE with FDA approval (DN 3 to 8)
External threads	EPDM (Ethylene-Propylene) with FDA approval, silicone with FDA approval (CIP-resistant, no oils or grease)	PTFE with FDA approval (DN 3 to 8)
Flat gaskets	Silicon (resistant to oil, grease)	—

Storage temperature

-25 to 70 °C (-13 to 158 °F)

IP rating in accordance with EN 60529

- IP 67
- IP 68 (Option)

Pipe vibration according to EN 60068-2-6

Transmitter

- In the range of 10 to 55 Hz, max. deflection 0.15 mm

Sensor

- In the range of 10 to 55 Hz, max. deflection 0.15 mm
- In the range of 10 to 55 Hz, max. acceleration 2 g

Material loads for process connections

Limits for allowable fluid temperature (TS) and allowable pressure (PS) are a function of the liner and flange material used (see the factory tag and name plate of the unit).

Devices with variable process connections / wafer type SE21 DN 3 to 100 (1/10 to 4")

Process connection	Nominal diameter DN	PS _{max} [bar]	TS _{min}	TS _{max}
PFA liner				
Wafer type	3 to 50 (1/10 to 2")	40	-40 °C (-40 °F)	130 °C (266 °F)
	65 to 100 (2 1/2 to 4")	16		
Welded spuds	3 to 40 (1/10 to 1 1/2")	40	-25 °C (-13 °F)	130 °C (266 °F)
	50; 80 (2", 3")	16		
	65, 100 (2 1/2 to 4")	10		
Threaded pipe connection conforming to DIN 11851	3 to 40 (1/10 to 1 1/2")	40	-25 °C (-13 °F)	130 °C (266 °F)
	50; 80 (2", 3")	16		
	65, 100 (2 1/2 to 4")	10		
Tri-Clamp conforming to DIN 32676	3 to 50 (1/10 to 2")	16	-25 °C (-13 °F)	121 °C (250 °F)
	65 to 100 (2 1/2 to 4")	10		
Tri-Clamp in acc. with ASME BPE	3 to 100 (1/10 to 4")	10	-25 °C (-13 °F)	130 °C (266 °F)
External threads	3 to 25 (1/10 to 1")	16	-25 °C (-13 °F)	130 °C (266 °F)
ISO 228				

JIS B2210-10K wafer type

Nominal diameter DN	Material	PN	TS	PS [bar]
32 to 100 (1 1/4 to 4")	1.4404 (316 L), 1.4435 (316 L), 1.4301 (304)	10	-40 to 130 °C (-40 to 266 °F)	10

Material load for flange design model SE21F

Liner: PFA

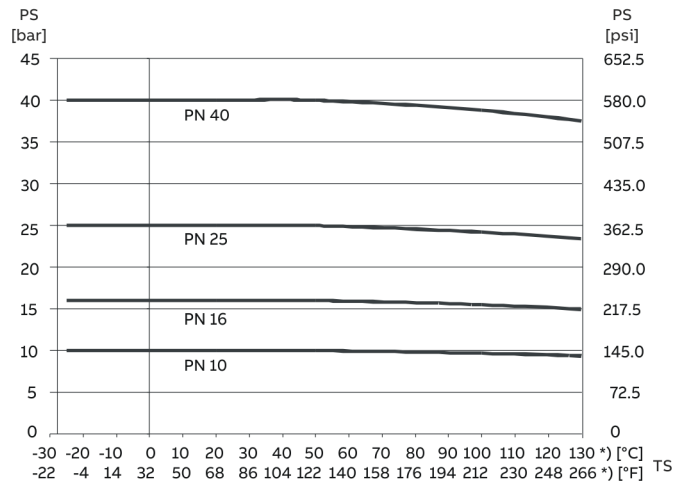

Figure 21: DIN flange, stainless steel 1.4571 (316 Ti) up to DN 100 (4")

*) Higher temperatures are allowed for CIP/SIP cleaning for limited time periods, see Table 'Maximum permissible cleaning temperature'.

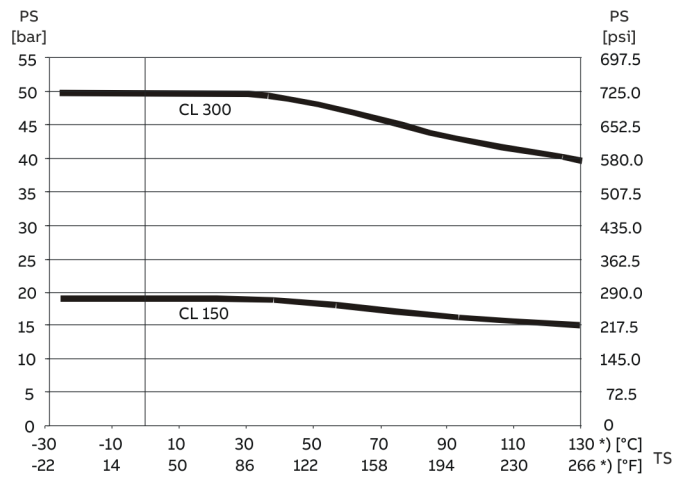

Figure 22: ASME flange, stainless steel 1.4571 (316 Ti) up to DN 100 (4")

*) Higher temperatures are allowed for CIP/SIP cleaning for limited time periods, see Table 'Maximum permissible cleaning temperature'.

... Model SE21_

Material load for wafer type design model SE21W

Liner: PFA wafer type

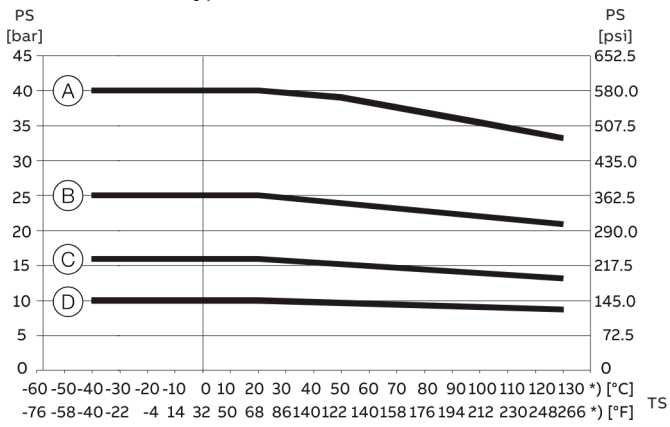

- (A) PN 40/CL 300 (C) PN 16/CL 150
- (B) PN 25 (D) PN 10

Figure 23: Wafer type design model SE21W

*) Higher temperatures are allowed for CIP/SIP cleaning for limited time periods, see Table 'Maximum permissible cleaning temperature'.

Dimensions

Model SE21F

Stainless steel housing, flange according to DIN / EN 1092-1, DN 3 to DN 40; ASME B16.5, 1/10 to 1 1/2"

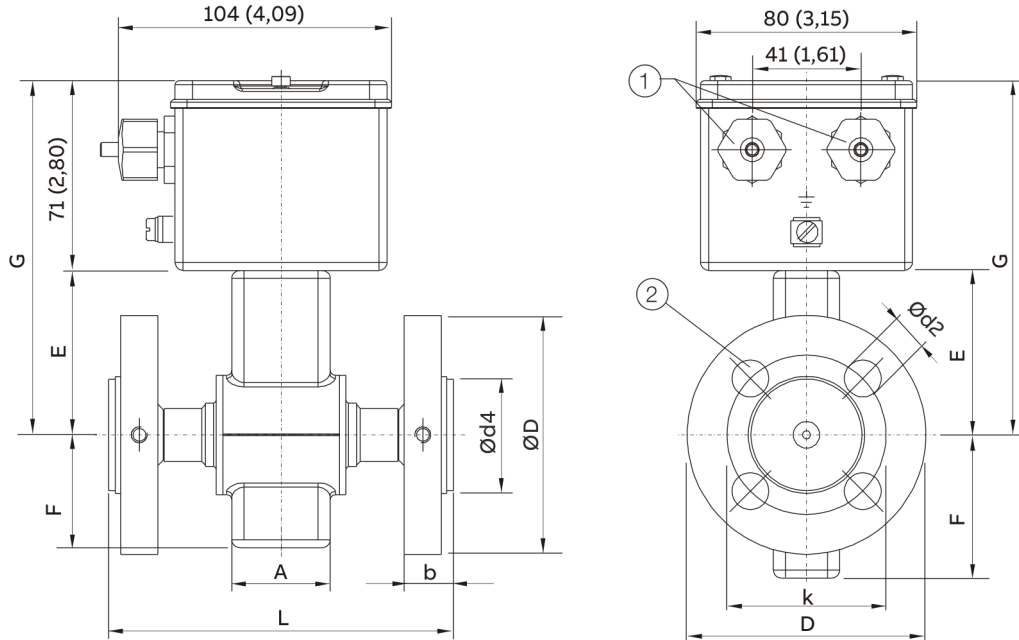

① Cable gland M20 x 1.5 or NPT

② Number of holes N

Figure 24: Dimensions in mm (in)

Flange dimensions acc. to DIN / EN, liner PFA												
DN	PN	mm										Weight kg approx.
		L ³⁾	A	D	k	d4	d2	b	E	F	G	
3 to 8 ³⁾	10 to 40	130	37	90	60	42	14	18	62	39	133	2.5
10, 15		200	37	90, 95	65	36	14	18	62	39	133	2.5
20		200	42	105	75	41	14	20	66	43	137	2.5
25		200	54	115	85	54	14	20	73	48	144	3
32		200	62	140	100	64	14	20	78	53	149	4
40		200	67	150	110	74	14	20	82	57	153	4.5

DN	PN	in										Weight lb approx.
		L ³⁾	A	D	k	d4	d2	b	E	F	G	
3 to 8 ³⁾	10 to 40	5.12	1.46	3.54	2.36	1.65	0.55	0.71	2.44	1.54	5.24	5.5
10, 15		7.87	1.46	3.54, 3.74	2.56	1.42	0.55	0.71	2.44	1.54	5.24	5.5
20		7.87	1.65	4.13	2.95	1.61	0.55	0.79	2.60	1.69	5.39	5.5
25		7.87	2.13	4.53	3.35	2.13	0.55	0.79	2.87	1.89	5.67	6.6
32		7.87	2.44	5.51	3.94	2.52	0.55	0.79	3.07	2.09	5.87	8.8
40		7.87	2.64	5.91	4.33	2.91	0.55	0.79	3.23	2.24	6.02	9.9

- 1) If a grounding plate is required, L + 3 mm (0.12"), material upon request. With 2 grounding plates (protection plates) L + 6 mm (0.24"), material upon request.
- 2) Connection dimensions according to EN1092-1
- 3) Connection flange DN 10 (3/8")
- 4) Connection flange 1/2"

... Model SE21_

Flange dimensions acc. to ASME B16.5, liner PFA

in.	PN	mm										Weight kg approx.
		L ¹⁾	A	D	k	d4	d2	b	E	F	G	
1/10 to 5/16 ⁴⁾	CL 150	130	37	88.9	60.3	42.0	15.9	18.0	62	39	133	2.5
3/8 ⁴⁾ , 1/2		200	37	88.9	60.3	34.8	15.9	12.6	62	39	133	2.5
3/4		200	42	98.4	69.8	42.9	15.9	14.2	66	43	137	2.5
1		200	54	108.0	79.2	50.8	15.9	15.8	73	48	144	3
1 1/4		200	62	117.5	88.9	63.5	15.9	17.4	78	53	149	3
1 1/2		200	67	127.0	98.6	73.0	15.9	19.0	82	57	153	3.5
1/10 to 5/16 ⁴⁾	CL 300	130	37	95.2	66.7	42.0	15.9	18.0	62	39	133	2.5
3/8 ⁴⁾ , 1/2		200	37	95.2	66.7	34.8	15.9	15.8	62	39	133	2.5
3/4		200	42	117.5	82.5	42.9	19.0	17.4	66	43	137	2.5
1		200	54	123.8	88.9	50.8	19.0	19.0	73	48	144	3
1 1/4		200	62	133.3	98.4	63.5	19.0	20.5	78	53	149	4
1 1/2		200	67	155.6	114.3	73.0	22.2	22.1	82	57	153	4.5

in.	PN	in										Weight lb approx.
		L ¹⁾	A	D	k	d4	d2	b	E	F	G	
1/10 to 5/16 ⁴⁾	CL 150	5.12	1.46	3.50	2.37	1.65	0.63	0.71	2.44	1.54	5.24	5.5
3/8 ⁴⁾ , 1/2		7.87	1.46	3.50	2.37	1.37	0.63	0.50	2.44	1.54	5.24	5.5
3/4		7.87	1.65	3.87	2.75	1.69	0.63	0.56	2.60	1.69	5.39	5.5
1		7.87	2.13	4.25	3.12	2.00	0.63	0.62	2.87	1.89	5.67	6.6
1 1/4		7.87	2.44	4.63	3.50	2.50	0.63	0.69	3.07	2.09	5.87	6.6
1 1/2		7.87	2.64	5.00	3.88	2.87	0.63	0.75	3.23	2.24	6.02	7.7
1/10 to 5/16 ⁴⁾	CL 300	5.12	1.46	3.75	2.63	1.65	0.63	0.71	2.44	1.54	5.24	5.5
3/8 ⁴⁾ , 1/2		7.87	1.46	3.75	2.63	1.37	0.63	0.62	2.44	1.54	5.24	5.5
3/4		7.87	1.65	4.63	3.25	1.69	0.75	0.69	2.60	1.69	5.39	5.5
1		7.87	2.13	4.87	3.50	2.00	0.75	0.75	2.87	1.89	5.67	6.6
1 1/4		7.87	2.44	5.25	3.87	2.50	0.75	0.81	3.07	2.09	5.87	8.8
1 1/2		7.87	2.64	6.13	4.50	2.87	0.87	0.87	3.23	2.24	6.02	9.9

1) If a grounding plate is required, L + 3 mm (0.12"), material upon request. With 2 grounding plates (protection plates) L + 6 mm (0.24"), material upon request.

2) Connection dimensions according to EN1092-1

3) Connection flange DN 10 (3/8")

4) Connection flange 1/2"

Stainless steel housing, flange according to DIN / EN 1092-1, DN 50 to DN 100; ASME B16.5, 2 to 4"

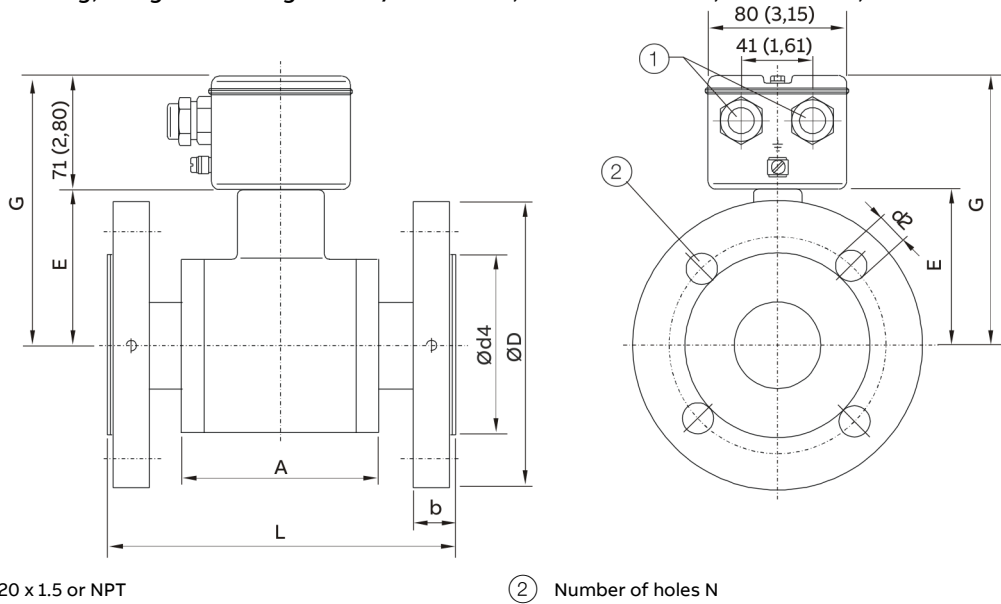

① Cable gland M20 x 1.5 or NPT

② Number of holes N

Figure 25: Dimensions in mm (in)

Flange dimensions acc. to DIN / EN, liner PFA

DN	PN	mm										Weight kg approx.
		L ¹⁾	A	D	k	d4	d2	N	b	E	G	
50	10 to 40	200	100	165	125	104	18	4	24	90	161	8
65 ²⁾	10 to 16	200	107	185	145	124	18	4	26	105	176	10
	25 to 40	200	107	185	145	124	18	8	26	105	176	10
80	10 to 40	200	107	200	160	139	18	8	28	114	185	12
100	10 to 16	250	159	220	180	161	18	8	24	128	199	18
	25 to 40	250	159	235	190	167	22	8	28	128	199	18

DN	PN	in										Weight lb approx.
		L ¹⁾	A	D	k	d4	d2	N	b	E	G	
50	10 to 40	7.87	3.94	6.50	4.92	4.09	0.71	0.16	0.94	3.54	6.34	17.6
65 ²⁾	10 to 16	7.87	4.21	7.28	5.71	4.88	0.71	0.16	1.02	4.13	6.93	22.0
	25 to 40	7.87	4.21	7.28	5.71	4.88	0.71	0.31	1.02	4.13	6.93	22.0
80	10 to 40	7.87	4.21	7.87	6.30	5.47	0.71	0.31	1.10	4.49	7.28	26.5
100	10 to 16	9.84	6.26	8.66	7.09	6.34	0.71	0.31	0.94	5.04	7.83	39.7
	25 to 40	9.84	6.26	9.25	7.48	6.57	0.87	0.31	1.10	5.04	7.83	39.7

1) If a grounding plate is required, L + 3 mm (0.12"), material upon request. With 2 grounding plates (protection plates) L + 6 mm (0.24"), material upon request.

2) For DN 65/PN 16 according to EN1092-1 please order PN 40.

... Model SE21_

Flange dimensions acc. to ASME B16.5, liner PFA

in.	PN	mm										Weight
		L ¹⁾	A	D	k	d4	d2	N	b	E	G	kg approx.
2	CL 150	200	100	152	121	99	19	4	23	90	161	8
2½		200	107	178	140	118	19	4	26	105	176	10
3		200	107	191	152	131	19	4	28	114	185	12
4		250	159	229	190	171	19	8	28	128	199	18
2	CL 300	200	100	165	127	102	19	8	26	90	161	8
2½		200	107	191	149	124	22	8	29	105	176	10
3		200	107	210	168	143	22	8	32	114	185	12
4		250	159	254	200	177	22	8	36	128	199	18
in.	PN	in										Weight
		L ¹⁾	A	D	k	d4	d2	N	b	E	G	lb approx.
2	CL 150	7.87	3.94	5.98	4.76	3.90	0.75	0.16	0.91	3.54	6.34	17.6
2½		7.87	4.21	7.01	5.51	4.65	0.75	0.16	1.02	4.13	6.93	22.0
3		7.87	4.21	7.52	5.98	5.16	0.75	0.16	1.10	4.49	7.28	26.5
4		9.84	6.26	9.02	7.48	6.73	0.75	0.31	1.10	5.04	7.83	39.7
2	CL 300	7.87	3.94	6.50	5.00	4.02	0.75	0.31	1.02	3.54	6.34	17.6
2½		7.87	4.21	7.52	5.87	4.88	0.87	0.31	1.14	4.13	6.93	22.0
3		7.87	4.21	8.27	6.61	5.63	0.87	0.31	1.26	4.49	7.28	26.5
4		9.84	6.26	10.00	7.87	6.97	0.87	0.31	1.42	5.04	7.83	39.7

1) If a grounding plate is required, L + 3 mm (0.12"), material upon request. With 2 grounding plates (protection plates) L + 6 mm (0.24"), material upon request.

Model SE21W

Stainless steel housing, wafer type DN 3 to DN 100 (1/10 to 4")

DN 3 to DN 40 (1/10 to 1 1/2")

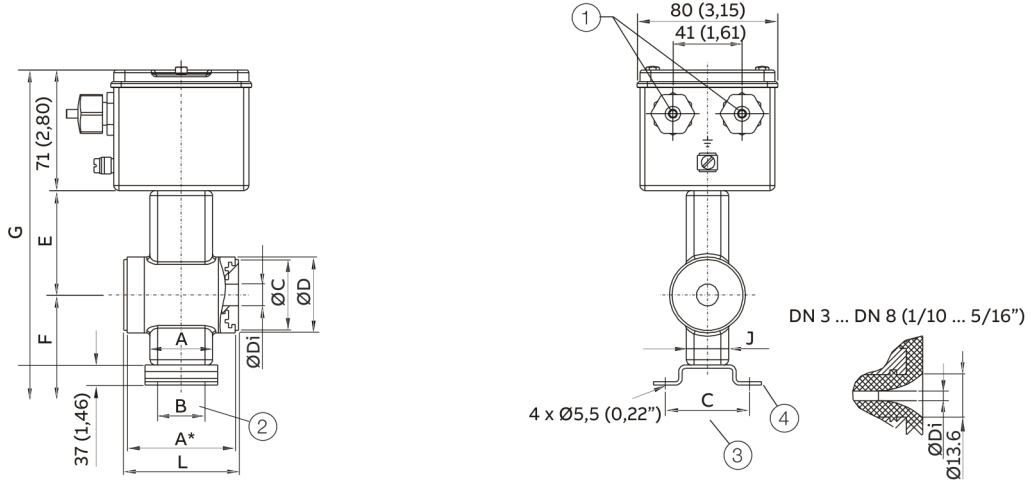

DN 50 to DN 100 (2 to 4")

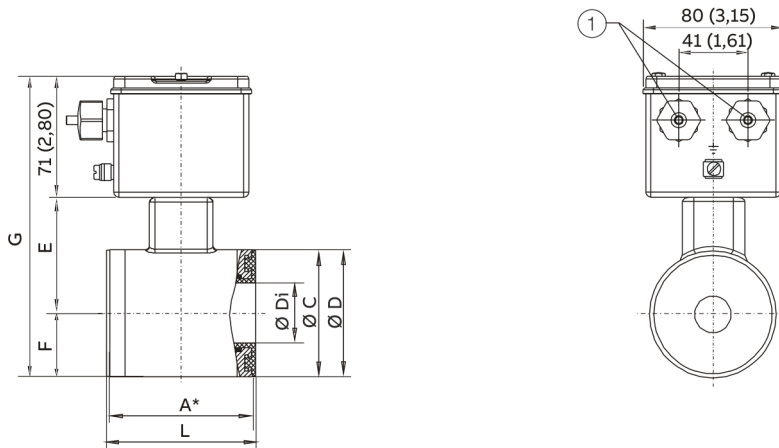

- ① Cable gland Pg 13.5 or NPT
- ② Hole pattern shaft holes

- ③ Hole pattern
- ④ Mounting bracket (optional)

Figure 26: Dimensions in mm (inch)

... Model SE21_

DN (inch)	PN	mm												Weight kg approx.		
		L ^{1) 2)}	L ^{1) 3)}	A*	A	B	C	ØC	ØDi	ØD	E	F	G		J	
3 (1/10)									3							
4 (5/32)									4							
6 (1/4)		68	68	64	37	28	50	42	6	45	62	39	172	28	1.5	
8 (5/16)									8							
10 (3/8)	10 to 40								10							
15 (1/2)	CL150								13					32		
20 (3/4)	CL300	78	78	74	42	28	50	50	18	54	66	43	205	32	2.0	
25 (1)	JIS	90	90	86	42	46	70	59	24	63	73	48	219	32	2.0	
32 (1 1/4)		98	98	94	42	46	70	69	30	73	78	53	229	32	2.5	
40 (1 1/2)		103	103	99	42	46	70	77	36	82	82	57	237	32	3.0	
50 (2)		117	117	112	-	60	110	95	47	100	90	50	213	-	4.0	
65 (2 1/2)	10 to 16	103	200	99	-	60	110	111	62	116	105	58	235	-	4.5	
80 (3)	CL150	103	200	99	-	60	110	128	74	133	114	67	252	-	6.5	
100 (4)	JIS	133	250	129	-	60	110	155	96	160	128	80	279	-	8.5	

DN (inch)	PN	in												Weight lb approx.		
		L ^{1) 2)}	L ^{1) 3)}	A*	A	B	C	ØC	ØDi	ØD	E	F	G		J	
3 (1/10)									0.12							
4 (5/32)									0.16							
6 (1/4)		2.68	68	2.52	1.46	1.10	1.97	1.65	0.24	1.77	2.44	1.54	6.77	1.10	3.3	
8 (5/16)									0.31							
10 (3/8)	10 to 40								0.39							
15 (1/2)	CL150								0.51					1.26		
20 (3/4)	CL300	3.07	78	2.91	1.65	1.10	1.97	1.97	0.71	2.13	2.60	1.69	8.07	1.26	4.4	
25 (1)	JIS	3.54	90	3.39	1.65	1.81	2.76	2.32	0.94	2.48	2.87	1.89	8.62	1.26	4.4	
32 (1 1/4)		3.86	98	3.70	1.65	1.81	2.76	2.72	1.18	2.87	3.07	2.09	9.02	1.26	5.5	
40 (1 1/2)		4.06	103	3.90	1.65	1.81	2.76	3.03	1.42	3.23	3.23	2.24	9.33	1.26	6.6	
50 (2)		4.61	117	4.41	-	2.36	4.33	3.74	1.85	3.94	3.54	1.97	8.39	-	8.8	
65 (2 1/2)	10 to 16	4.06	7.87	3.90	-	2.36	4.33	4.37	2.44	4.57	4.13	2.28	9.25	-	9.9	
80 (3)	CL150	4.06	7.87	3.90	-	2.36	4.33	5.04	2.91	5.24	4.49	2.64	9.92	-	14.3	
100 (4)	JIS	5.24	9.84	5.08	-	2.36	4.33	6.10	3.78	6.30	5.04	3.15	10.98	-	18.7	

1) Installation lengths with 2 grounding plates L + 3 mm (0.12")

2) Previous installation length. The installation length (old / new) is specified through the model number key. Old installation length for replacement purposes only.

3) New installation length.

Mounting bracket (optional)

With mounting bracket, combined height + 37 mm (1.46") DN 3 to DN 40 (1/10 to 1 1/2"), + 10.5 mm (0.41") DN 50 to DN 100 (2 to 4").

Model SE21_
Variable process connection

DN 3 to DN 40 (1/16" to 1 1/2")

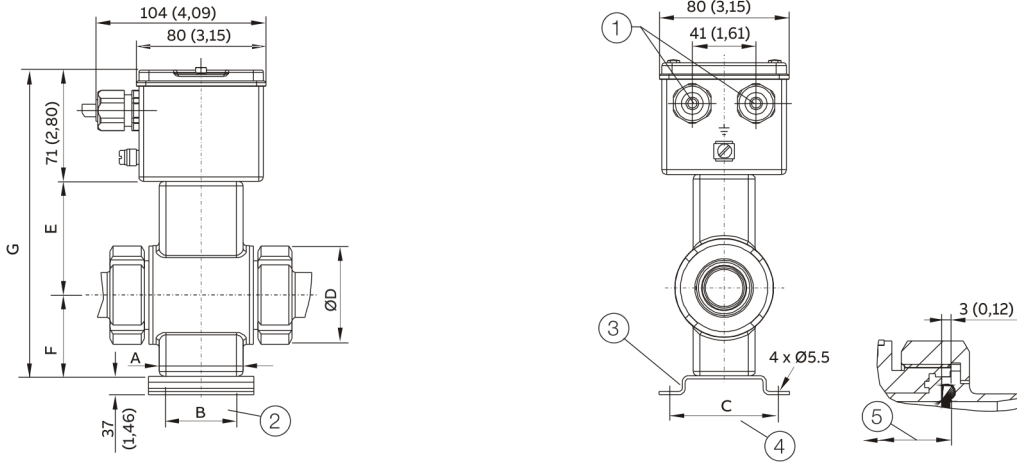

DN 50 to DN 100 (2 to 4")

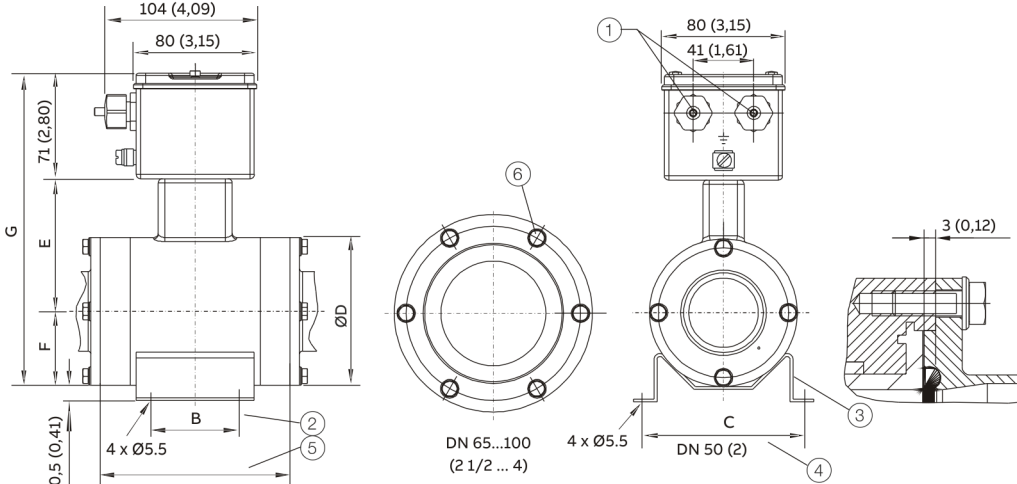

- ① Cable gland Pg 13.5 or NPT
- ② Hole pattern shaft holes
- ③ Mounting bracket (optional)

- ④ Hole pattern
- ⑤ Lpipe
- ⑥ Number of holes N

Figure 27: Dimensions in mm (inch)

... Model SE21_

DN (inch)	mm										Weight kg approx. ¹⁾
	A	ØD	B	C	E	F	G	Lpipe ²⁾	Lpipe ³⁾	N	
3 to 10 (¹ / ₁₀ to ³ / ₈)	37	44	28	50	62	39	172	85	85	–	1.5
15 (¹ / ₂)	37	44	28	50	62	39	172	85	85	–	1.5
20 (³ / ₄)	42	63	28	50	66	43	180	90	90	–	2.0
25 (1)	42	63	46	70	73	48	192	105	105	–	2.0
32 (1 ¹ / ₄)	42	78	46	70	78	53	202	120	120	–	2.5
40 (1 ¹ / ₂)	42	78	46	70	82	57	210	125	125	–	3.0
50 (2)	–	100	60	110	90	50	211	128	128	8	4.0
65 (2 ¹ / ₂)	–	116	60	110	105	58	234	114	200	10	4.5
80 (3)	–	133	60	110	114	67	252	114	200	6	6.5
100 (4)	–	160	60	110	128	80	279	114	250	6	9.0

DN (inch)	in										Weight lb approx. ¹⁾
	A	ØD	B	C	E	F	G	Lpipe ²⁾	Lpipe ³⁾	N	
3 to 10 (¹ / ₁₀ to ³ / ₈)	1.46	1.73	1.10	1.97	2.44	1.54	6.77	3.35	3.35	–	3.3
15 (¹ / ₂)	1.46	1.73	1.10	1.97	2.44	1.54	6.77	3.35	3.35	–	3.3
20 (³ / ₄)	1.65	2.48	1.10	1.97	2.60	1.69	7.09	3.54	3.54	–	4.4
25 (1)	1.65	2.48	1.81	2.76	2.87	1.89	7.56	4.13	4.13	–	4.4
32 (1 ¹ / ₄)	1.65	3.07	1.81	2.76	3.07	2.09	7.95	4.72	4.72	–	5.5
40 (1 ¹ / ₂)	1.65	3.07	1.81	2.76	3.23	2.24	8.27	4.92	4.92	–	6.6
50 (2)	–	3.94	2.36	4.33	3.54	1.97	8.31	5.04	5.04	0.31	8.8
65 (2 ¹ / ₂)	–	4.57	2.36	4.33	4.13	2.28	9.21	4.49	7.87	0.39	9.9
80 (3)	–	5.24	2.36	4.33	4.49	2.64	9.92	4.49	7.87	0.24	14.3
100 (4)	–	6.30	2.36	4.33	5.04	3.15	10.98	4.49	9.84	0.24	19.8

1) For process connection weights, see **Adapter for variable process connections DN 3 to 100 (1/8" to 4")** on page 39

2) Previous installation length. The installation length (old / new) is specified through the model number key. Old installation length for replacement purposes only.

3) New installation length.

Mounting bracket (optional)

With mounting bracket, combined height +37 mm (1.46") DN 3 to DN 40 (¹/₁₀ to 1¹/₂"),
+10.5 mm (0.41") DN 50 to DN 100 (2 to 4").

Adapter for variable process connections DN 3 to 100 (1/8" to 4")

All specified dimensions and weights are in mm (in) or kg (lb).

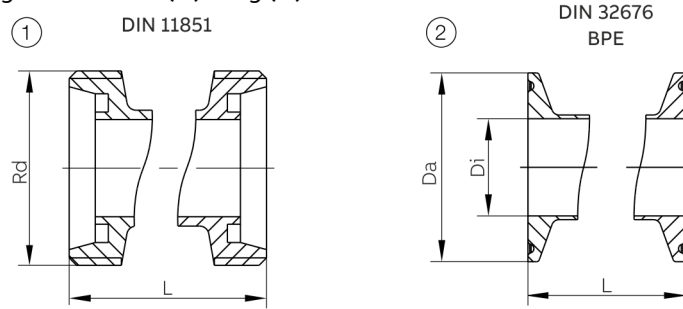

① Pipe fitting in accordance with DIN 11851

② Tri-clamp

Figure 28: Adapter for variable process connections DN 3 to 100

Threaded pipe connection in acc. with DIN 11851

Nominal diameter	Pressure rating	L (old*)	L (new**)	Thread	Ø Di	Weight
DN 3 to DN 10 (1/8" bis 3/8")	See the chapter titled Material loads for process connections on page 13	169 (6.65)		—	28 x 1/8"	10 (0.39)
DN 15 (1/2")		180 (7.09)		—	34 x 1/8"	16 (0.63)
DN 20 (3/4")		207 (8.15)		—	44 x 1/6"	20 (0.79)
DN 25 (1")		230 (9.06)		—	52 x 1/6"	26 (1.02)
DN 32 (1 1/4")		237 (9.33)		—	65 x 1/6"	38 (1.50)
DN 40 (1 1/2")		243 (9.57)		—	78 x 1/6"	50 (1.97)
DN 50 (2")		245 (9.65)	330.5 (13.01)		96 x 1/6"	66 (2.60)
DN 65 (2 1/2")		259 (10.20)	344.5 (13.56)		110 x 1/4"	81 (3.19)
DN 80 (3")		307 (12.09)	412.5 (16.24)		130 x 1/4"	100 (3.94)

* Old installation length for replacement purposes only. Please observe ordering information.

** New installation length.

... Model SE21_

Tri-clamp											
Nominal diameter	Pressure rating	In accordance with DIN 32676					In accordance with ASME BPE				
		L	Ø Da	Ø Di	Series	Weight	Process dimensions	L	Ø Da	Ø Di	Weight
DN 3 to DN 10 ($\frac{1}{8}$ bis $\frac{3}{8}$ "	See the chapter titled Material loads for process connections on page 13	163 (6.42)	34 (1.34)	10 (0.39)	3	0.5 (1.1)	1/2"	143 (5.63)	25 (0.98)	9.4 (0.37)	0.5 (1.1)
DN 15 ($\frac{1}{2}$ "				16 (0.63)			3/4"			15.7 (0.62)	
DN 20 ($\frac{3}{4}$ "		168 (6.61)		20 (0.79)	3	0.7 (1.5)	1"		50.4 (1.98)	22.1 (0.87)	0.7 (1.5)
DN 25 (1"		192 (7.56)	50.5 (1.99)	26 (1.02)	3	0.8 (1.8)	1 1/2"	277 (34.8)		22.1 (0.87)	1.2 (2.7)
DN 32 (1 1/4"		209 (8.23)		32 (1.26)	3	1.5 (3.3)	-	-	-	-	-
DN 40 (1 1/2"		214 (8.43)		38 (1.50)	3	1.4 (3.1)	1 1/2"	277 (34.8)	50.4 (1.98)	34.8 (1.37)	1.8 (4.0)
DN 50 (2"		216 (8.50)	64 (2.52)	50 (1.97)	3	1.2 (2.7)	2"		63.9 (2.52)	47.5 (1.87)	
DN 65 (2 1/2"		221 (8.70)*	91 (3.58)	66 (2.60)	1	1.6 (3.5)	2 1/2"		77.4 (3.05)	60.2 (2.37)	2.0 (4.4)
		306.5 (12.07) ²⁾									
DN 80 (3"		225 (8.86)*	106 (4.17)	81 (3.19)	1	2.4 (5.3)	3"	337 (13.27)	90.9 (3.58)	72.9 (2.87)	3.6 (8.0)
	310.5 (12.22)**										
DN 100 (4"	255 (8.86)*	119 (4.69)	100 (3.94)	1	3.1 (6.8)	4"		118.8 (4.68)	97.4 (3.83)	4.1 (9.1)	
	360.5 (14.19)**										

* Old installation length for replacement purposes only. Please observe ordering information.

** New installation length.

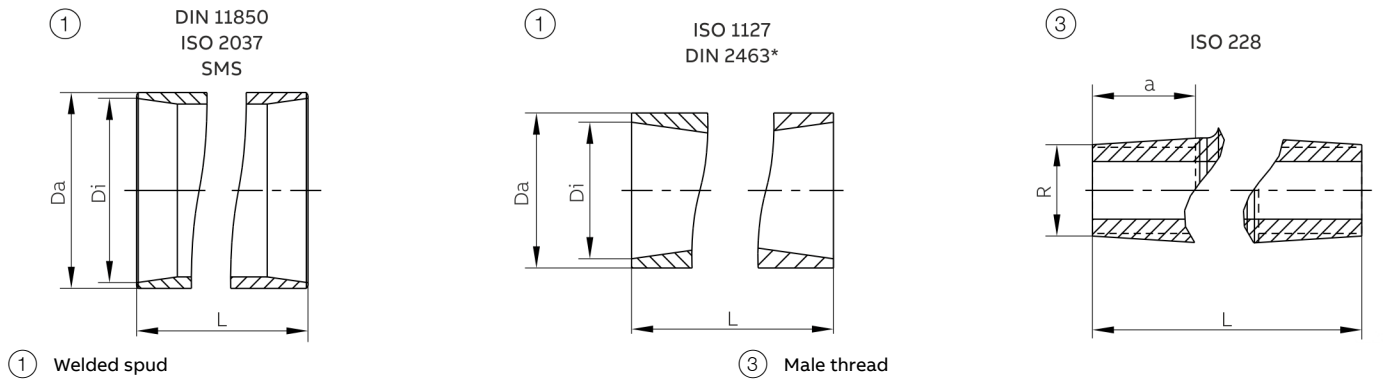

Figure 29: Adapter for variable process connections DN 3 to 100

Welded spuds

Nominal diameter	Pressure rating	L	In accordance with DIN 11850			In accordance with ISO 1127			In accordance with SMS		Weight
			Ø Da	Ø Di	Series	Ø Da	Ø Di	Series	Ø Da	Ø Di	
DN 3 to DN 10 ($\frac{1}{8}$ bis $\frac{3}{8}$ "	See the chapter titled Material loads for process connections on page 13	127 (5.0)	13 (0.51)	10 (0.39)	2	13.5 (0.53)	10.3 (0.41)	1	—	—	0.4 (0.9)
DN 15 ($\frac{1}{2}$ "		19 (0.75)	16 (0.63)	—	—	21.3 (0.84)	18.1 (0.71)	—	—	0.4 (0.9)	
DN 20 ($\frac{3}{4}$ "		132 (5.2)	23 (0.91)	20 (0.79)	—	26.9 (1.06)	23.7 (0.93)	—	—	0.7 (1.5)	
DN 25 (1"		149 (5.87)	29 (1.14)	26 (1.02)	—	26.9 (1.06)	23.7 (0.93)	25 (0.98)	22.6 (0.89)	0.7 (1.5)	
DN 32 (1 $\frac{1}{4}$ "		166 (6.54)	34 (1.34)	32 (1.26)	1	33.7 (1.33)	30.5 (1.20)	—	—	1.0 (2.2)	
DN 40 (1 $\frac{1}{2}$ "		171 (6.73)	41 (1.61)	38 (1.50)	2	42.2 (1.66)	39 (1.54)	1	38 (1.50)	35.6 (1.40)	1.0 (2.2)
DN 50 (2"		173 (6.81)	54 (2.13)	50 (1.97)	3	51 (2.01)	47.8 (1.88)	2	51 (2.01)	48.6 (1.91)	1.0 (2.2)
DN 65 (2 $\frac{1}{2}$ "		165 (6.50)*	70 (2.76)	66 (2.60)	2	70 (2.76)	66 (2.60)	2	63.5 (2.50)	60.3 (2.37)	1.4 (3.1)
		250.5 (9.86)**									
DN 80 (3"		169 (6.65)*	85 (3.35)	81 (3.19)	—	76.1 (3.00)	72.9 (2.87)	1	76.1 (3.00)	72.9 (2.87)	2.0 (4.4)
	254.5 (10.02)**										
DN 100 (4"	199 (7.83)*	104 (4.09)	100 (3.94)	—	101.6 (4.00)	97.6 (3.84)	2	104 (4.09)	100 (3.94)	2.6 (5.7)	
	304.5 (11.99)**										

* Old installation length for replacement purposes only. Please observe ordering information.

** New installation length.

... Model SE21_

Welded spuds								
Nominal diameter	Pressure rating	L	In accordance with DIN EN ISO 2037		In accordance with DIN 2463		Weight	
			Ø Da	Ø Di	Ø Da	Ø Di		
DN 3 to DN 10 ($\frac{1}{8}$ bis $\frac{3}{8}$ "	See chapter		127 (5.0)	12 (0.47)	10 (0.39)	13.5 (0.53)	10.3 (0.41)	0.4 (0.9)
	Material loads for process connections on							
DN 15 ($\frac{1}{2}$ "				17.2 (0.68)	15.2 (0.60)	21.3 (0.84)	18.1 (0.71)	0.4 (0.9)
DN 20 ($\frac{3}{4}$ "			132 (5.2)	21.3 (0.84)	19.3 (0.76)	26.9 (1.06)	23.7 (0.93)	0.7 (1.5)
DN 25 (1"	page 13		149 (5.87)	25 (0.98)	22.6 (0.89)	28 (1.10)	25 (0.98)	0.7 (1.5)
DN 32 (1 $\frac{1}{4}$ "			166 (6.54)	33.7 (1.33)	31.3 (1.23)	35 (1.38)	32 (1.26)	1.0 (2.2)
DN 40 (1 $\frac{1}{2}$ "			171 (6.73)	38 (1.5)	35.6 (1.40)	40 (1.57)	36.8 (1.45)	1.0 (2.2)
DN 50 (2"			173 (6.81)	51 (2.01)	48.6 (1.91)	52 (2.05)	49 (1.93)	1.0 (2.2)
DN 65 (2 $\frac{1}{2}$ "			165 (6.50)*	63.5 (2.50)	60.3 (2.37)	70 (2.76)	66 (2.60)	1.4 (3.1)
			250.5 (9.86)**					
DN 80 (3"			169 (6.65)*	76.1 (3.00)	72.9 (2.87)	85 (3.35)	81 (3.19)	2.0 (4.4)
			254.5 (10.02)**					
DN 100 (4"			199 (7.83)*	101.6 (4.00)	97.6 (3.84)	104 (4.09)	100 (3.94)	3.0 (6.6)
			304.5 (11.99)**					

* Old installation length for replacement purposes only. Please observe ordering information.

** New installation length.

External thread in acc. with ISO 228 / DIN 2999

Nominal diameter	Pressure rating	L	R	a	Weight	
DN 3 to 10 ($\frac{1}{8}$ to $\frac{3}{8}$ "	See the chapter titled Material loads for process connections on		139 (5.47)	$\frac{3}{8}$ "	18 (0.71)	0.4 (0.9)
DN 15 ($\frac{1}{2}$ "			139 (5.47)	$\frac{1}{2}$ "	18 (0.71)	0.4 (0.9)
DN 20 ($\frac{3}{4}$ "			164 (6.46)	$\frac{3}{4}$ "	25 (0.98)	0.8 (1.8)
DN 25 (1"	page 13		179 (7.05)	1"	25 (0.98)	0.8 (1.8)

Weld stubs suitable for OD tubing

Nominal diameter	Pressure rating	Welded spud size	Di	Da	L	Weight	
10 ($\frac{3}{8}$ "	See the chapter titled Material loads for process connections on		$\frac{1}{2}$ "	9.40 (0.37)	12.70 (0.70)	127 (5.00)	0.4 (0.9)
15 ($\frac{1}{2}$ "			$\frac{3}{4}$ "	15.75 (0.62)	19.05 (0.75)	127 (5.00)	0.4 (0.9)
20 (1"			1"	22.10 (0.87)	25.40 (1.00)	132 (5.20)	0.7 (1.5)
25 (1"			1"	22.10 (0.87)	25.40 (1.00)	149 (5.87)	1.0 (2.2)
40 (1 $\frac{1}{2}$ "	page 13		1 $\frac{1}{2}$ "	34.80 (1.37)	38.10 (1.50)	171 (6.73)	
50 (2"			2"	47.50 (1.87)	50.80 (2.00)	173 (6.81)	

Ordering information

FSM4000-SE21, remote, welded flange, 2000 series stainless steel housing

Main order number															
Electromagnetic Flowmeter FSM4000	SE21F-	X	XXX	X	X	X	X	X	X	X	X	X	X	XXX	XXX
Process Connection															
Welded flange DIN 2501 / ASME	F														
Liner Material / Meter Size															
PFA / DN 3 (1/10 in)			P03												
PFA / DN 4 (5/32 in)			P04												
PFA / DN 6 (1/4 in)			P06												
PFA / DN 8 (5/16 in)			P08												
PFA / DN 10 (3/8 in)			P10												
PFA / DN 15 (1/2 in)			P15												
PFA / DN 20 (3/4 in)			P20												
PFA / DN 25 (1 in)			P25												
PFA / DN 32 (1-1/4 in)			P32												
PFA / DN 40 (1-1/2 in)			P40												
PFA / DN 50 (2 in)			P50												
PFA / DN 65 (2-1/2 in)			P65												
PFA / DN 80 (3 in)			P80												
PFA / DN 100 (4 in)			P1H												
Measuring Electrodes Material / Grounding Electrodes															
Hastelloy C-4 (2.4610) / Without															H
Hastelloy B-3 (2.4600) / Without															B
AISI 316Ti SST (1.4571) / Without															S
Titanium / Without															M
Tantalum / Without															T
AISI 904L SST (1.4539) / Without															F ¹⁾
Platinum-Iridium / Without															P
Hastelloy C-4 (2.4610) / With															O
Hastelloy B-3 (2.4600) / With															N
AISI 316Ti SST (1.4571) / With															E
Titanium / With															I
Tantalum / With															Q
AISI 904L SST (1.4539) / With															R ¹⁾
Platinum-Iridium / With															G
Pressure Rating															
PN 16															D ²⁾
PN 40															F
ASME CL 150															P
ASME CL 300															Q
Material of Process Connection															
AISI 316Ti SST (1.4571)															3
Accessories															
Without															A
Protection rings AISI 316Ti SST (1.4571)															B ³⁾
Grounding ring AISI 316Ti SST (1.4571)															C ³⁾

- 1) For food and beverage applications
- 2) DN 65 (2-1/2 in) / PN 16 with connection dimensions acc. EN 1092-1: Please order PN 40
- 3) Protection rings mounted on both sides and ground rings mounted on one side to flange

Continued on next page

... Model SE21_

Main order number																		
Electromagnetic Flowmeter FSM4000	SE21F-	X	XXX	X	X	X	X	X	X	X	X	X	X	X	X	X	XXX	XXX
Temperature Range																		
Standard design (<= 130 °C [266 °F])																		
S																		
Certificates																		
PED Standard																		
A																		
Material certificate 3.1 acc. EN 10204 with pressure test acc. AD2000																		
D ⁴⁾																		
Pressure test acc. AD2000																		
G																		
Inspection certificate 3.1 acc. EN 10204																		
F																		
Calibration Certificates																		
Standard																		
A																		
Fingerprint saved at factory																		
F ⁵⁾																		
Type of Protection / Cable Entry																		
IP 67 / Thread for screw-type conduit fitting M20 x 1.5																		
2																		
IP 67 / Thread for screw-type conduit fitting NPT 1/2 in																		
4																		
IP 68 / Thread for screw-type conduit fitting M20 x 1.5																		
7 ⁶⁾																		
IP 68 / Cable connected and connection box potted																		
8																		
Design																		
Without pre-amplifier																		
1 ⁷⁾																		
With pre-amplifier type A																		
2 ⁸⁾																		
With pre-amplifier type B																		
4 ⁹⁾																		
Name Plate Language / Type																		
German / Adhesive foil																		
G																		
English / Adhesive foil																		
E																		
French / Adhesive foil																		
F																		
German / Stainless steel																		
J																		
English / Stainless steel																		
K																		
French / Stainless steel																		
L																		
Design Level																		
(Specified by ABB)																		
x																		
Electrode Design																		
Standard																		
1																		
Conical head, AISI 904L SST (1.4539)																		
2 ¹⁰⁾																		

4) Material certificate for meter tube and flanges

5) DN 8 (5/16 in)

6) Sealing compound (optional): D141B038U01

7) From DN 10 (3/8 in) >= 20 µS/cm

8) Standard up to DN 8 (5/16 in) >= 20 µS/cm, > DN 8 (5/16 in) >= 5 µS/cm and lay length max. 200 m (660 ft)

9) Option: Up to DN 8 (5/16 in) >= 5 µS/cm, > DN 8 (5/16 in) >= 0.5 µS/cm and lay length max. 200 m (660 ft)

10) For application e.g. with high fat contents

Continued on next page

Main order number	
Electromagnetic Flowmeter FSM4000	SE21F- X XXX X X X X X X X X X X X X X XXX XXX
Signal Cable Length	
Without cable	000
5 m (16 ft)	005
10 m (33 ft)	010
20 m (66 ft)	020
30 m (100 ft)	030
40 m (131 ft)	040
50 m (164 ft)	050
60 m (197 ft)	060
70 m (230 ft)	070
80 m (262 ft)	080
90 m (295 ft)	090
100 m (328 ft)	100
125 m (410 ft)	125
150 m (490 ft)	150
175 m (570 ft)	175
200 m (660 ft)	200
Excitation Cable Length	
Without cable	000
5 m (16 ft)	005
10 m (33 ft)	010
20 m (66 ft)	020
30 m (100 ft)	030
40 m (131 ft)	040
50 m (164 ft)	050
60 m (197 ft)	060
70 m (230 ft)	070
80 m (262 ft)	080
90 m (295 ft)	090
100 m (328 ft)	100
125 m (410 ft)	125
150 m (490 ft)	150
175 m (570 ft)	175
200 m (660 ft)	200

Continued on next page

... Model SE21_

Additional order number

Additional order number			
Electromagnetic Flowmeter FSM4000 SE21F-	XX	XX	XX
Calibration			
2 points (standard)	VK		
3 point standard calibration	VC		
Witnessed calibration, 5 calibration points	VE ¹¹⁾		
5 point calibration acc. ISO 17025	VD ¹¹⁾		
Language of Documentation			
German		M1	
English		M5	
Russian		MB	
Language package Western Europe / Scandinavia (Languages: FR, ES, DA, IT, NL, PT, SV, FI)		MW	
Language package Eastern Europe (Languages: EL, CS, ET, HU, HR, LT, LV, PL, SK, SL, RO, BG)		ME	
Others		MZ	
Lay Length			
Old length for DN 1 - 100			JE
New length for DN 65, DN 80, DN 100			JF

11) Only available with FSM4000-S4 External Converter

FSM4000-SE21, Wafer Type, Variable Process Connections, Liner Material PFA

Main order number																			
Electromagnetic Flowmeter FSM4000	SE21- X XXX X	X	X	X	X	X	X	X	X	X	X	X	X	X	X	X	X	XXX	XXX
Process Connection																			
Wafer type	W																		
Weld stubs DIN 11850	R																		
Weld stubs DIN 2463	Q																		
Weld stubs ISO 1127	J																		
Weld stubs SMS	X																		
Without adapter	V ¹⁾																		
Weld stubs ISO 2037	P																		
Pipe connection acc. DIN 11851	S																		
Tri-Clamp DIN 32676	T																		
Tri-Clamp ASME BPE	K																		
Male thread acc. ISO 228 / DIN 2999 (conical)	E																		
Liner Material / Meter Size																			
PFA / DN 3 (1/10 in)	P03																		
PFA / DN 4 (5/32 in)	P04																		
PFA / DN 6 (1/4 in)	P06																		
PFA / DN 8 (5/16 in)	P08																		
PFA / DN 10 (3/8 in)	P10																		
PFA / DN 15 (1/2 in)	P15																		
PFA / DN 20 (3/4 in)	P20																		
PFA / DN 25 (1 in)	P25																		
PFA / DN 32 (1-1/4 in)	P32																		
PFA / DN 40 (1-1/2 in)	P40																		
PFA / DN 50 (2 in)	P50																		
PFA / DN 65 (2-1/2 in)	P65																		
PFA / DN 80 (3 in)	P80																		
PFA / DN 100 (4 in)	P1H																		
Measuring Electrodes Material / Grounding Electrodes																			
Hastelloy C-4 (2.4610) / Without	H																		
Hastelloy B-3 (2.4600) / Without	B																		
AISI 316Ti SST (1.4571) / Without	S																		
Titanium / Without	M																		
Tantalum / Without	T																		
AISI 904L SST (1.4539) / Without	F ²⁾																		
Platinum-Iridium / Without	P																		
Hastelloy C-4 (2.4610) / With	O																		
Hastelloy B-3 (2.4600) / With	N																		
AISI 316Ti SST (1.4571) / With	E																		
Titanium / With	I																		
Tantalum / With	Q																		
AISI 904L SST (1.4539) / With	R ²⁾																		
Platinum-Iridium / With	G																		

1) For food and beverage applications

2) DN 65 (2-1/2 in) / PN 16 with connection dimensions according to EN 1092-1: Please order PN 40

Continued on next page

Main order number																									
Electromagnetic Flowmeter FSM4000										SE21-	X	XXX	X	X	X	X	X	X	X	X	X	X	X	XXX	XXX
Name Plate Language / Type																									
German / Adhesive foil																	G								
English / Adhesive foil																	E								
French / Adhesive foil																	F								
German / Stainless steel																	J								
English / Stainless steel																	K								
French / Stainless steel																	L								
Design Level																									
(Specified by ABB)																	x								
Electrode Design																									
Standard																	1								
Conical head, AISI 904L SST (1.4539)																	2 ¹⁴⁾								
Gasket Material																									
Without																			A						
EPDM (with FDA certificate)																			E						
Silicone (with FDA certificate)																			S						
PTFE																			T ⁵⁾						
Signal Cable Length																									
Without cable																			000						
5 m (16 ft)																			005						
10 m (33 ft)																			010						
20 m (66 ft)																			020						
30 m (100 ft)																			030						
40 m (131 ft)																			040						
50 m (164 ft)																			050						
60 m (197 ft)																			060						
70 m (230 ft)																			070						
80 m (262 ft)																			080						
90 m (295 ft)																			090						
100 m (328 ft)																			100						
125 m (410 ft)																			125						
150 m (490 ft)																			150						
175 m (570 ft)																			175						
200 m (660 ft)																			200						

14) For application e.g. with high fat contents

5) DN 1 ... DN 2 (1/25 ... 1/12 in)

Continued on next page

... Model SE21_

Main order number

Electromagnetic Flowmeter FSM4000	SE21-	X	XXX	X	X	X	X	X	X	X	X	X	X	X	X	X	X	XXX	XXX
-----------------------------------	-------	---	-----	---	---	---	---	---	---	---	---	---	---	---	---	---	---	-----	-----

Excitation Cable Length

Without cable	000
5 m (16 ft)	005
10 m (33 ft)	010
20 m (66 ft)	020
30 m (100 ft)	030
40 m (131 ft)	040
50 m (164 ft)	050
60 m (197 ft)	060
70 m (230 ft)	070
80 m (262 ft)	080
90 m (295 ft)	090
100 m (328 ft)	100
125 m (410 ft)	125
150 m (490 ft)	150
175 m (570 ft)	175
200 m (660 ft)	200

Additional order number

Additional order number

Electromagnetic Flowmeter FSM4000 SE21-	XX	XX	XX
---	----	----	----

Calibration

2 points (standard)	VK
3 point standard calibration	VC
Witnessed calibration, 5 calibration points	VE ¹⁶⁾
point calibration acc. ISO 17025	VD ¹⁶⁾

Language of Documentation

German	M1
English	M5
Russian	MB
Language package Western Europe / Scandinavia (Languages: FR, ES, DA, IT, NL, PT, SV, FI)	MW
Language package Eastern Europe (Languages: EL, CS, ET, HU, HR, LT, LV, PL, SK, SL, RO, BG)	ME
Others	MZ

Lay Length

Old length for DN 1 - 100	JE
New length for DN 65, DN 80, DN 100	JF

16) Only available with FSM4000-S4 External Converter

Mounting accessories

Wafer type accessories

Depending on the nominal diameter and nominal pressure, the following accessories are available: bolts, nuts, spring washers. Gaskets are not included in the accessories.

Designation	Nominal diameter	Nominal pressure rating	Ordering number
FX / FSM wafer type accessories, stainless steel	DN 3 to DN 10 (1/10 to 3/8 in.)	PN 10 to PN 40	D614L265U03
		ASME CL 150	D614L265U03
		ASME CL 300	D614L265U04
DN 15 (1/2 in.)	DN 15 (1/2 in.)	PN 10 to PN 40	D614L265U03
		ASME CL 150	D614L266U05
		ASME CL 300	D614L266U06
DN 20 (3/4 in.)	DN 20 (3/4 in.)	PN 10 to PN 40	D614L267U04
		ASME CL 150	D614L267U05
		ASME CL 300	D614L267U06
DN 25 (1 in.)	DN 25 (1 in.)	PN 10 to PN 40	D614L268U04
		ASME CL 150	D614L268U05
		ASME CL 300	D614L268U06
DN 32 (1-1/4 in.)	DN 32 (1-1/4 in.)	PN 10 to PN 40	D614L269U04
		ASME CL 150	D614L269U05
		ASME CL 300	D614L269U06
DN 40 (1-1/2 in.)	DN 40 (1-1/2 in.)	PN 10 to PN 40	D614L270U04
		ASME CL 150	D614L270U05
		ASME CL 300	D614L270U06
DN 50 (2 in.)	DN 50 (2 in.)	PN 10 to PN 40	D614L296U04
		ASME CL 150	D614L296U05
		ASME CL 300	D614L296U06
DN 65 (2-1/2 in.)	DN 65 (2-1/2 in.)	PN 10 to PN 16	D614L297U08
		PN 25 to PN 40	D614L297U09
		ASME CL 150	D614L297U10
		ASME CL 300	D614L297U11
DN 80 (3 in.)	DN 80 (3 in.)	PN 10 to PN 40	D614L298U08
		ASME CL 150	D614L298U09
		ASME CL 300	D614L298U10
DN 100 (4 in.)	DN 100 (4 in.)	PN 10 to PN 16	D614L299U07
		PN 25 to PN 40	D614L299U08
		ASME CL 150	D614L299U09

... Mounting accessories

Weld-in adapter

For sensors with welded spud connection, welding adapters are available.

Material	Nominal diameter	Ordering number
Stainless steel 1.4301 (AISI 304)	DN 3 to DN 10 (1/10 to 3/8 in.)	D413C470U01
	DN 15 (1/2 in.)	D413C471U01
	DN 20 (3/4 in.)	D413C472U01
	DN 25 (1 in.)	D413C473U01
	DN 32 (1-1/4 in.)	D413C474U01
	DN 40 (1-1/2 in.)	D413C475U01
	DN 50 (2 in.)	D413C488U03
	DN 65 (2-1/2 in.)	D413C461U09
	DN 80 (3 in.)	D413C496U03
	DN 100 (4 in.)	D413C498U03

The adapter is a tool for sensors with the 'welded spud' process connection. It enables these weld stubs to be welded into the pipeline in a coplanar manner.

Transmitter

Specifications



Figure 30: Transmitter FSM4000-S4

Meas. range	Any flow range whose 100% value corresponds to a flow velocity between 0.5 m/s and 10 m/s can be selected.	
Minimum conductivity	$\geq 20 \mu\text{S/cm}$ standard	DN 10 to DN 1000 ($\frac{3}{8}$ to 40")
	$\geq 20 \mu\text{S/cm}$ with preamplifier	DN 3 to DN 8 ($\frac{1}{25}$ to $\frac{5}{16}$ ")
	$\geq 5 \mu\text{S/cm}$ with preamplifier	DN 3 to 1000 ($\frac{1}{25}$ to 40")
	$\geq 0.5 \mu\text{S/cm}$ with preamplifier	DN 10 to DN 1000 ($\frac{3}{8}$ to 40")
Repeatability (measurement period = 100 s)	DN 3 to 1000 (1/10 to 40"): $\leq \pm (0.1 \% \text{ of measured value} + 0.01 \% \text{ of } Q_{\text{max DN}})$	
Response time	1 τ = 70 ms (0 to 66 %) Fast operating mode 1 τ = 200 ms (0 to 66 %) Standard/piston pump operating mode	
Power supply	U = 100 to 230 V, 50/60 Hz U _{rat} = 85 to 253 V, 50/60 Hz 50/60 Hz $\pm 6\%$ 20.4 to 26.4 V AC, 20.4 to 31.2 V DC, ripple $\leq 5\%$	
Power consumption	S ≤ 45 VA (sensor including transmitter)	
Ambient temperature	-20 to 60 °C (-4 to 140 °F)	
Storage temperature	-20 to 80 °C (-4 to 176 °F)	

Relative humidity

Acc. to IEC 60068-2-30 classification of environmental conditions, natural factors, temperature and air humidity.

No effect under the following operating conditions: temperature ranging from 25 to 55 °C (77 to 131 °F) and a relative air humidity of 94 to 97 %.

Vibration

In accordance with IEC 60068-2-6 (03/95), grouping of devices according to table C2 for general industry applications. No additional effect on the following levels of vibration. Frequency range 10 to 55 Hz; amplitude max. 0.15 mm.

IP rating in accordance with EN 60529

IP 67 for field-mount housing and NEMA 4X

Design

Field-mount housing made of cast aluminum per DIN 1725, painted.

Paint coat thickness 80 μm . Lower section (RAL 7012), upper section (RAL 9002). For dimensions, see **Dimensions** on page 66. Weight, approx. 3.3 kg.

Electrical connections

Cable entry M20 \times 1.5, NPT, PF with adapter (upon request), screw terminals

Damping (1 τ)

Can be configured from 0.07 to 20 s

Low flow cutoff

Can be set to 0 to 10 % of the final value

Signal cable

Max. cable length between flowmeter sensor and transmitter is:

- 50 m for the standard design and versions with automatic zero return, from DN 10 (3/8") and from 20 $\mu\text{S/cm}$.
- 200 m for designs with preamplifier.

A 5 m signal cable is included with each flowmeter. If a cable longer than 5 m is required, refer to the ordering information for the sensor.

Coil supply cable

Is required to connect the flowmeter sensor to the transmitter. For EMC reasons, the 2-wire cable is shielded. A 5 m cable is included with each flowmeter. If a cable longer than 5 m is required, refer to the ordering information for the sensor.

... Transmitter

Forward flow/reverse flow measurement

Flow direction is indicated by direction arrows in the display and over the contact for external signaling. The contact output can also transmit this information.

Display

4-line, illuminated graphic display. To improve readability, the flow information can be displayed on two lines with larger characters. This allows the individual flowrate and output values to be displayed. Non-switching measured value presentation on dot-matrix display with max. 4 × 16 characters. A plaintext diagnostic display opens automatically when the system detects an error. An alarm condition can also be signaled via contact output.

Data backup

Via FRAM (Ferroelectric Nonvolatile Random Access Memory), all data over 10 years old is stored (without power supply) in the event of shut-off or failure of the line voltage. Additional security is provided by a serial FRAM installed in the transmitter and on the external connection board in which the parameter settings and process information are stored. This makes it easy to replace a transmitter – without parameterization – by simply uploading the stored data from the external FRAM.

Flow totalization

The flow is totalized in engineering units. The limits for the pulse value can be set, are dynamic and depend on the measuring range (Q_{max}) setting as well as the totalizer units selected. The limits are a min. (0.00016 Hz) and max. pulse frequency (5 KHz). Totalizer values for the forward and reverse flow can be displayed simultaneously when configuring the 'Display' parameter.

Parameter configuration

The display supports several languages (German, English, French, Finnish, Swedish, Italian, Spanish, Dutch or Turkish), and information can be entered using the three buttons in the dialog or via a communication interface with a PC, HART® protocol, PROFIBUS® or FOUNDATION Fieldbus®. The magnet stick can also be used to configure the flowmeter with the front door closed. Position the magnet stick over the magnet icons on the display cover.

Alarm signaling

A max-min alarm can be used with the transmitter. The max. and min. limit values can be set in the range from 0 to 103 % of the flow rate. When the flowrate is outside the alarm limits, an error message is displayed in the upper line and a contact is triggered. The contact output can also transmit this information.

Wiring error

Monitoring of magnet coil or electrode circuits for short circuits or wire breaks.

Isolation of input/output

The current output, pulse output, contact input and contact output are electrically isolated from the input circuit and from each other.

Retrofitting

The transmitter with all its functions can also be used with older model electromagnetic flowmeters. The appropriate model number must be selected during parameter setting of the transmitter. It is also possible to use the transmitter with model 10D1422 flowmeters. A special FRAM (Cs = 100 %, Cz = 0 %) is required when retrofitting (see ordering information for the transmitter) and applies for nominal diameter range DN 3 to DN 1000 (1/10 to 40") in low voltage design only.

Extended diagnostic functions

Recorded parameters / fingerprints

Cyclical (10 sec to 7 days) or manual acquisition of parameters.

The data sets are stored in the transmitter FRAM (with time stamp / operating hours counter). A maximum of 10 sets can be stored. When the eleventh record is stored, the oldest data set is overwritten automatically.

Magnet coil circuit	AC voltage
	AC
	DC resistance (primary value for temperature)
	Temperature
	Insulation resistance (ground)
Electrode circuit	DAC value (primary value for coil current)
	Magnetic linearity
	Electrode voltage E1 (primary value for electrode balance)
	Electrode voltage E2 (primary value for electrode balance)
	Electrode balance
Quality (signal-to-noise ratio)	

The parameters can be checked for min.-max. errors. If the value is above or below the specified limit, a diagnostic error or warning, depending on the configuration, is triggered. The 'fingerprint' database integrated in the transmitter allows you to easily compare the values at the time of factory calibration or commissioning, for example, with the currently recorded values.

Users can store up to three different fingerprint data sets (commissioning, product1, product2) in the fingerprint database. The default fingerprint (optional) cannot be overwritten.

Detectable error states

Monitoring of ...	Detection of ...
Coil current / coil voltage / DAC value	Changes in the driver or coil circuit.
Coil resistance	Changes in coil circuit, e.g., fine short.
Coil temperature	Risk of overheating due to fluid.
Coil insulation resistance	Problems with the coil insulation. Can be caused, e.g., by dampness in the flowmeter sensor or in the connection box.
Linearity of magnetic circuit	External magn. field interference on the EMF, resulting in loss of accuracy.
Signal quality (signal-to-noise ratio)	Changes in fluid, e.g., gas bubbles, increased/reduced amount of solids.
Electrode balance	Distorted flow profile, e.g., due to improper installation. Detect interference in electrode circuit, e.g., failure of electrode due to insulating coating or a collapsed liner (vacuum shock).

Backward compatibility

The transmitter is suitable for connecting to flowmeter sensors over 20 years old. Occasionally, an adapter board may be required (for details, see the FSM4000 operating instructions).

The following flowmeter sensors are supported: DS21, DS21F, DS41F, 10DS3111 (A-E), 10DI1425, 10D1422, 10D1462, 10D1472

... Transmitter

Inputs/Outputs

DC output (terminals 31, 32)

The following functions can be selected in the software:

- 0 to 20 mA load $\leq 560 \Omega$
- 4 to 20 mA load $\leq 560 \Omega$
- 0 to 10 mA load $\leq 1120 \Omega$
- 2 to 10 mA load $\leq 1120 \Omega$

Switch output (terminals 41, 42)

The following functions can be selected in the software:

- Forward/reverse flow direction signal
- Flow limit alarm (max. or min.)
- Collective alarm
- Empty meter tube

The contact output can be configured as normally open or normally closed.

Optoelectronic coupler

- 'closed': $0 \text{ V} \leq U_{\text{CEL}} \leq 2 \text{ V}$, $2 \text{ mA} \leq I_{\text{CEL}} \leq 220 \text{ mA}$
- 'open': $16 \text{ V} \leq U_{\text{CEH}} \leq 30 \text{ V}$, $0 \text{ mA} \leq I_{\text{CEH}} \leq 2 \text{ mA}$

Scaled pulse output (terminals 51, 52)

Maximum totalizer frequency 5 kHz. Pulse value per physical unit from 0.001 to 1000 / unit selectable in the software. The pulse width can be configured from 0.100 to 2000 ms. The version (active, passive) can be changed via jumpers.

Active

Voltage pulse 24 V rectangular

- Load $\geq 150 \Omega$
pulse width $\leq 50 \text{ ms}$, max. pulse frequency $\leq 3 \text{ Hz}$,
- Load $\geq 500 \Omega$
pulse width $\geq 0.1 \text{ ms}$, max. pulse frequency: 5 kHz.

Passive (optoelectronic coupler)

- 'closed': $0 \text{ V} \leq U_{\text{CEL}} \leq 2 \text{ V}$, $2 \text{ mA} \leq I_{\text{CEL}} \leq 220 \text{ mA}$
- 'open': $16 \text{ V} \leq U_{\text{CEH}} \leq 30 \text{ V}$, $0 \text{ mA} \leq I_{\text{CEH}} \leq 2 \text{ mA}$

Digital communication

HART® protocol

The device is registered with the HART Communication Foundation.

Note

The HART® protocol is an unsecured protocol, as such the intended application should be assessed to ensure that these protocols are suitable before implementation.

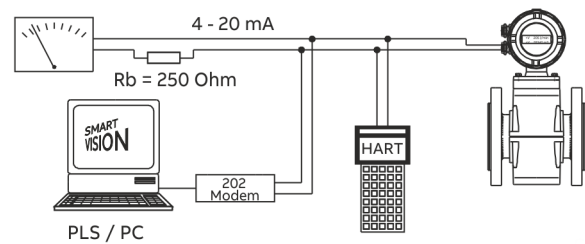

Figure 31: HART communication

HART protocol

Configuration	Directly on the device Software DAT200 Asset Vision Basic (+ HART-DTM)
Transmission	FSK modulation on current output 4 ... 20 mA according to Bell 202 Standard
Max. signal amplitude	1.2 mAss
Current output load	Min. 250 Ω , max. = 560 Ω
Cable	AWG 24 twisted
Max. cable length	1500 m
Baud rate	1200 baud
Display	Log. 1: 1200 HZ Log. 0: 2200 Hz

For additional information, see the separate interface description.

System integration

In conjunction with the DTM (Device Type Manager) available for the device (software version B.10 and higher), communication (configuration, parameterization) can occur with the corresponding framework applications according to FDT 1.21 (DAT200 Asset Vision Basic).

Other tool/system integrations (e.g., Emerson AMS/Siemens S7) are available upon request.

A free of charge version of the DAT200 Asset Vision Basic framework application for HART® or PROFIBUS is available upon request.

The required DTMs are contained on the DAT200 Asset Vision Basic DVD or in the DTM Library. They can also be downloaded from www.abb.com/flow.

PROFIBUS PA protocol

The interface conforms to Profile 3.0 (PROFIBUS standard, EN 50170, DIN 19245 [PRO91]).

Note

The PROFIBUS PA® protocol is an unsecured protocol, as such the intended application should be assessed to ensure that these protocols are suitable before implementation.

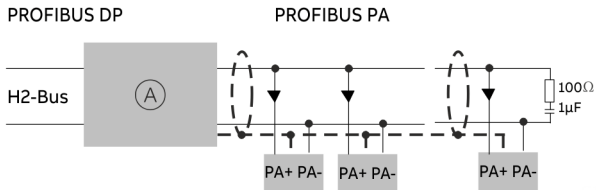

(A) Segment coupler (incl. bus supply and termination)

Figure 32: Example for PROFIBUS PA connection

PROFIBUS PA ID No.:	0x078C
Alternative Standard-Ident-No.	0x9700 or 0x9740
Configuration	Directly on the device Software DAT200 Asset Vision Basic (+ PROFIBUS PA-DTM)
Transmission signal	Acc. to IEC 61158-2
Cable	Shielded, twisted cable (acc. to IEC 61158-2, types A or B are preferred)

Bus topology

- Tree and / or line structure.
- Bus connection: Passive at both ends of the main bus line (RC element $R = 100 \Omega$, $C = 1 \mu F$).

Voltage / current consumption

- Mean current consumption: 10 mA.
- In the event of an error, the FDEfunction (= Fault Disconnection Electronic) integrated in the device makes sure that the current consumption cannot exceed a maximum of 13 mA.
- The upper current limit is restricted electronically.
- The voltage on the bus line must lie in the range of 9 to 32 V DC

Bus address

In the case of devices with a PROFIBUS PA interface, check the bus address prior to commissioning. If no specifications exist to the contrary, the address is set to 126. During commissioning, the address must be set to a valid value in the range 0 to 125.

System integration

Use of PROFIBUS PA profile B, B3.0 ensures interoperability and interchangeability of units. Interoperability means that devices from different manufacturers can be physically connected to a bus and are communication-ready.

The devices can be interchanged without having to reconfigure the process control system.

To support interchangeability, three different GSD files (equipment master data) are provided, which can be integrated in the system.

For additional information, see the separate interface description.

The manufacturer-specific GSD file ABB_078C can be downloaded from <http://www.abb.com/flow>.

The standard GSD files PA1397xx.gsd can be downloaded from <http://www.profibus.com>.

... Transmitter

FOUNDATION Fieldbus® (FF)

Note

The FOUNDATION Fieldbus® protocol is an unsecured protocol, as such the intended application should be assessed to ensure that these protocols are suitable before implementation.

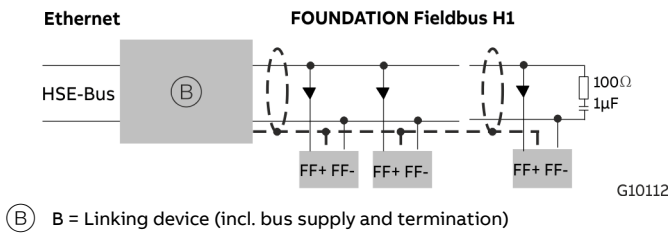

(B) B = Linking device (incl. bus supply and termination)

Figure 33: Example for FOUNDATION Fieldbus connection

FF interface	Compliant with FF standard 890/891 and FF 902/90
Interoperability test campaign no.	IT 027200 (ITK 4.6)
Manufacturer ID	0x000320
Device ID	0x0017
Configuration	<ul style="list-style-type: none"> • Directly on the device • Via services integrated in the system • National configurator
Transmission signal	Acc. to IEC 61158-2

Bus topology

- Tree and / or line structure.
- Bus connection: Passive at both ends of the main bus line (RC element $R = 100 \Omega$, $C = 1 \mu\text{F}$).

Voltage / current consumption

- Mean current consumption: 10 mA.
- In the event of an error, the FDEfunction (= Fault Disconnection Electronic) integrated in the device makes sure that the current consumption cannot exceed a maximum of 13 mA.
- The upper limit of the current is electronically restricted.
- The voltage on the bus line must lie in the range of 9 to 32 V DC

Bus address

The bus address is automatically assigned or can be set in the system manually.

Addresses are detected using a unique combination of manufacturer ID, device ID, and device serial number.

System integration

The following are required:

- DD (Device Description) file, which includes the device description.
- CFF (Common File Format) file is required for engineering the segment. Engineering can be performed online or offline.

For additional information, see the separate interface description.

The files required for operation can be downloaded from <http://www.fieldbus.org>.

Electrical connections

Standard DN 3 to DN 1000 ($\frac{1}{4}$ " to 40")

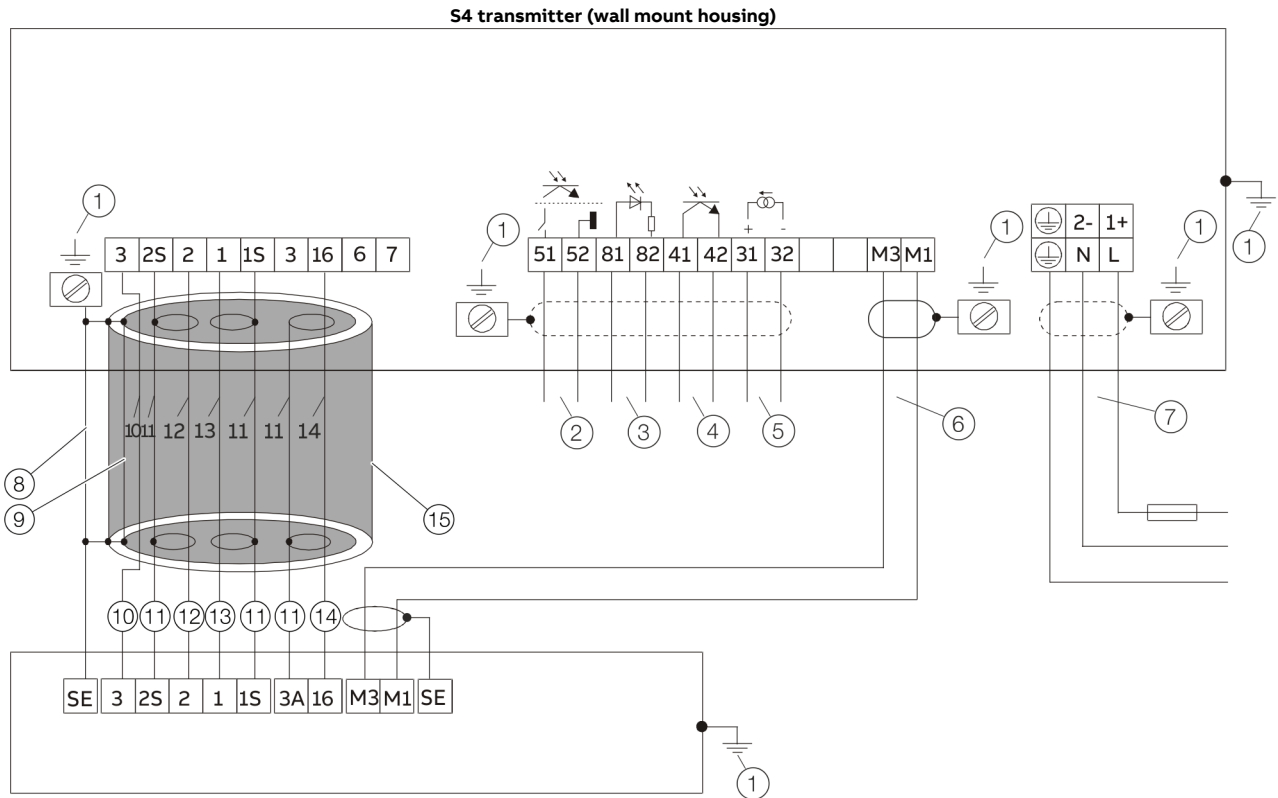

Sensor

- | | |
|--|--|
| ① Functional ground (busbar) | ⑧ Steel shielding |
| ② Pulse output ¹⁾ | ⑨ Aluminum foil |
| ③ Switch input ¹⁾ | ⑩ Yellow |
| ④ Switch output ¹⁾ | ⑪ Shield |
| ⑤ Current output ¹⁾ | ⑫ Blue |
| ⑥ Magnetic coil cable:
shielded 2 x 1 mm ² CE type 227 TEC 74
ABB order no. D173D147U01, 10 m included in shipment, standard | ⑬ Red |
| ⑦ Power supply
Low voltage: 100 ... 230 V AC, terminals L, N, ⊕
Extra-low voltage: 20.4 ... 26.4 V AC;
20.4 ... 31.2 V DC
Terminals 1+, 2-, ⊕
Frequency: 47 Hz ≤ f ≤ 53 Hz; 50 Hz power supply
56 Hz ≤ f ≤ 64 Hz; 60 Hz power supply | ⑭ White |
| | ⑮ Shielded signal cable:
ABB order no. D173D025U01, 10 m included in delivery |

Figure 34: Electrical connection sensor standard DN 10 ... DN 1000 ($\frac{1}{4}$ " ... 40")

1) See the chapter 'Connection examples for peripherals' in the operating instruction and/or on the data sheet

Note

We recommend that shielded output cables be used with the shields connected to the functional ground at one end.

... Transmitter

With preamplifier DN 3 to DN 1000 ($\frac{1}{16}$ to 40")

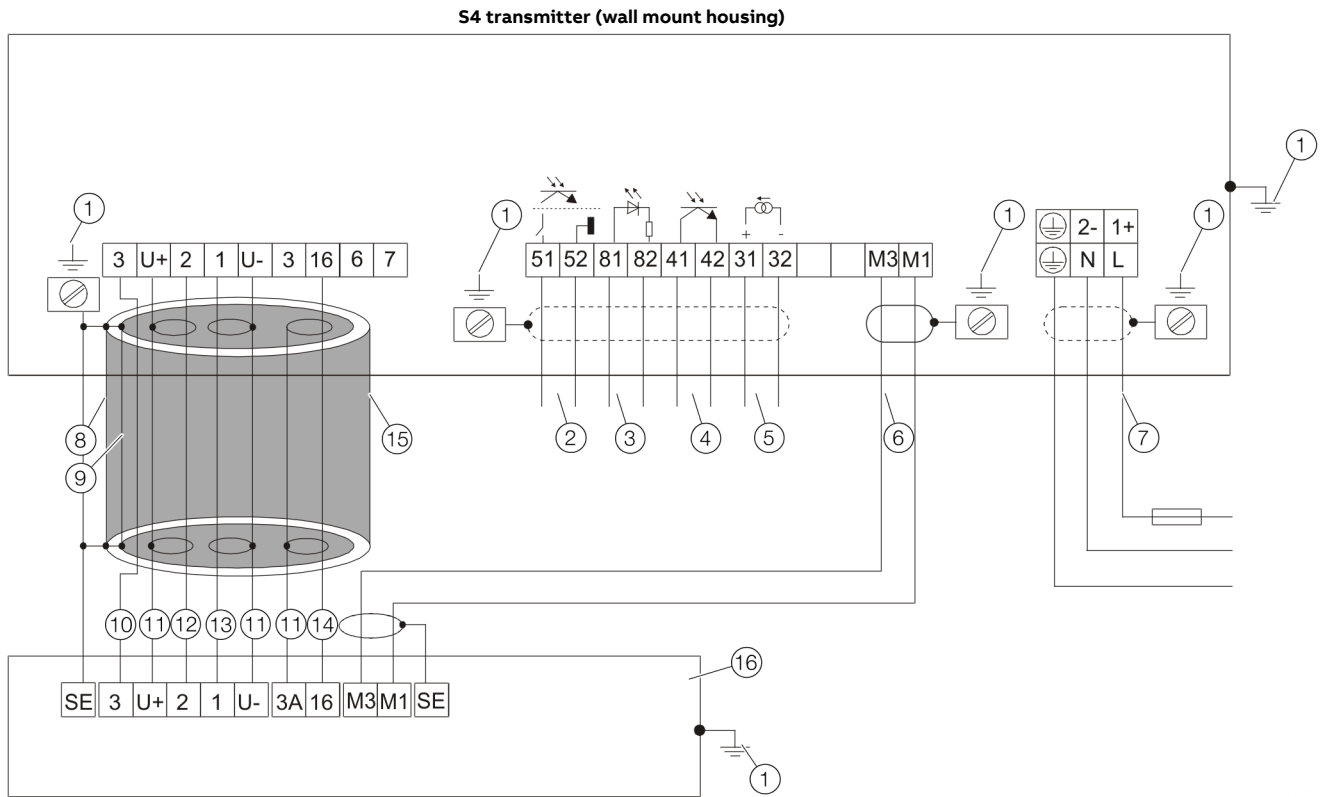

- | | |
|---|--|
| ① Functional ground (busbar) | ⑧ Steel shielding |
| ② Pulse output ¹⁾ | ⑨ Aluminum foil |
| ③ Switch input ¹⁾ | ⑩ Yellow |
| ④ Switch output ¹⁾ | ⑪ Shield |
| ⑤ Current output ¹⁾ | ⑫ Blue |
| ⑥ Magnetic coil cable:
shielded 2 x 1 mm ² CE type 227 TEC 24
ABB order no. D173D147U01, 10 m included in shipment, standard | ⑬ Red |
| ⑦ Power supply
Low voltage: 100 to 230 V AC, terminals L, N, ⊕
Extra-low voltage: 20.4 to 26.4 V AC;
20.4 to 31.2 V DC
Terminals 1+, 2-, ⊕
Frequency: 47 Hz ≤ f ≤ 53 Hz; 50 Hz power supply
56 Hz ≤ f ≤ 64 Hz; 60 Hz power supply | ⑭ White |
| | ⑮ Shielded signal cable: ABB order no. D173D025U01,
10 m included in delivery |
| | ⑯ with preamplifier (always at DN 3 to DN 8 [$\frac{1}{16}$ to $\frac{5}{16}$ "]) |

Figure 35: Electrical connection sensor with preamplifier DN 3 to DN 1000 ($\frac{1}{16}$ to 40"), transmitter field mount housing

1) See the chapter 'Connection examples for peripherals' in the operating instruction and/or on the data sheet

Note

- We recommend that shielded output cables be used with the shields connected to the functional ground at one end.
- If the sensor is equipped with a preamplifier for low conductivity or in nominal diameter range of DN 3 to DN 8 ($\frac{1}{16}$ to $\frac{5}{16}$ "), the shieldings of the signal wires must be connected to terminals U+ and U- on both the sensor and the transmitter.

**Retrofit for model 10D1422: DN 3 to DN 1000 (1/10 to 40"); model 10DI1425 and 10DS3111A-E:
DN 500 to DN 1000 (20 to 40")**

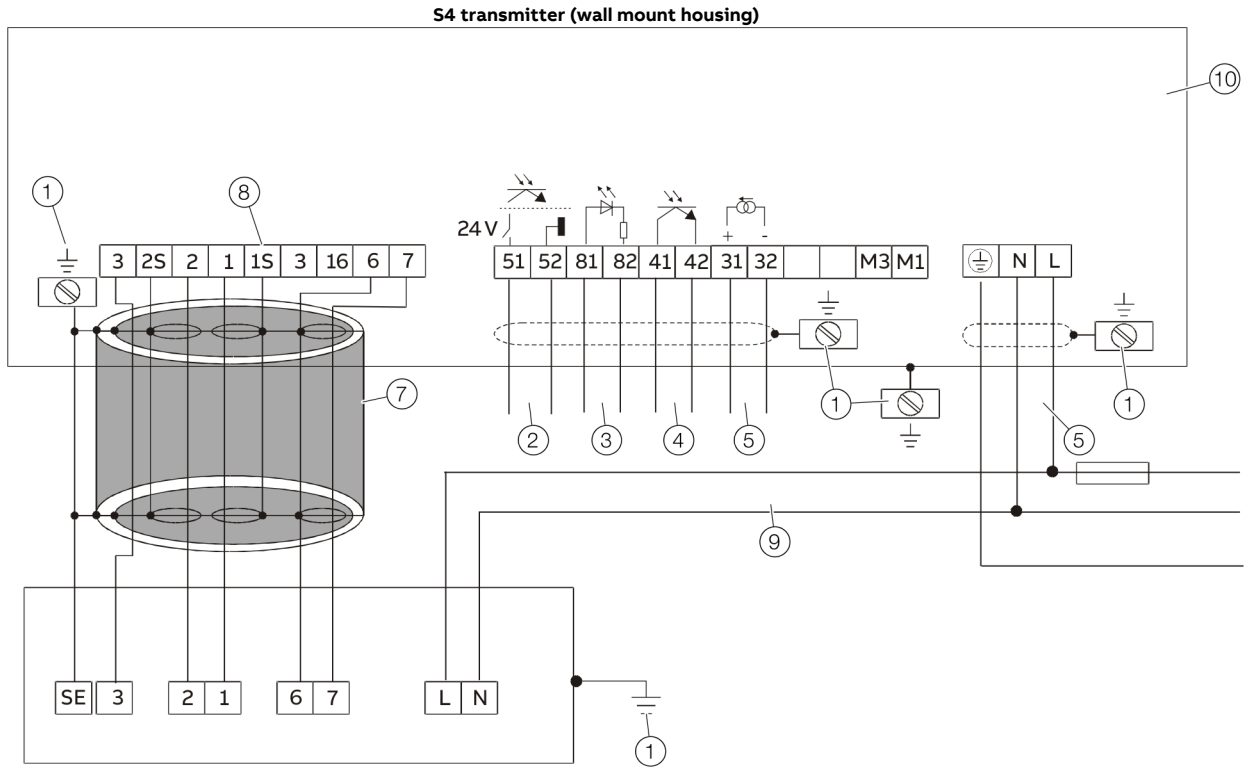

① Functional ground (busbar)

② Pulse output¹⁾

③ Switch input¹⁾

④ Switch output¹⁾

⑤ Current output¹⁾

⑥ Power supply

Low voltage: 100 to 230 V AC, terminals L, N, ⊕

Frequency: 47 Hz ≤ f ≤ 53 Hz; 50 Hz power supply

56 Hz ≤ f ≤ 64 Hz; 60 Hz power supply

Sensor

⑦ Shielded signal cable: ABB order no. D173D025U01
or incorporate in existing wiring

⑧ Reference cable:

Only for connection to model 10D1422

Close terminals: 6,7 and hook switch S903

⑨ Magnetic coil supply:

Magnet coil supply via supply power

⑩ Terminal board: D685A1020U03

Figure 36: Sensor standard DN 3 to DN 1000 (1/10 to 40"), transmitter field mount housing

1) See the chapter 'Connection examples for peripherals' in the operating instruction and/or on the data sheet

Note

We recommend that shielded output cables be used with the shields connected to the functional ground at one end.

... Transmitter

DN 3 to DN 1000 ($\frac{1}{4}$ " to 40") with PROFIBUS PA / FOUNDATION Fieldbus

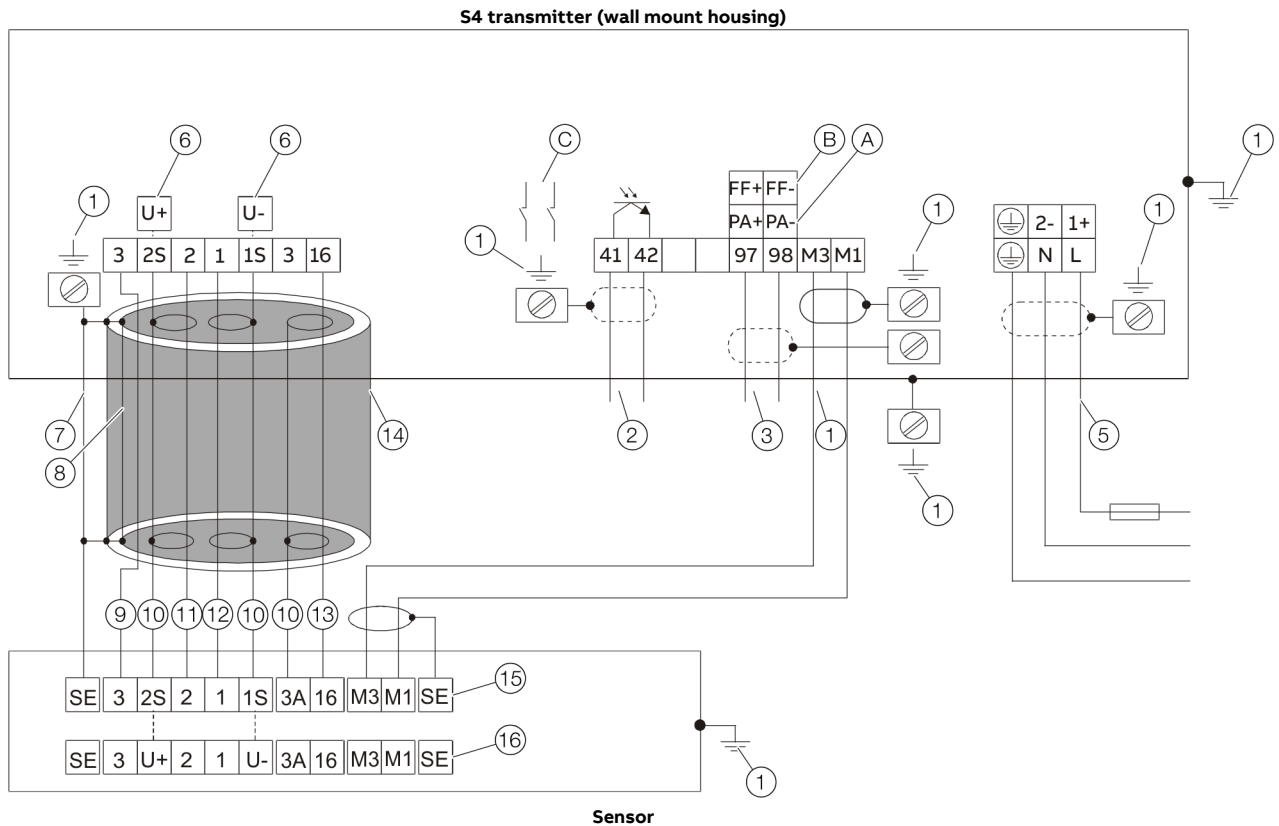

- | | |
|--|---|
| <p>① Functional ground (busbar)</p> <p>② Switch output (see the section 'Connection examples for peripherals' in the operating instruction and/or on the data sheet)</p> <p>③ Digital communication</p> <p> (A) PROFIBUS PA design conforming to IEC 61158-2 (Profile 3.0)
 U = 9 to 32 V, I = 10 mA (normal operation)
 I = 13 mA (in the event of error/FDE)
 Terminals: 97/98, PA+/PA-
 (see the chapter 'Connecting via M12 plug' in the operating instruction and/or on the data sheet)</p> <p> (B) FOUNDATION Fieldbus design conforming to IEC 61158-2
 U = 9 to 32 V, I = 10 mA (normal operation)
 I = 13 mA (in the event of error/FDE)
 Terminals: 97/98, FF+/FF-
 (see the chapter 'Connecting via M12 plug' in the operating instruction and/or on the data sheet)</p> <p> (C) Bus termination with installed bus termination components with hook switches closed</p> <p>④ Magnetic coil cable:
 shielded 2 x 1 mm² CE type 227 TEC 74
 ABB order no. D173D147U01, 10 m included in shipment, standard</p> | <p>⑤ Power supply
 Low voltage: 100 to 230 V AC, terminals L, N, \oplus
 Extra-low voltage: 20.4 ...26.4 V AC;
 20.4 to 31.2 V DC
 Terminals 1+, 2-, \oplus
 Frequency: 47 Hz \leq f \leq 53 Hz; 50 Hz power supply
 56 Hz \leq f \leq 64 Hz; 60 Hz power supply</p> <p>⑥ Shielded signal cable:
 Power supply for flowmeter sensor with preamplifier
 Terminals U+, U- instead of 2S and 1S in standard unit</p> <p>⑦ Steel shielding</p> <p>⑧ Aluminum foil</p> <p>⑨ Yellow</p> <p>⑩ Shield</p> <p>⑪ Blue</p> <p>⑫ Red</p> <p>⑬ White</p> <p>⑭ Shielded signal cable: ABB order no. D173D025U01, 10 m, included in shipment</p> <p>⑮ Without preamplifier</p> <p>⑯ With preamplifier (always at DN 1 to DN 8 [$\frac{1}{16}$ to $\frac{5}{16}$"])</p> |
|--|---|

Figure 37: Electrical connection transmitter S4 with PROFIBUS PA / FOUNDATION Fieldbus

Note

- We recommend that shielded output cables be used with the shields connected to the functional ground at one end.
- If the sensor is equipped with a preamplifier for low conductivity or in nominal diameter range of DN 1 to DN 8 ($\frac{1}{16}$ to $\frac{5}{16}$ "), the shieldings of the signal wires must be connected to terminals U+ and U- on both the sensor and the transmitter.

Connection examples for peripherals (incl. HART)

Current output

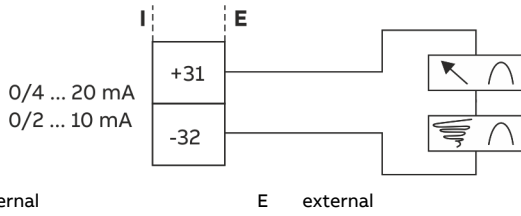

I internal E external

Figure 38: Current output active with / without HART protocol (4 ... 20 mA)

Current output active with / without HART protocol (4 ... 20 mA)	
Terminals	31, 32
Current output	can be selected via software
Function	Active
	0/4 ... 20 mA ($0 \Omega \leq R_B \leq 560 \Omega$)
	0/2 ... 10 mA ($0 \Omega \leq R_B \leq 1120 \Omega$)
	(for HART only 4 ... 20 mA)

Switch input

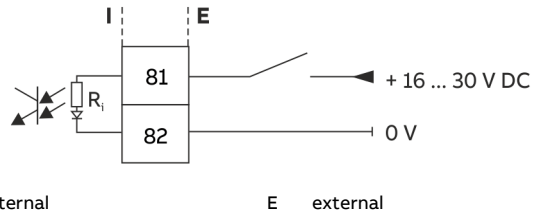

I internal E external

Figure 40: Switch input for external totalizer reset and external zero return

Switch input, passive	
Terminals	81, 82
Current output	can be selected via software
Function	Passive
	• 'On':
	16 V \leq UKL \leq 30 V
	• 'Off':
	0 V \leq UKL \leq 2 V
	Ri = 2 k Ω

Switch output

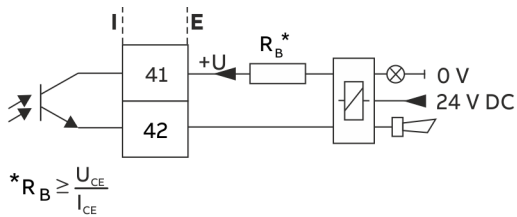

I internal E external

Figure 39: Switch output for system monitoring, Max. / Min. alarm for empty meter tube or forward / reverse signal

Switch output for system monitoring	
Terminals	41, 42
Current output	can be selected via software
Function	Passive
	• 'closed':
	0 V \leq UCEL \leq 2 V, 2 mA \leq ICEL \leq 220 mA
	• 'open':
	16 V \leq UCEH \leq 30 V, 0 mA \leq ICEH \leq 2 mA

Note

Horn and alarm light are shown only as examples. Other suitable devices such as bells, sirens, buzzers, etc., can also be used.

... Transmitter

Pulse output

Active pulse output

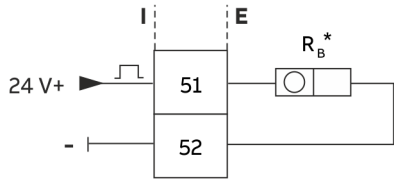

Pulse output, passive, optocoupler

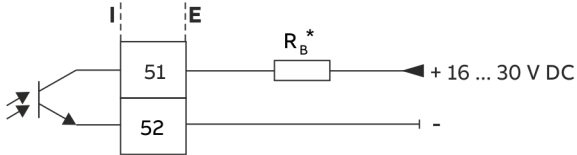

$$*R_B \geq \frac{U_{CE}}{I_{CE}}$$

I internal E external

Figure 41: Pulse output, active and passive, optoelectronic coupler

Current output active with / without HART protocol (4 ... 20 mA)

Terminals	51, 52
Current output	can be selected via software
Operating mode	Active / passive, selectable via jumper (see 'Commissioning' chapter in operating instruction)
f_{max}	5 kHz
f_{min}	0.00016 Hz
Adjustment range	Pulse / unit, pulse width (observe dynamic limits)
Function	Active <ul style="list-style-type: none"> • $150 \Omega \leq \text{load} < 10 \text{ k}\Omega$: pulse width $\leq 50 \text{ ms}$, max. pulse frequency $\leq 3 \text{ Hz}$, • $500 \Omega \leq \text{load} < 10 \text{ k}\Omega$: pulse width $\leq 0.1 \text{ ms}$, max. pulse frequency: 5 kHz Passive <ul style="list-style-type: none"> • 'closed': $0 \text{ V} \leq U_{CEL} \leq 2 \text{ V}$, $2 \text{ mA} \leq I_{CEL} \leq 220 \text{ mA}$ • 'open': $16 \text{ V} \leq U_{CEH} \leq 30 \text{ V}$, $0 \text{ mA} \leq I_{CEH} \leq 2 \text{ mA}$

PROFIBUS PA® / FOUNDATION Fieldbus®

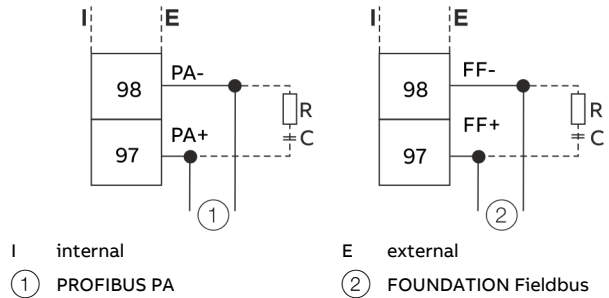

Figure 42: Digital communication PROFIBUS PA / FOUNDATION Fieldbus

The resistance R and condenser C form the bus termination. They must be installed when the device is connected to the end of the entire bus cable.

R = 100 Ω; C = 1 μF

Bus termination for S4 transmitter

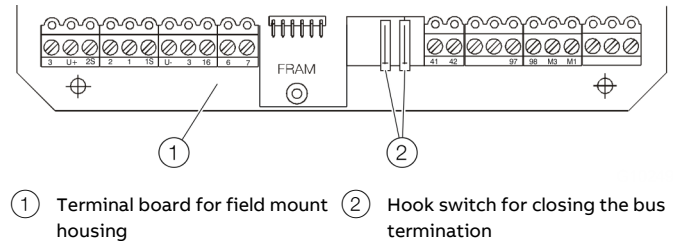
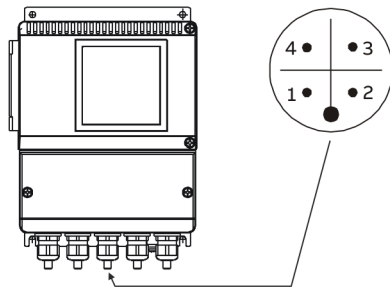

Figure 43: Bus termination

To terminate the bus if the instrument is at the end of the bus cable, the termination components in the S4 transmitter can be used. To do so, close both hook switches in the connection area of the transmitter.

Note

If the transmitter module is removed, bus termination is also canceled.

Connection via M12 plug (for PROFIBUS PA only)

Pin assignment (front view showing pin insert and pins)

1	PA+	3	PA-
2	nc	4	Shielding

Figure 44: M12 plug-in connector PROFIBUS PA

As an option, the bus can also be connected via an M12 plug instead of the cable gland (see order information for device). The device can be shipped completely prewired. For information about suitable connectors (type EPG300) and other accessories, refer to the data sheet 10/63.6.44 DE.

... Transmitter

Dimensions

Transmitter housing and suggested installation method

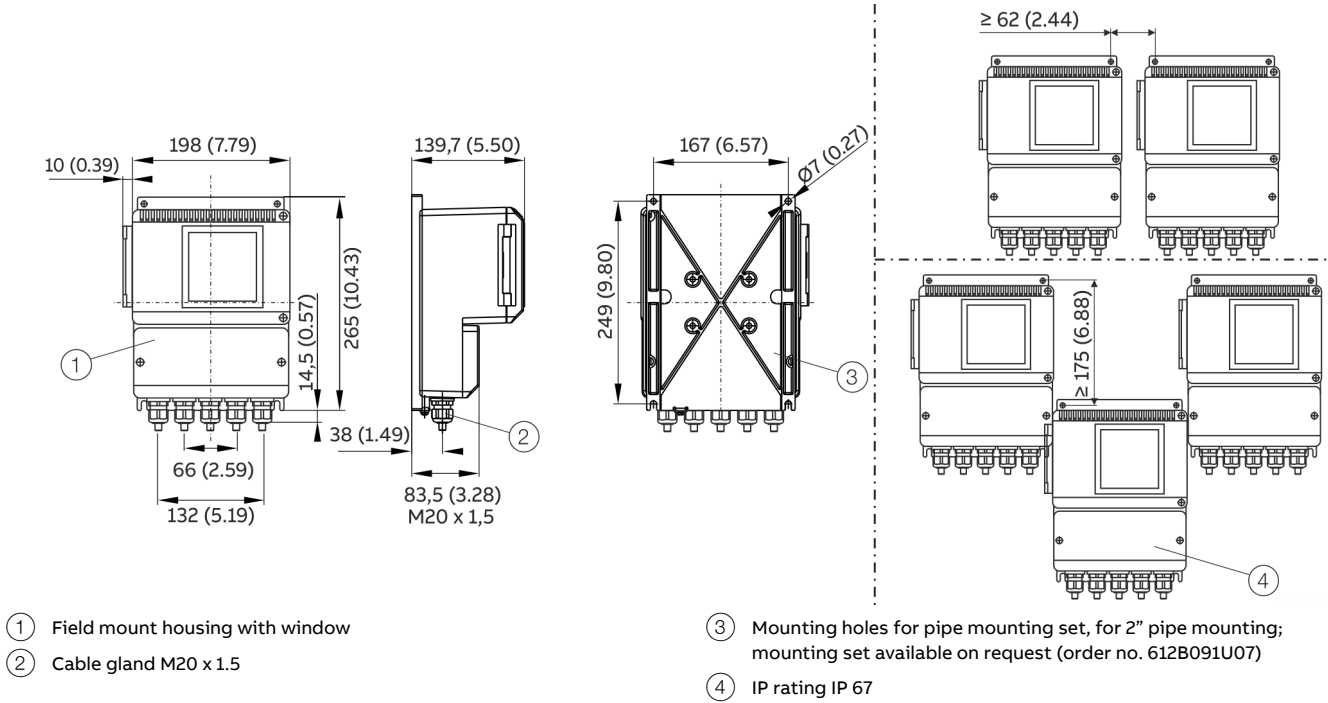

Figure 45: Dimensions transmitter housing – dimensions in mm (inch)

Ordering information

Accuracy 0.5% of rate, for FSM4000-SE21 / -SE41

Main order number										
FSM4000-S4 External Converter	S4-	X	X	X	XX	X	X	X	X	XX
Housing										
Field housing (cable gland M20 x 1.5)		A								
Field housing (cable gland 1/2 in. NPT)		B								
Power Supply										
100 ... 230 V AC				G						
16,8 ... 26,4 V AC / 16,8 ... 31,2 V DC				K						
Display										
Magnetic stick operation and display illuminated					A					
Input / Output Options										
Current output active + Pulse output active + Contact input + Contact output										01 ¹⁾
Current output active + Pulse output active + Contact input + Contact output + HART										02
Current output active + Pulse output passive + Contact input + Contact output										03 ¹⁾
Current output active + Pulse output passive + Contact input + Contact output + HART										04
Contact output + PROFIBUS PA										07
Contact output + FOUNDATION Fieldbus										08
Contact output + PROFIBUS PA with M12 plug										10
Others										99
Application										
Extended diagnostics										1
For Flowmeter Sensor										
SE2_, SE4_										1 ²⁾
DS2_, DS4_, 10DS3111, 10DI1425, 10D142										2 ³⁾
Certificates										
Standard										0
Name Plate Language / Type										
German / Adhesive foil										G
English / Adhesive foil										E
French / Adhesive foil										F
German / Stainless steel										J
English / Stainless steel										K
French / Stainless steel										L
Design Level / Software Level										
(Specified by ABB)										XX

1) Not with low voltage power supply (code K)

2) The external FRAM is in the terminal box of the associated flowmeter sensor on delivery

3) In this variant, the external FRAM already is plugged into the converter with the values Cz = 0 % and Cs = 100 %.

Continued on next page

... Transmitter

Additional order number

Additional order number		
FSM4000-S4 External Converter	XX	XXX
Language of Documentation		
German	M1	
English	M5	
Russian	MB	
Language package Western Europe / Scandinavia (Languages: FR, ES, DA, IT, NL, PT, SV, FI)	MW	
Language package Eastern Europe (Languages: EL, CS, ET, HU, HR, LT, LV, PL, SK, SL, RO, BG)	ME	
Others	MZ	
Other Usage Certifications		
Russia - metrological and EAC certificate		ED1

Installation set for 2" pipe mounting in field-mount housing



Figure 46: Part number: 3KXF081100L0001

Trademarks

FOUNDATION Fieldbus is a registered trademark of FieldComm Group, Austin, Texas, USA.

HART is a registered trademark of FieldComm Group, Austin, Texas, USA

PROFIBUS, PROFIBUS PA and PROFIBUS DP are registered trademarks of PROFIBUS & PROFINET International (PI)

Sales



Service



Notes



ABB Measurement & Analytics

For your local ABB contact, visit:
www.abb.com/contacts











For more product information, visit:
www.abb.com/flow

We reserve the right to make technical changes or modify the contents of this document without prior notice. With regard to purchase orders, the agreed particulars shall prevail. ABB does not accept any responsibility whatsoever for potential errors or possible lack of information in this document.

We reserve all rights in this document and in the subject matter and illustrations contained therein. Any reproduction, disclosure to third parties or utilization of its contents – in whole or in parts – is forbidden without prior written consent of ABB.



Our offering:

	Actuators and Positioners		Analytical Instruments
	Device Management, Fieldbus and Wireless		Flow Measurement
	Force Measurement		Level Measurement
	Natural Gas Measurement		Pressure Measurement
	Recorders and Controllers		Temperature Measurement

HMI – Automação e Instrumentação, Lda.

Travessa da Indústria, nº 111
4780-573 Santo Tirso
PORTUGAL

Tel. +351 252 850 501
Fax. +351 300 013 487

Web: www.hmi.pt

Email: hmi@hmi.pt