

hmi

high-accuracy
measurement
instruments

FICHA TÉCNICA DE PRODUTO

PRODUCT DATASHEET

HMI – Automação e Instrumentação, Lda.

Travessa da Indústria, nº 111
4780-573 Santo Tirso
PORTUGAL

Tel. +351 252 850 501
Fax. +351 300 013 487

Web: www.hmi.pt

Email: hmi@hmi.pt

ProcessMaster FEP610 Electromagnetic flowmeter

The new flowmeter:
The first choice for all industrial
standard applications.

Measurement made easy



ABB common look and feel

- Easy Set-up function
- Simple and intuitive configuration
- Through-the-glass configuration with capacitive switches
- Backlit, rotatable LCD display
- Configurable display pages

SensorApplicationMemory

- Secure storage of calibration and application specific data
- Quick change-out of transmitter without reprogramming

Verification und Online Diagnostic

- Easy to check based on Fingerprint Technology - the reference signature of the device
- Service Interval Monitoring. Message at end of service interval
- Function and Simulation routines for all outputs

Easy-to-understand diagnostic messages

- Continuous monitoring of sensor and transmitter integrity and process conditions
- Text in help menu in response to diagnostic results for fast and efficient error handling

One single transmitter fits all design types

- Integral mount design or remote mount design
- With or without LCD display
- Universal wide-range power supply

Easily customizable output signals

- Analog current output
- Two fully configurable digital outputs

Robust sensor design for rough environmental conditions

- Real-world proven
- Hermetically sealed flow sensor
- Optimal Protection against Condensation, vibration and corrosion

Ideally suited for industrial standard applications

- Industry optimized liner materials, resistant to abrasion, long-lasting
- Wide range of electrode materials, corrosion resistant for longest service life

Simplified Spare Parts Handling

- Common transmitter electronic results in significant cost reduction
- Simplified stock keeping

ProcessMaster FEP610

Electromagnetic flowmeter

The Company

ABB is an established world force in the design and manufacture of instrumentation for industrial process control, flow measurement, gas and liquid analysis and environmental applications. As a world leader in process automation technology our worldwide presence, comprehensive service and application oriented know-how make ABB a leading supplier of flow measurement products.

Introduction

Setting the standard for the process industry

ProcessMaster is designed specifically to meet the increased requirements on advanced flowmeters. The modular design concept offers flexibility, cost-saving operation and reliability whilst providing a long service life and exceptionally low maintenance.

Advanced diagnostic functions

The device monitors its integrity and operability continuously. When limits are exceeded, a corresponding alarm is flagged. Critical states are recognized at an early stage allowing to take appropriate measures.

As a result, productivity is increased and downtimes are avoided. The status messages are classified in accordance with the NAMUR recommendations.

In the event of an error, clear text messages appear on the display considerably simplifying and accelerating the troubleshooting procedure. This gives maximum safety for the process.

Intuitive, convenient navigation

The user-friendly interface allows quick and simple data entry for all process parameters.

“Easy Set-up” guides the operator step by step through the menu to set parameters as fast as possible. During configuration, the limit of each parameter is indicated on the display and invalid configurations rejected.

Universal transmitter - powerful and flexible

All product versions utilize a common electronic to lower inventory costs and spare parts.

This same cartridge can be deployed in integral and remote installations and features current, status and pulsed outputs. The backlit, graphical display can be easily rotated through 270° allowing field teams to customize the display that best fits their needs.

TTG (Through-the-glass) operation allows local operator interface to input short, quick data for all user specific parameters.

The universal ABB Human Machine Interface (HMI) simplifies operation, maintenance and training; thereby reducing cost of ownership and providing one common user experience.

Overview – models

Flowmeter sensor

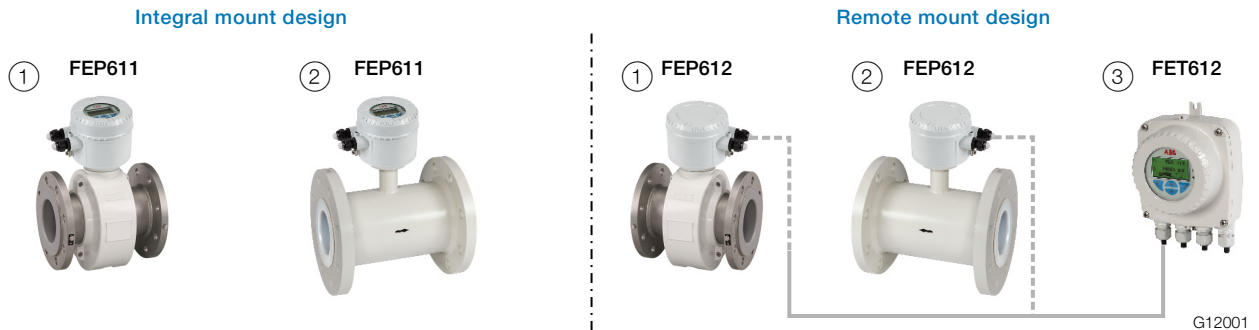

Fig. 1: Designs

① Flowmeter sensor, Design Level A (DN 3 ... 2000) ② Flowmeter sensor, Design Level B (DN 25 ... 600) ③ Remote transmitter

Flowmeter sensor	
Model	ProcessMaster FEP611, FEP612
Housing	Integral mount design, remote mount design
Measuring accuracy for liquids	0.5 % of measured value
Permissible measuring medium temperature T_{medium}	-25 ... 130 °C (-13 ... 266 °F)
Minimum conductivity	> 20 $\mu\text{S}/\text{cm}$ (20 $\mu\text{S}/\text{cm}$ for demineralized water)
Nominal pressure rating	PN 10 ... 40; ASME CL 150, 300; JIS 10K
Nominal diameter	DN 3 ... 2000 (1/10 " ... 80 ")
Process connection	Flange ¹⁾ according to DIN, ASME, JIS
Process connection material	Steel, cast iron, stainless steel
Liner material	Hard rubber (DN 15 ... 2000), soft rubber (DN 50 ... 2000), PTFE (DN 10 ... 600), PFA (DN 3 ... 200), ETFE (DN 25 ... 600)
Electrode material	Stainless steel, Hastelloy B, Hastelloy C, platinum-iridium, tantalum, titanium
IP rating	Integral mount design: IP 65 / IP 67 Remote mount design: IP 65 / IP 67 / IP 68 (sensor only)
Approvals	
Pressure Equipment Directive 2014/68/EU	Conformity assessment in accordance with category III, fluid group 1
CRN (Canadian Reg.Number)	On request
Further approvals	At www.abb.com/flow or on request.

1) For information on flange thicknesses, see the chapter "Dimensions" on page 17.

ProcessMaster FEP610

Electromagnetic flowmeter

Transmitter	
Model	FET612
Housing	Integral mount design (see Fig. 1), remote mount design.
IP rating	IP 65 / IP 67
Cable length	Maximum 50 m (164 ft), remote mount design only
Power supply	100 ... 240 V AC (-15 / +10 %), 24 ... 48 V DC (-10% / +10 %)
Outputs	Current output: 4 ... 20 mA, active Digital output 1: passive, configurable as pulse, frequency or switch output Digital output 2: passive, configurable as pulse or switch output
Local display	Configurable graphical display (option)
Approvals	
— Further approvals	At www.abb.com/flow or on request.

Measuring principle

Measurements performed by the electromagnetic flowmeter are based on Faraday's law of induction. A voltage is generated in a conductor when it moves through a magnetic field.

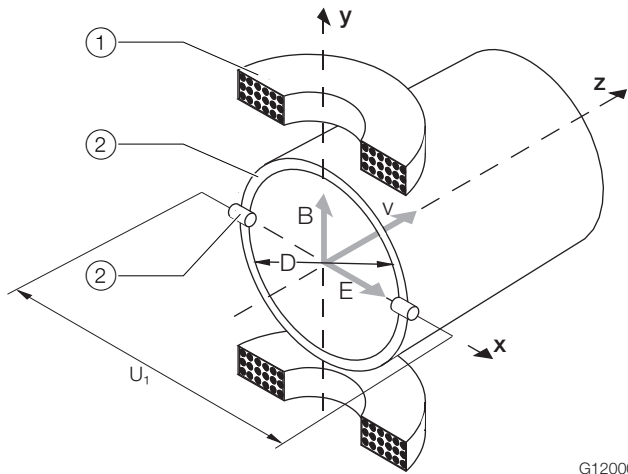

G12000

Fig. 2: Electromagnetic flowmeter schematic

① Magnet coil ② Measuring tube in electrode plane ③ Signal electrode

$$U_1 \sim B \times D \times v \quad q_v = \frac{D^2 \times \pi}{4} \times v \quad U_1 \sim q_v$$

U_1 Signal voltage v Average flow velocity
 B Magnetic induction q_v Volume flow
 D Electrode spacing

This principle is applied to a conductive fluid in the measuring tube through which a magnetic field is generated perpendicular to the flow direction (see Fig. 2). The voltage induced in the fluid is measured by two electrodes located diametrically opposite each other. This signal voltage is proportional to the magnetic induction, the electrode spacing and the average flow velocity. Considering that the magnetic induction and the electrode spacing are constant values, a proportionality exists between the signal voltage U_E and the average flow velocity. From the equation for calculating the volume flowrate, it follows that the signal voltage is linearly proportional to the volume flowrate. The induced voltage is converted by the transmitter to standardized, analog and digital signals.

Flowmeter sensor

Measuring accuracy

Reference conditions

According to EN 29104

Measuring medium temperature	20 °C (68 °F) ±2 K
Ambient temperature	20 °C (68 °F) ±2 K
Power supply	Nominal voltage acc. to name plate U = ±1 %, Frequency f = ±1 %
Installation condition	– Upstream >10 x DN, straight section – Downstream >5 x DN, straight section
Warm-up phase	30 min

Measuring error and repeatability

Measuring error

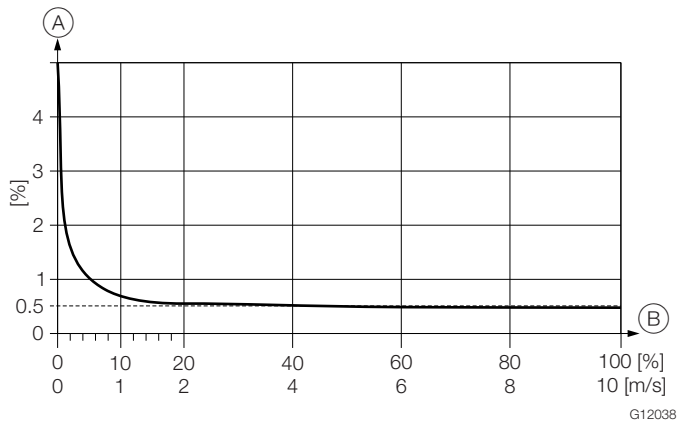

Fig. 3: Measuring error

- (A) Accuracy ± of measured value in %
 (B) Flow velocity v in m/s, Q / Q_{max}DN in %

Impulse output

±0.5 % of measured value, ±0.02 % Q_{max}DN¹⁾

1) Q_{max}DN: See table in chapter "Measuring range table" on page 8.

Current output

Same as pulse output plus ±0.1 % of measured value ±0.01 mA

Repeatability, response time

Repeatability	≤ 0.11 % of measured value, t _{meas} = 100 s, v = 0.5 ... 10 m/s
Response time ¹⁾	As step function 0 ... 99 % 5 τ ≥ 200 ms at 25 Hz excitation frequency 5 τ ≥ 400 ms at 12.5 Hz excitation frequency 5 τ ≥ 500 ms at 6.25 Hz excitation frequency

1) Of current output with damping of 0.02 seconds.

ProcessMaster FEP610

Electromagnetic flowmeter

Permitted pipe vibration

In accordance with EN 60068-2-6.

Applicable to sensors in remote mount design and sensors in integral mount design.

- Maximum deflection: 0.15 mm (0.006 inch) in the 10 ... 58 Hz range
- Maximum acceleration: 2 g, in the 58 ... 150 Hz range

IP rating

- IP 65 / IP 67 in accordance with EN 60529
- IP 68 in accordance with EN 60529 (for remote mount design only)

Signal cables

For remote mount design only.

The maximum signal cable length between flowmeter sensor and transmitter is 50 m (164 ft).

A 5 m (16.4 ft) cable is included in the scope of delivery.

If more than 5 m (16.4 ft) is required, the cable can be ordered separately (Part no. D173D031U01).

Temperature data

Storage temperature range

-30 ... 70 °C (-22 ... 158 °F)

The temperature range offered by the device is dependent on a number of different factors.

These factors include the measuring medium temperature T_{medium} , the ambient temperature T_{amb} , the operating pressure P_{medium} , the liner material and the approvals for the explosion protection.

Maximum permissible cleaning temperature

CIP medium	Liner material	Cleaning temperature
Steam	PTFE, PFA	150 °C (302 °F)
Cleaning fluid	PTFE, PFA	140 °C (284 °F)

- The specified cleaning temperature applies for a maximum ambient temperature of 25 °C (77 °F).
If the ambient temperature is > 25 °C (> 77 °F), the difference to the actual ambient temperature must be subtracted from the maximum cleaning temperature.
- The specified cleaning temperature may be applied for a maximum of 60 minutes.

Ambient temperature as a function of measuring medium temperature Integral mount design

Liner material	Flange material	Ambient temperature range ($T_{amb.}$)		Measuring medium temperature range (T_{medium})	
		Minimum	Maximum	Minimum	Maximum
Hard rubber	Steel	-10 °C (14 °F)	60 °C (140 °F)	-10 °C (14 °F)	85 °C (185 °F) ²⁾
				-5 °C (23 °F) ¹⁾	80 °C (176 °F) ¹⁾
Hard rubber	Stainless steel	-15 °C (5 °F)	60 °C (140 °F)	-15 °C (5 °F)	85 °C (185 °F) ²⁾
				-5 °C (23 °F) ¹⁾	80 °C (176 °F) ¹⁾
Soft rubber	Steel	-10 °C (14 °F)	60 °C (140 °F)	-10 °C (14 °F)	60 °C (140 °F)
Soft rubber	Stainless steel	-15 °C (5 °F)	60 °C (140 °F)	-15 °C (5 °F)	60 °C (140 °F)
PTFE	Steel	-10 °C (14 °F)	60 °C (140 °F)	-10 °C (14 °F)	85 °C (185 °F)
		-10 °C (14 °F)	30 °C (86 °F)	-10 °C (14 °F)	130 °C (266 °F)
PTFE	Stainless steel	-20 °C (-4 °F)	60 °C (140 °F)	-25 °C (-13 °F)	85 °C (185 °F)
		-20 °C (-4 °F)	30 °C (86 °F)	-25 °C (-13 °F)	130 °C (266 °F)
PFA	Steel	-10 °C (14 °F)	60 °C (140 °F)	-10 °C (14 °F)	85 °C (185 °F)
		-10 °C (14 °F)	30 °C (86 °F)	-10 °C (14 °F)	130 °C (266 °F)
PFA	Stainless steel	-20 °C (-4 °F)	60 °C (140 °F)	-25 °C (-13 °F)	85 °C (185 °F)
		-20 °C (-4 °F)	30 °C (86 °F)	-25 °C (-13 °F)	130 °C (266 °F)
ETFE	Steel	-10 °C (14 °F)	60 °C (140 °F)	-10 °C (14 °F)	85 °C (185 °F)
		-10 °C (14 °F)	30 °C (86 °F)	-10 °C (14 °F)	130 °C (266 °F)
ETFE	Stainless steel	-20 °C (-4 °F)	60 °C (140 °F)	-25 °C (-13 °F)	85 °C (185 °F)
		-20 °C (-4 °F)	30 °C (86 °F)	-25 °C (-13 °F)	130 °C (266 °F)

1) For China production site only.

2) The maximum measuring medium temperature is reduced to 80 °C (176 °F) for design level "B" sensors with a hard rubber liner.

Remote mount design

Liner material	Flange material	Ambient temperature range ($T_{amb.}$)		Measuring medium temperature range (T_{medium})	
		Minimum	Maximum	Minimum	Maximum
Hard rubber	Steel	-10 °C (14 °F)	60 °C (140 °F)	-10 °C (14 °F)	90 °C (194 °F) ²⁾
				-5 °C (23 °F) ¹⁾	80 °C (176 °F) ¹⁾
Hard rubber	Stainless steel	-15 °C (5 °F)	60 °C (140 °F)	-15 °C (5 °F)	90 °C (194 °F) ²⁾
				-5 °C (23 °F) ¹⁾	80 °C (176 °F) ¹⁾
Soft rubber	Steel	-10 °C (14 °F)	60 °C (140 °F)	-10 °C (14 °F)	60 °C (140 °F)
Soft rubber	Stainless steel	-15 °C (5 °F)	60 °C (140 °F)	-15 °C (5 °F)	60 °C (140 °F)
PTFE	Steel	-10 °C (14 °F)	60 °C (140 °F)	-10 °C (14 °F)	130 °C (266 °F)
PTFE	Stainless steel	-25 °C (-13 °F)	60 °C (140 °F)	-25 °C (-13 °F)	130 °C (266 °F)
PFA	Steel	-10 °C (14 °F)	60 °C (140 °F)	-10 °C (14 °F)	130 °C (266 °F)
PFA	Stainless steel	-25 °C (-13 °F)	60 °C (140 °F)	-25 °C (-13 °F)	130 °C (266 °F)
ETFE	Steel	-10 °C (14 °F)	60 °C (140 °F)	-10 °C (14 °F)	130 °C (266 °F)
ETFE	Stainless steel	-25 °C (-13 °F)	60 °C (140 °F)	-25 °C (-13 °F)	130 °C (266 °F)

1) For China production site only.

2) The maximum measuring medium temperature is reduced to 80 °C (176 °F) for design level "B" sensors with a hard rubber liner.

ProcessMaster FEP610

Electromagnetic flowmeter

Measuring range table

The flow range end value can be set between $0.02 \times Q_{\max}DN$ and $2 \times Q_{\max}DN$.

Nominal diameter		Minimum flow range end value	$Q_{\max}DN$	Maximum flow range end value
DN	inch	$0.02 \times Q_{\max}DN (\approx 0.2 \text{ m/s})$	$0 \dots \approx 10 \text{ m/s}$	$2 \times Q_{\max}DN (\approx 20 \text{ m/s})$
3	1/10	0.08 l/min (0.02 US gal/min)	4 l/min (1.06 US gal/min)	8 l/min (2.11 US gal/min)
4	5/32	0.16 l/min (0.04 US gal/min)	8 l/min (2.11 US gal/min)	16 l/min (4.23 US gal/min)
6	1/4	0.4 l/min (0.11 US gal/min)	20 l/min (5.28 US gal/min)	40 l/min (10.57 US gal/min)
8	5/16	0.6 l/min (0.16 US gal/min)	30 l/min (7.93 US gal/min)	60 l/min (15.85 US gal/min)
10	3/8	0.9 l/min (0.24 US gal/min)	45 l/min (11.9 US gal/min)	90 l/min (23.78 US gal/min)
15	1/2	2 l/min (0.53 US gal/min)	100 l/min (26.4 US gal/min)	200 l/min (52.8 US gal/min)
20	3/4	3 l/min (0.79 US gal/min)	150 l/min (39.6 US gal/min)	300 l/min (79.3 US gal/min)
25	1	4 l/min (1.06 US gal/min)	200 l/min (52.8 US gal/min)	400 l/min (106 US gal/min)
32	1 1/4	8 l/min (2.11 US gal/min)	400 l/min (106 US gal/min)	800 l/min (211 US gal/min)
40	1 1/2	12 l/min (3.17 US gal/min)	600 l/min (159 US gal/min)	1200 l/min (317 US gal/min)
50	2	1.2 m ³ /h (5.28 US gal/min)	60 m ³ /h (264 US gal/min)	120 m ³ /h (528 US gal/min)
65	2 1/2	2.4 m ³ /h (10.57 US gal/min)	120 m ³ /h (528 US gal/min)	240 m ³ /h (1057 US gal/min)
80	3	3.6 m ³ /h (15.9 US gal/min)	180 m ³ /h (793 US gal/min)	360 m ³ /h (1585 US gal/min)
100	4	4.8 m ³ /h (21.1 US gal/min)	240 m ³ /h (1057 US gal/min)	480 m ³ /h (2113 US gal/min)
125	5	8.4 m ³ /h (37 US gal/min)	420 m ³ /h (1849 US gal/min)	840 m ³ /h (3698 US gal/min)
150	6	12 m ³ /h (52.8 US gal/min)	600 m ³ /h (2642 US gal/min)	1200 m ³ /h (5283 US gal/min)
200	8	21.6 m ³ /h (95.1 US gal/min)	1080 m ³ /h (4755 US gal/min)	2160 m ³ /h (9510 US gal/min)
250	10	36 m ³ /h (159 US gal/min)	1800 m ³ /h (7925 US gal/min)	3600 m ³ /h (15850 US gal/min)
300	12	48 m ³ /h (211 US gal/min)	2400 m ³ /h (10567 US gal/min)	4800 m ³ /h (21134 US gal/min)
350	14	66 m ³ /h (291 US gal/min)	3300 m ³ /h (14529 US gal/min)	6600 m ³ /h (29059 US gal/min)
400	16	90 m ³ /h (396 US gal/min)	4500 m ³ /h (19813 US gal/min)	9000 m ³ /h (39626 US gal/min)
450	18	120 m ³ /h (528 US gal/min)	6000 m ³ /h (26417 US gal/min)	12000 m ³ /h (52834 US gal/min)
500	20	132 m ³ /h (581 US gal/min)	6600 m ³ /h (29059 US gal/min)	13200 m ³ /h (58117 US gal/min)
600	24	192 m ³ /h (845 US gal/min)	9600 m ³ /h (42268 US gal/min)	19200 m ³ /h (84535 US gal/min)
700	28	264 m ³ /h (1162 US gal/min)	13200 m ³ /h (58118 US gal/min)	26400 m ³ /h (116236 US gal/min)
760	30	312 m ³ /h (1374 US gal/min)	15600 m ³ /h (68685 US gal/min)	31200 m ³ /h (137369 US gal/min)
800	32	360 m ³ /h (1585 US gal/min)	18000 m ³ /h (79252 US gal/min)	36000 m ³ /h (158503 US gal/min)
900	36	480 m ³ /h (2113 US gal/min)	24000 m ³ /h (105669 US gal/min)	48000 m ³ /h (211337 US gal/min)
1000	40	540 m ³ /h (2378 US gal/min)	27000 m ³ /h (118877 US gal/min)	54000 m ³ /h (237754 US gal/min)
1050	42	616 m ³ /h (2712 US gal/min)	30800 m ³ /h (135608 US gal/min)	61600 m ³ /h (271217 US gal/min)
1100	44	660 m ³ /h (3038 US gal/min)	33000 m ³ /h (151899 US gal/min)	66000 m ³ /h (290589 US gal/min)
1200	48	840 m ³ /h (3698 US gal/min)	42000 m ³ /h (184920 US gal/min)	84000 m ³ /h (369841 US gal/min)
1400	54	1080 m ³ /h (4755 US gal/min)	54000 m ³ /h (237755 US gal/min)	108000 m ³ /h (475510 US gal/min)
1500	60	1260 m ³ /h (5548 US gal/min)	63000 m ³ /h (277381 US gal/min)	126000 m ³ /h (554761 US gal/min)
1600	66	1440 m ³ /h (6340 US gal/min)	72000 m ³ /h (317006 US gal/min)	144000 m ³ /h (634013 US gal/min)
1800	72	1800 m ³ /h (7925 US gal/min)	90000 m ³ /h (396258 US gal/min)	180000 m ³ /h (792516 US gal/min)
2000	80	2280 m ³ /h (10039 US gal/min)	114000 m ³ /h (501927 US gal/min)	228000 m ³ /h (1003853 US gal/min)

Process connections

For an overview of the available process connection variants, see the chapter entitled "Overview – models" on page 3.

Installation length

The flange devices comply with the installation lengths specified in ISO 13359, or according to DVGW (process sheet W420, design WP, ISO 4064 short).

For further details, refer to chapter "Dimensions" on page 17.

Materials

Wetted parts		
Part	Standard	Option
Liner material	PTFE, PFA, ETFE, hard rubber, soft rubber	—
Measurement and grounding electrode for liner material		
— Hard rubber	SST 1.4571 (AISI 316Ti)	Hastelloy B-3 (2.4600), Hastelloy C-4 (2.4610), titanium, tantalum, platinum-iridium, SST 1.4539 (AISI 904L)
— Soft rubber		SST 1.4571 (AISI 316Ti), Hastelloy B-3 (2.4600), Hastelloy C-4 (2.4610), Titanium, tantalum, platinum-iridium
— PTFE, PFA, ETFE	SST 1.4539 (AISI 904L)	SST 1.4571 (AISI 316Ti), Hastelloy B-3 (2.4600), Hastelloy C-4 (2.4610), Titanium, tantalum, platinum-iridium
Grounding ring	Stainless steel	On request
Protection plate	Stainless steel	On request

Non-wetted parts (process connection)

DN	Standard	Option
Design level "A" sensor		
DN 3 ... 15 (1/10 ... 1/2")	Stainless steel ¹⁾	—
DN 20 ... 400 (3/4 ... 16")	Steel (galvanized) ²⁾	Stainless steel ¹⁾
DN 450 ... 2000 (18 ... 80")	Steel (painted) ²⁾	—
Design level "B" sensor		
DN 25 ... 600 (1 ... 24")	Steel (painted) ²⁾ Cast Iron (painted) ³⁾	—

The process connections are made of one of the materials listed below:

- 1) 1.4301 (AISI 304), 1.4307, 1.4404 (AISI 316L) 1.4435 (AISI 316L), 1.4541 (AISI 321) 1.4571 (AISI 316Ti)
- 2) 1.0038, 1.0460, 1.0570, 1.0432, ASTM A105, Q255A, 20#, 16Mn
- 3) EN-JS1025 (5.3103)

Sensor housing

Part / DN	Material
Design level "A" sensor	
Housing	
DN 3 ... 400 (1/10 ... 16")	Cast aluminum (painted) Paint coat: ≥ 80 µm thick, RAL 9002
DN 450 ... 2000 (18 ... 80")	Welded steel design (painted) Paint coat: ≥ 80 µm thick, RAL 9002
Meter tube	Stainless steel ⁴⁾
Terminal box	Plastic, gray white, RAL 9002
Cable gland⁵⁾	Polyamide
Design level "B" sensor	
Housing / meter tube	
DN 25 ... 600 (1 ... 24")	Steel (painted), cast Iron (painted) ³⁾ Paint coat: ≥ 80 µm thick, RAL 9002
Terminal box	Plastic, gray white, RAL 9002
Cable gland⁵⁾	Polyamide

The meter tube is made of one of the materials listed below:

- 3) EN-JS1025 (5.3103)
- 4) 1.4301, 1.4307, 1.4404, 1.4435, 1.4541, 1.4571
ASTM materials:
Grade TP304, TP304L, TP316L, TP321, TP316Ti, TP317L, 0Cr18Ni9, 00Cr18Ni10, 0Cr17Ni14Mo2, 0Cr27Ni12Mo3, 0Cr18Ni10Ti
- 5) Cable gland with M 20 x 1.5 or NPT thread, to be selected via the order number.

ProcessMaster FEP610

Electromagnetic flowmeter

Material loads for process connections

The limits for the permissible measuring medium temperature (T_{medium}) and permissible pressure (P_{medium}) are calculated on the basis of the lining and flange material used in the device (refer to the name plate on the device).

Minimum permissible operating pressure

The following tables show the minimum permissible operating pressure (P_{medium}) depending on measuring medium temperature (T_{medium}) and the liner material.

Design level "A" sensor

Liner material	Nominal diameter	P_{medium} [mbar abs]	$T_{\text{medium}}^{1)}$
Hard rubber	DN 15 ... 2000 (1/2 ... 80")	0	< 85 °C (185 °F) < 80 °C (176 °F) ²⁾
Soft rubber	DN 50 ... 2000 (2 ... 80")	0	< 60 °C (140 °F)
PTFE	DN 10 ... 600 (3/8 ... 24")	270	< 20 °C (68 °F)
		400	< 100 °C (212 °F)
		500	< 130 °C (266 °F)
PFA	DN 3 ... 200 (1/10 ... 8")	0	< 130 °C (266 °F)
ETFE	DN 25 ... 600 (1 ... 24")	100	< 130 °C (266 °F)

Design level "B" sensor

Liner material	Nominal diameter	P_{medium} [mbar abs]	$T_{\text{medium}}^{1)}$
Hard rubber	DN 40 ... 600 (1 1/2 ... 24")	600	< 80 °C (176 °F)
PTFE	DN 25 ... 600 (1 ... 24")	270	< 20 °C (68 °F)
		400	< 100 °C (212 °F)
		500	< 130 °C (266 °F)

- For CIP/SIP cleaning, higher temperatures are permitted for limited time periods; refer to the chapter "Maximum permissible cleaning temperature" on page 6.
- For China production site only.

Liner approvals on request; please contact ABB.

Material load

Flowmeter sensor design level "A"

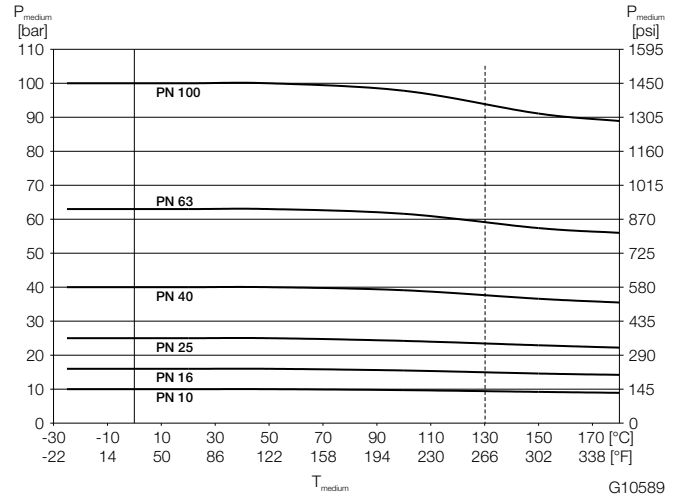

Fig. 4: DIN flange stainless steel up to DN 600 (24")

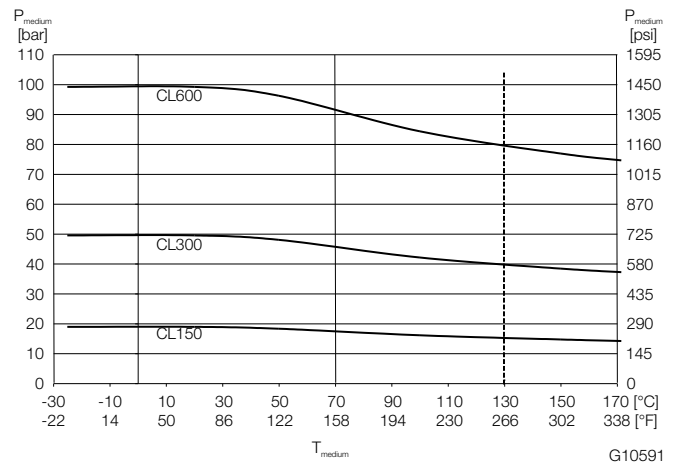

Fig. 5: ASME flange, stainless steel, up to DN 400 (16") (CL150/300) up to DN 1000 (40") (CL150)

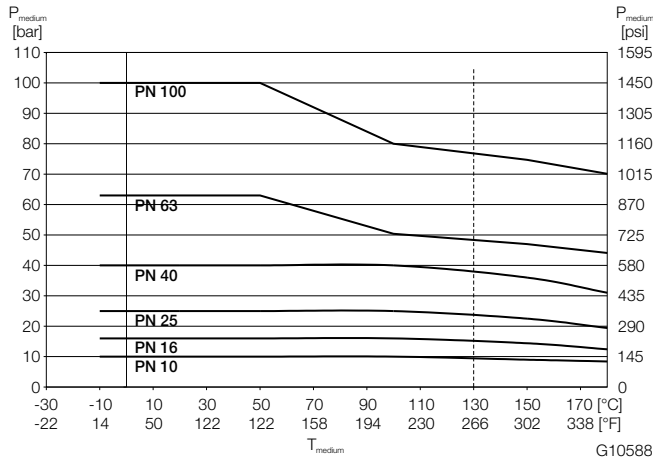

Fig. 6: DIN flange, steel, up to DN 600 (24")

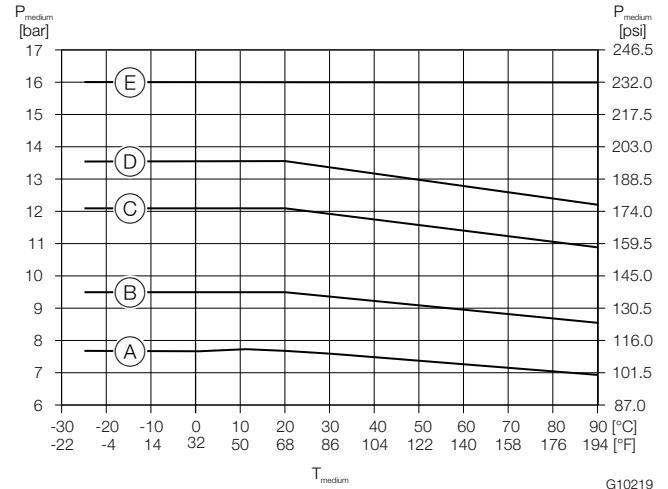

Fig. 8: DIN flange, stainless steel, DN 700 (28") up to DN 1000 (40")
 (A) DN 1000, PN 10 (B) DN 700, DN800, DN900, PN 10 (C) DN 1000, PN 16 (D) DN 900, DN 800, PN 16 (E) DN 700, PN 16

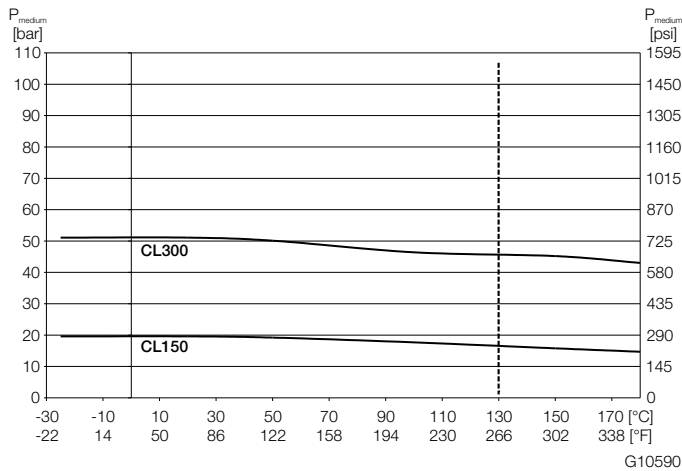

Fig. 7: ASME flange, steel, up to DN 400 (16") (CL150/300); up to DN 1000 (40") (CL150)

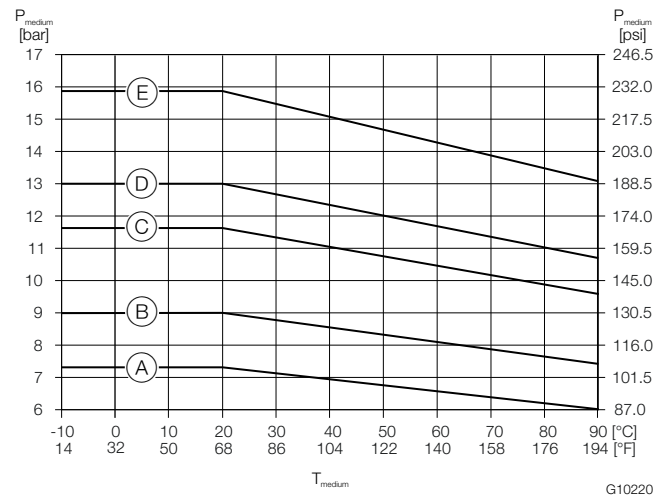

Fig. 9: DIN flange, steel, DN 700 (28") up to DN 1000 (40")
 (A) DN 1000, PN 10 (B) DN 700, DN800, DN900, PN 10 (C) DN 1000, PN 16 (D) DN 900, DN 800, PN 16 (E) DN 700, PN 16

JIS 10K-B2210 flange

DN	Material	PN	T_{medium}	P_{medium}
DN 32 ... 400 (1 1/4 ... 16")	Stainless steel	10	-25 ... 180 °C (-13 ... 356 °F)	10 bar (145 psi)
DN 32 ... 400 (1 1/4 ... 16")	Steel	10	-10 ... 180 °C (14 ... 356 °F)	10 bar (145 psi)

ProcessMaster FEP610 Electromagnetic flowmeter

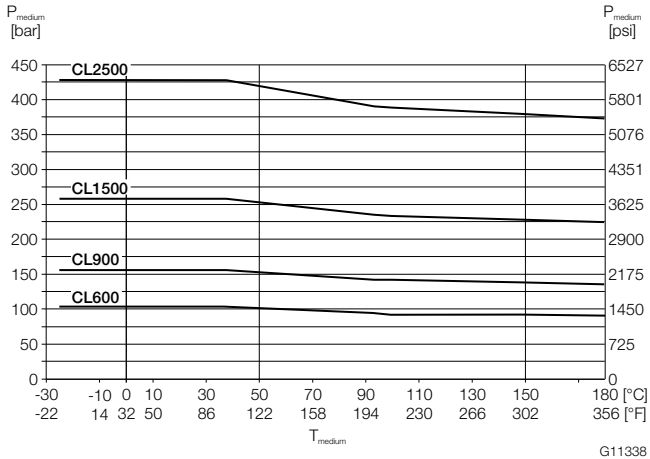

Fig. 10: ASME flange, Steel, DN 25 ... 400 (1 ... 24“)

Flowmeter sensor design level “B”

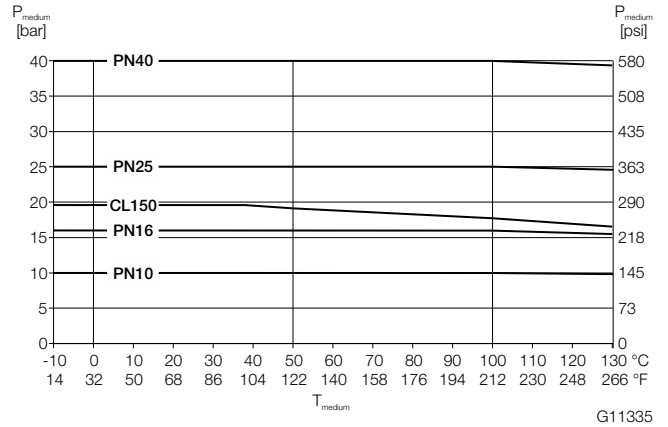

Fig. 12: Cast iron housing, DN 25 ... 600 (1 ... 24“)

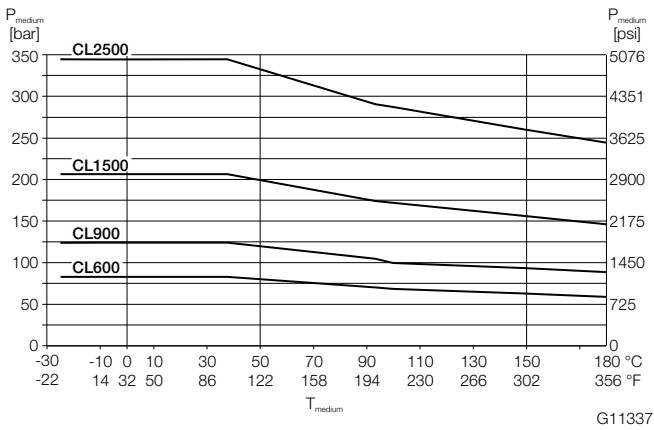

Fig. 11: ASME flange, stainless steel, DN 25 ... 400 (1 ... 24“)

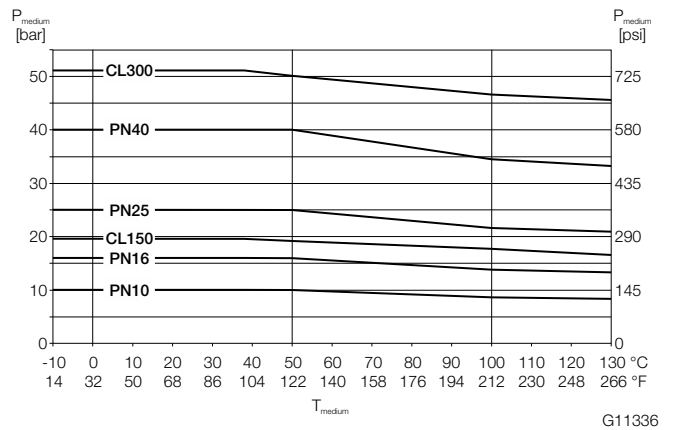

Fig. 13: Welded steel housing, DN 25 ... 600 (1 ... 24“)

Installation conditions

General information

The following points must be observed during installation:

- The flow direction must correspond to the marking, if present.
- The maximum torque for all flange screws must be complied with.
- Secure the flange bolts and nuts against pipe vibration.
- The devices must be installed without mechanical tension (torsion, bending).
- Install flange devices / wafer-type devices with plane parallel counterflanges and use appropriate gaskets only.
- Only gaskets made from a material that is compatible with the measuring medium and measuring medium temperature may be used.
- Gaskets must not extend into the flow area, since possible turbulence could influence the accuracy of the device.
- The piping may not exert any inadmissible forces or torques on the device.
- Make sure temperature limits are not exceeded operating the device.
- Vacuum shocks in the piping should be avoided to prevent damage to the liners (PTFE). Vacuum shocks can destroy the device.
- Do not remove the sealing plugs in the cable glands until you are ready to install the electrical cable.
- Make sure the gaskets for the housing cover are seated correctly. Carefully gasket the cover. Tighten the cover fittings.
- The transmitter with a remote mount design must be installed at a largely vibration-free location.
- Do not expose the transmitter and sensor to direct sunlight. Provide appropriate sun protection as necessary.
- When installing the transmitter in a control cabinet, make sure adequate cooling is provided.
- In case of a remote mounted transmitter make sure that the sensor and the transmitter have been assigned correctly. Compatible devices have the same end numbers on the name plate, e.g. flowmeter sensor X001 belongs to transmitter Y001 or flowmeter sensor X002 belongs to transmitter Y002.

Brackets and supports

NOTE - Potential damage to device!

Improper support for the device may result in deformed housing and damage to internal magnet coils.

Place the supports at the edge of the flowmeter sensor housing (see arrows in Fig. 14).

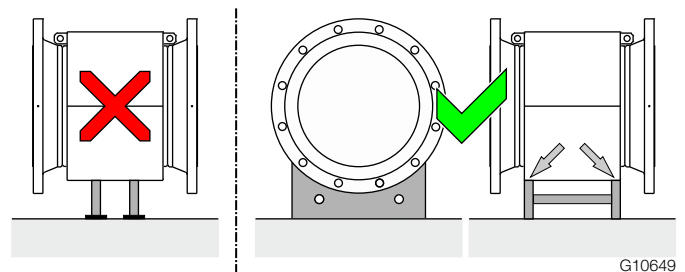

Fig. 14: Support for meter sizes larger than DN 400

Devices with meter sizes larger than DN 400 must be mounted with support on a sufficiently strong foundation.

Gaskets

The following points must be observed when installing gaskets:

- For achieve the best results, ensure the gaskets fit concentrically with the meter tube
- To ensure that the flow profile is not distorted, the gaskets must not protrude into the piping.
- The use of graphite with the flange or process connection gaskets is prohibited, because an electrically conductive coating may form on the inside of the meter tube.

Devices with a hard rubber, soft rubber liner

- Devices with a hard / soft rubber liner always require additional gaskets.
- ABB recommends using gaskets made from rubber or rubber-like sealing materials.
- When selecting the gaskets, ensure that the tightening torques specified in chapter "Torque information" in the operating instruction are not exceeded.

Devices with a PTFE, PFA or ETFE liner

- In principle, devices with a PTFE, PFA or ETFE liner do not require additional gaskets.

ProcessMaster FEP610 Electromagnetic flowmeter

Flow direction

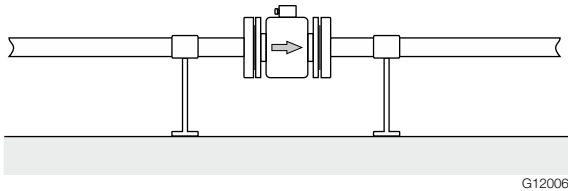

G12006

Fig. 15: Flow direction

The device measures the flowrate in both directions. Forward flow is the factory setting, as shown in Fig. 15.

Elektrode axis

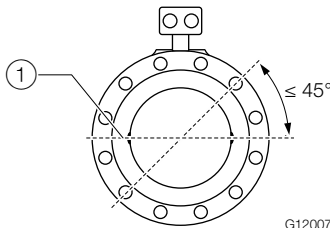

G12007

Fig. 16: Orientation of the electrode axis

① Elektrode axis

The electrode axis should be horizontal if at all possible or no more than 45° from horizontal.

Mounting position

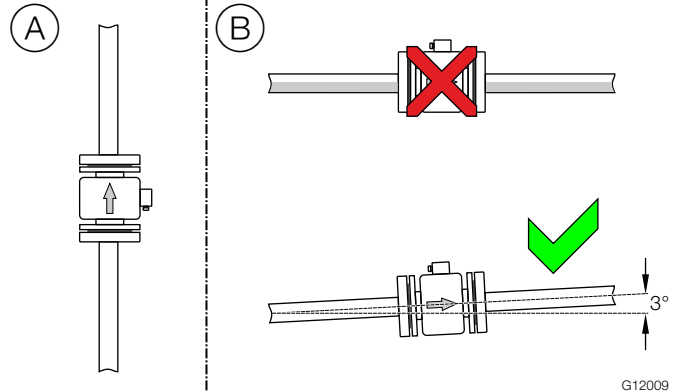

G12009

Fig. 17: Mounting position

- Ⓐ Vertical installation for measuring abrasive fluids, preferably with flow in upward direction.
- Ⓑ In case of horizontal installation, the Meter tube must always be completely full. Provide for a slight incline of the connection for degassing.

Minimum distance

ProcessMaster FEPxxx

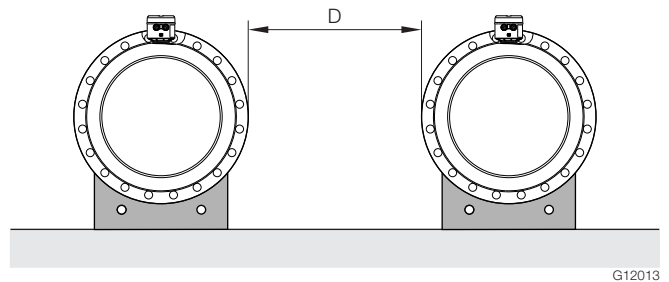

G12013

Distance D: ≥ 1.0 m (3.3 ft) for design level "A", ≥ 0.7 m (2.3 ft) for design level "B"

Fig. 18: Minimum distance

- In order to prevent the devices from interfering with each other, a minimum distance as shown in Fig. 18 must be maintained between the devices.
- The flowmeter sensor may not be operated in the vicinity of powerful electromagnetic fields, e.g., motors, pumps, transformers, etc. A minimum spacing of approx. 1 m (3.28 ft) should be maintained.
- For installation on or to steel parts (e.g. steel brackets), a minimum spacing of approx. 100 mm (3.94 inch) should be maintained (based on IEC801-2 and IECTC77B).

Inlet and outlet sections

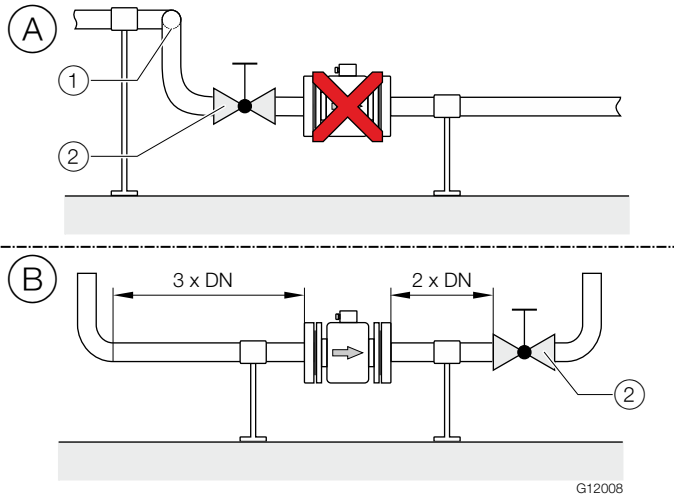

Fig. 19: In- and outlet section, turn-off component
 ① Double elbow ② Turn-off component

The metering principle is independent of the flow profile as long as standing eddies do not extend into the metering section, such as may occur after double elbows, in the event of tangential inflow, or where half-open gate valves are located upstream of the flowmeter sensor.

In such cases, measures must be put in place to normalize the flow profile.

- Ⓐ Do not install fittings, manifolds, valves, etc., directly in front of the flowmeter sensor.
- Ⓑ Inlet and outlet section: Length of straight inlet and outlet section of the flowmeter sensor.
 Experience has shown that, in most installations, inlet sections 3 x DN long and outlet sections 2 x DN long are sufficient (DN = nominal diameter of the flowmeter sensor). For test stands, the reference conditions of 10 x DN inlet section and 5 x DN outlet section must be provided, in accordance with EN 29104 / ISO 9104.
 Valves or other turn-off components should be installed in the outlet section.
 Butterfly valves must be installed so that the valve plate does not extend into the flowmeter sensor.

Free inlet or outlet

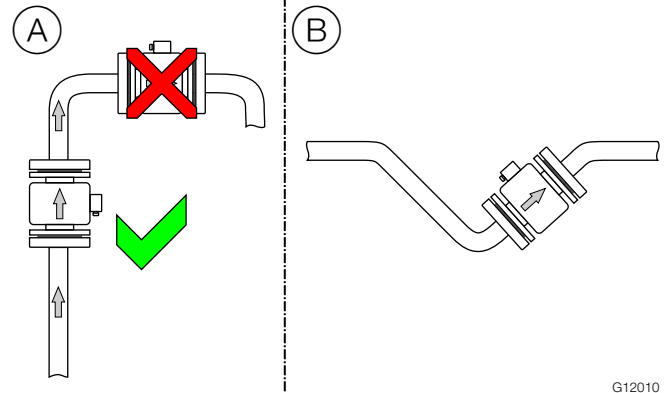

Fig. 20: Free inlet or outlet

- Ⓐ Do not install the flowmeter at the highest point or in the draining off side of the pipeline, flowmeter runs empty, air bubbles can form.
- Ⓑ Provide for a siphon fluid intake for free inlets or outlets so that the pipeline is always full.

Strongly contaminated measuring media

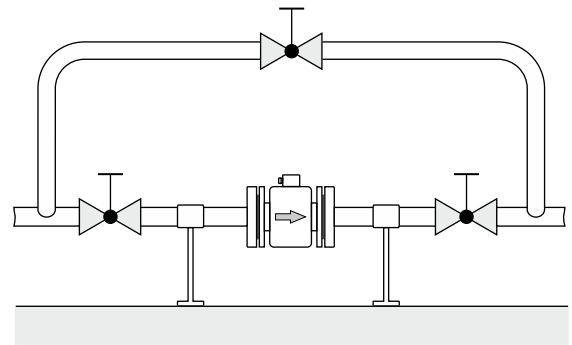

Fig. 21: Bypass connection

For strongly contaminated measuring media, a bypass connection according to the figure is recommended so that operation of the system can continue to run without interruption during the mechanical cleaning.

ProcessMaster FEP610 Electromagnetic flowmeter

Installation in the vicinity of pumps

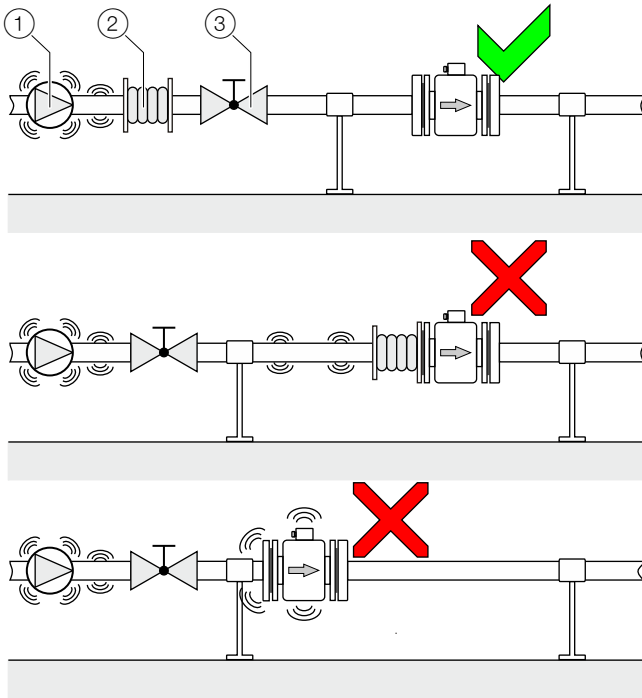

Fig. 22: Vibration damping

① Pump ② Damping device ③ Shut-off device

Strong vibrations in the pipeline must be damped using flexible damping devices.

The damping devices must be installed beyond the supported flowmeter section and outside of the section between the shut-off devices.

Do not connect flexible damping devices directly to the flowmeter sensor.

Installation in pipelines with larger nominal diameters

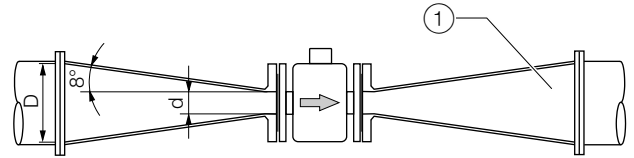

G12014

Fig. 23: using reduction pieces

① Transition piece

Determine the resulting pressure loss when using transition pieces:

1. Calculate the diameter ratio d/D .
2. Determine the flow velocity based on the flow range nomograph (Fig. 24).
3. Read the pressure drop on the Y-axis in Fig. 24.

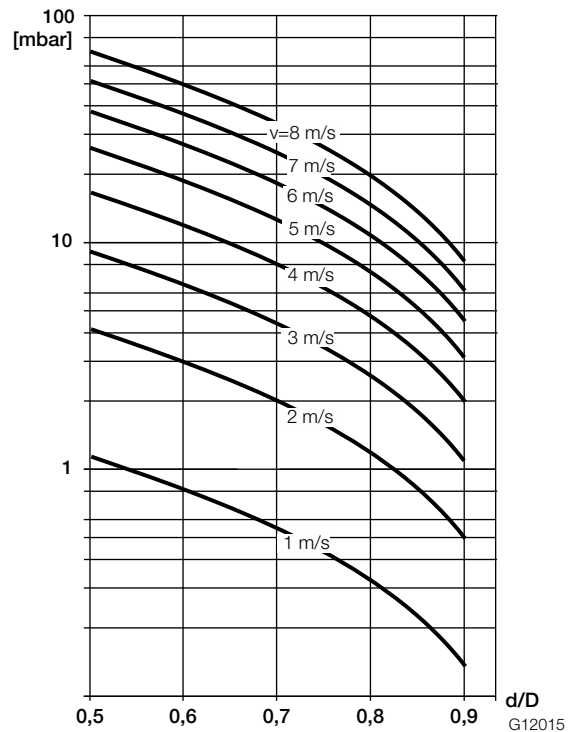
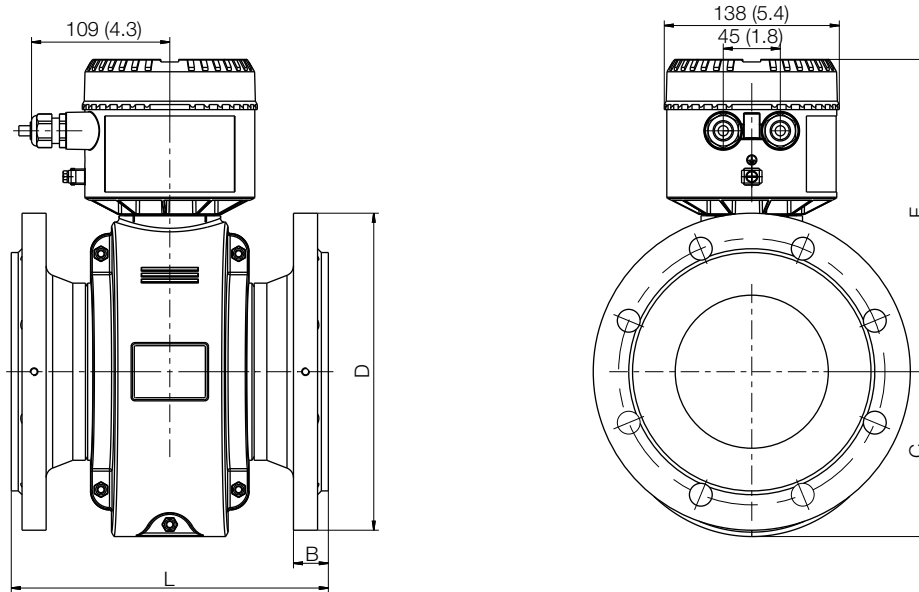

Fig. 24: Nomograph for pressure drop calculations for flange transition piece with $\alpha/2 = 8^\circ$

Dimensions

Flange DN 3 ... 100 (1/10 ... 4"), aluminum sensor housing (shell housing) – Design level "A"

All specified dimensions and weights are in mm (inch) or kg (lb).



G12042

Fig. 25

Dimensions - Flange device, aluminum sensor housing (shell housing) – Design level "A"							Approx. weight	
Nominal diameter	Process connection	D	B	L ^(2) 3)	C	F	Remote	Integral
DN 3 ... 8 ⁴⁾ (1/8 ... 5/16" ⁵⁾)	EN 1092-1 ⁶⁾ , PN 10 ... 40 ¹⁾	90 (3.54)	19 (0.75)	200 (7.84)	82 (3.23)	191 (7.52)	4.5 (10)	5.5 (12)
DN 10 (3/8" ⁵⁾)	ASME B16.5, CL 150	90 (3.54)	14.2 (0.56)					
	ASME B16.5, CL 300	95 (3.74)	17.3 (0.68)					
DN 15 (1/2")	JIS 10K	90 (3.54)	15 (0.59)	200 (7.84)	82 (3.23)	191 (7.52)	4.5 (10)	5.5 (12)
	EN 1092-1 ⁶⁾ , PN 10 ... 40 ¹⁾	95 (3.74)	19 (0.75)					
	ASME B16.5, CL 150	90 (3.54)	14.2 (0.56)					
	ASME B16.5, CL 300	95.2 (3.75)	17.3 (0.68)					
DN 20 (3/4")	JIS 10K	95 (3.74)	15 (0.59)	200 (7.84)	82 (3.23)	191 (7.52)	6 (13)	6.5 (14)
	EN 1092-1 ⁶⁾ , PN 10 ... 40 ¹⁾	105 (4.13)	21 (0.83)					
	ASME B16.5, CL 150	98.6 (3.88)	15.7 (0.62)					
	ASME B16.5, CL 300	117.3 (4.62)	18.7 (0.74)					
	JIS 10K	100 (3.94)	17 (0.67)					

Tolerance for L: +0 / -3 mm (+0 / -0.018 inch)

ProcessMaster FEP610

Electromagnetic flowmeter

Dimensions - Flange device, aluminum sensor housing (shell housing) – Design level "A"							Approx. weight	
Nominal diameter	Process connection	D	B	L ^(2) 3)	C	F	Remote	Integral
DN 25 (1")	EN 1092-1 ⁶⁾ , PN 10 ... 40 ¹⁾	115 (4.53)	21 (0.83)	200 (7.84)	82 (3.23)	191 (7.52)	7 (15)	7.5 (16.5)
	ASME B16.5, CL 150	108 (4.25)	17.2 (0.68)					
	ASME B16.5, CL 300	124 (4.88)	20.5 (0.81)					
	JIS 10K	125 (4.92)	17 (0.67)					
DN 32 (1 1/4")	EN 1092-1 ⁶⁾ , PN 10 ... 40 ¹⁾	140 (5.51)	21 (0.83)	200 (7.84)	92 (3.62)	198 (7.80)	8 (17.5)	8.5 (18.5)
	ASME B16.5, CL 150	117.3 (4.62)	18.7 (0.74)					
	ASME B16.5, CL 300	133.4 (5.25)	22.1 (0.87)					
	JIS 10K	135 (5.31)	19 (0.75)					
DN 40 (1 1/2")	EN 1092-1 ⁶⁾ , PN 10 ... 40 ¹⁾	150 (5.91)	21 (0.83)	200 (7.84)	92 (3.62)	198 (7.80)	9 (20)	9.5 (21)
	ASME B16.5, CL 150	127 (5.00)	20.5 (0.81)					
	ASME B16.5, CL 300	155.4 (6.12)	23.6 (0.93)					
	JIS 10K	140 (5.51)	19 (0.75)					
DN 50 (2")	EN 1092-1 ⁶⁾ , PN 10 ... 40 ¹⁾	165 (6.50)	23 (0.91)	200 (7.87)	97.5 (3.84)	204 (8.0)	10 (22)	11 (24)
	ASME B16.5, CL 150	152.4 (6.00)	22.1 (0.87)					
	ASME B16.5, CL 300	165.1 (6.50)	25.4 (1.0)					
	JIS 10K	155 (6.10)	19 (0.75)					
	AS2129 table D, E	150 (5.91)	–				8 (17.5)	8.5 (18.5)
DN 65 (2 1/2")	EN 1092-1 ⁶⁾ , PN 16 ¹⁾	185 (7.28)	22 (0.87)	200 (7.87)	108.5 (4.25)	215 (8.46)	11 (24)	11,5 (25)
	EN 1092-1 ⁶⁾ , PN 40 ¹⁾	185 (7.28)	26 (1.02)				13 (28.5)	13,5 (30)
	ASME B16.5, CL 150	177.8 (7.00)	25.4 (1.0)				11 (24)	11,5 (25)
	ASME B16.5, CL 300	190.5 (7.50)	28.4 (1.12)				13 (28.5)	13,5 (30)
	JIS 10K	175 (6.89)	21 (0.83)				13 (28.5)	13,5 (30)
	AS2129 table D, E	165 (6.50)	–				–	–
DN 80 (3")	EN 1092-1 ⁶⁾ , N 10 ... 40 ¹⁾	200 (7.87)	28 (1.10)	200 (7.87)	108.5 (4.27)	215 (8.46)	15 (33)	15,5 (34)
	ASME B16.5, CL 150	190.5 (7.50)	26.9 (1.06)				15 (33)	15,5 (34)
	ASME B16.5, CL 300	210 (8.27)	31.4 (1.24)				17 (37.5)	17,5 (38.5)
	JIS 10K	185 (7.28)	21 (0.83)				17 (37.5)	17,5 (38.5)
	AS2129 table D, E	185 (7.28)	–				–	–

Tolerance for L: +0 / -3 mm (+0 / -0.018 inch)

Dimensions - Flange device, aluminum sensor housing (shell housing) – Design level "A"							Approx. weight	
Nominal diameter	Process connection	D	B	L ^{2) 3)}	F	C	Remote	Integral
DN 100 (4")	EN 1092-1 ⁶⁾ PN 16 ¹⁾	220 (8.66)	24 (0.94)	250 (9.84)	122.5 (4.82)	237 (9.33)	17 (37.5)	17,5 (38.5)
	EN 1092-1 ⁶⁾ PN 25 ... 40 ¹⁾	235 (9.25)	28 (1.10)				21 (46)	21,5 (47)
	ASME B16.5 CL 150	228.6 (9.00)	27.4 (1.08)				19 (42)	19,5 (43)
	ASME B16.5 CL 300	254 (10.0)	35.8 (1.41)				28 (62)	28,5 (63)
	JIS 10K	210 (8.72)	21 (0.83)				17 (37.5)	17,5 (38.5)
	AS2129 table D, E	215 (8.46)	—				—	—

Tolerance for L: +0 / -3 mm (+0 / -0.018 inch)

- 1) Other pressure ratings on request.
- 2) If a grounding ring is fitted (attached to one side of the flange), dimension L increases as follows: by 3 mm (0.118 inch) for DN 3 ... 100, and by 5 mm (0.197 inch) for DN 125.
- 3) If protection plates are fitted (attached to both sides of the flange), dimension L increases as follows: by 6 mm (0.236 inch) for DN 3 ... 100, and by 10 mm (0.394 inch) for DN 125.
- 4) Connection flange DN 10.
- 5) Connection flange 1/2".
- 6) Connecting dimensions in accordance with EN 1092-1. For DN 65, PN 16 in accordance with EN 1092-1, please order PN 40.

ProcessMaster FEP610 Electromagnetic flowmeter

Flange DN 125 ... 400 (6 ... 16"), aluminum sensor housing (shell housing) – Design level "A"

All specified dimensions and weights are in mm (inch) or kg (lb).

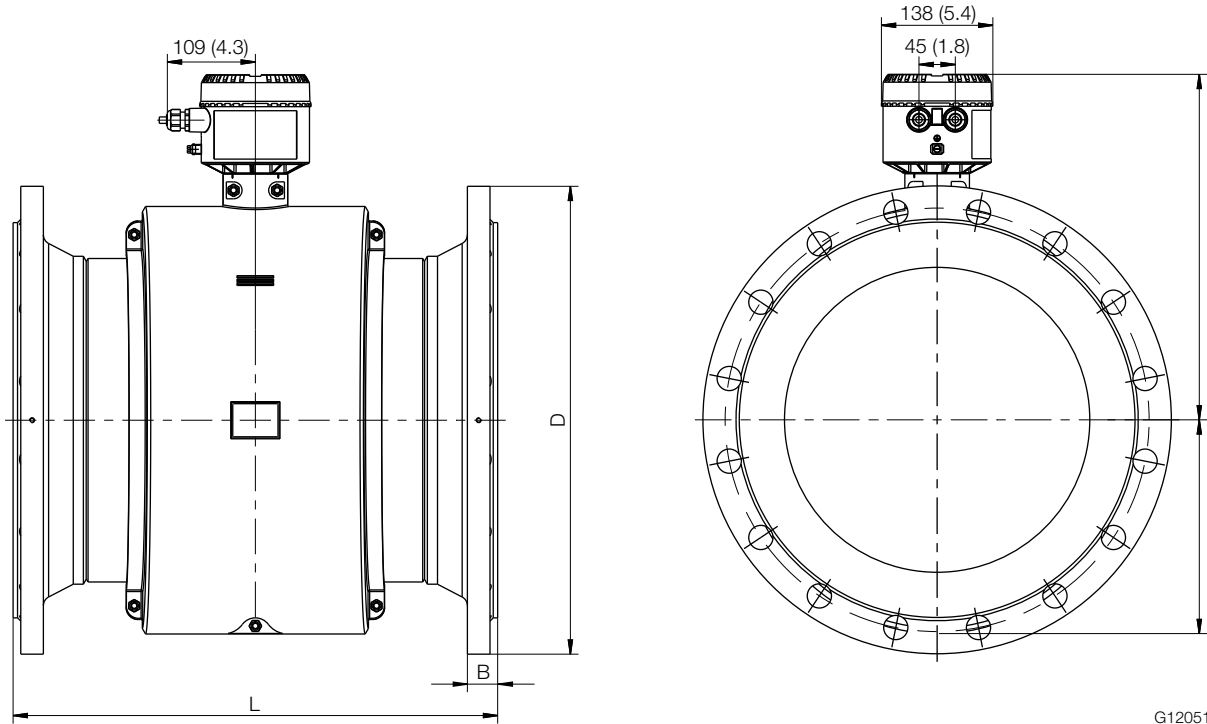

Fig. 26

G12051

Dimensions - Flange device, aluminum sensor housing (shell housing) – Design level "A"							Approx. weight	
Nominal diameter	Process connection	D	B	L ^(2) 3)	C	F	Remote	Integral
DN 125 (5")	EN 1092-1 ⁽⁶⁾ PN 16 ⁽¹⁾	250 (9.84)	25 (0.98)	250 (9.84)	130 (5.12)	247 (9.72)	20 (44)	20,5 (45)
	EN 1092-1 ⁽⁶⁾ PN 25 ... 40 ⁽¹⁾	270 (10.63)	29 (1.14)				27 (59.5)	27,5 (60.5)
	ASME B16.5 CL 150	254 (10.0)	27.9 (1.10)				20 (44)	20,5 (45)
	ASME B16.5 CL 300	279.4 (11.0)	39.1 (1.54)	33 (73)			33,5 (74)	
	JIS 10K	250 (9.84)	27 (1.06)	20 (44)			20,5 (45)	
	AS2129 table D, E	255 (10.04)	—	—			—	
DN 150 (6")	EN 1092-1 PN 16 ⁽¹⁾	285 (11.22)	25 (0.98)	300 (11.81)	146 (5.75)	294 (11.57)	31 (68)	31.5 (69.5)
	EN 1092-1 PN 25 ... 40 ⁽¹⁾	300 (11.81)	31 (1.22)				37 (81.5)	37.5 (82.5)
	ASME B16.5 CL 150	279.4 (11.0)	29.4 (1.16)				31 (68)	31.5 (69.5)
	ASME B16.5 CL 300	317.5 (12.5)	40.5 (1.59)	45 (99)			45.5 (100)	
	JIS 10K	280 (11.02)	28 (1.10)	31 (68)			31.5 (69.5)	
	AS2129 table D, E	280 (11.02)	—	31 (68)			31.5 (69.5)	

Tolerance for L: +0 / -3 mm (+0 / -0.018 inch)

Dimensions - Flange device, aluminum sensor housing (shell housing) – Design level "A"							Approx. weight	
Nominal diameter	Process connection	D	B	L ^(2) 3)	C	F	Remote	Integral
DN 200 (8")	EN 1092-1, PN 10 ... 16 ¹⁾	340 (13.39)	28 (1.10)	350 (13.78)	170.5 (6.71)	334 (13.15)	41 (90)	41.5 (90.5)
	EN 1092-1, PN 25 ¹⁾	360 (14.17)	34 (1.34)				53 (117)	53.5 (118)
	EN 1092-1, PN 40 ¹⁾	375 (14.76)	38 (1.50)				63 (150)	63.5 (151)
	ASME B16.5, CL 150	345 (13.58)	33.6 (1.32)				48 (106)	48.5 (107)
	ASME B16.5, CL 300	380 (14.96)	46.1 (1.81)				70 (154)	70.5 (155.5)
	JIS 10K	330 (12.99)	33 (1.30)				41 (90)	41.5 (90.5)
	AS2129 table D, E	335 (13.19)	—				48 (106)	48.5 (107)
DN 250 (10")	EN 1092-1, PN 10 ¹⁾	395 (15.55)	30 (1.18)	450 (17.72)	198 (7.80)	349 (13.74)	59 (130)	59.5 (131)
	EN 1092-1, PN 16 ¹⁾	405 (15.94)	30 (1.18)				63 (139)	63.5 (140)
	EN 1092-1, PN 25 ¹⁾	425 (16.73)	36 (1.42)				82 (181)	82.5 (182)
	EN 1092-1, PN 40 ¹⁾	450 (17.72)	42 (1.65)				93 (205)	93.5 (206)
	ASME B16.5, CL 150	405 (15.94)	35.2 (1.39)				68 (150)	68.5 (151)
	ASME B16.5, CL 300	445 (17.52)	52.8 (2.08)				103 (227)	103.5 (228)
	JIS 10K	400 (15.75)	37 (1.46)				63 (139)	63.5 (140)
	AS2129 table D, E	405 (15.94)	—				68 (150)	68.5 (151)
DN 300 (12")	EN 1092-1, PN 10 ¹⁾	445 (17.52)	31 (1.22)	500 (19.68)	228 (8.98)	372 (14.62)	72 (159)	72.5 (160)
	EN 1092-1, PN 16 ¹⁾	460 (18.11)	33 (1.30)				78 (172)	78.5 (173)
	EN 1092-1, PN 25 ¹⁾	485 (19.09)	39 (1.54)				98 (216)	98.5 (217)
	EN 1092-1, PN 40 ¹⁾	515 (20.28)	47 (1.85)	600 (23.62)			138 (304)	138.5 (305)
	ASME B16.5, CL 150	485 (19.09)	36.8 (1.45)	500 (19.68)			103 (227)	103.5 (228)
	ASME B16.5, CL 300	520 (20.47)	55.8 (2.20)	148 (326)			148.5 (327)	
	JIS 10K	450 (17.72)	40 (1.57)	78 (172)			78.5 (173)	
	AS2129 table D, E	455 (17.19)	—	103 (227)			103.5 (228)	
DN 350 (14")	EN 1092-1, PN 10 ¹⁾	505 (19.88)	31 (1.22)	550 (21.65)	267 (10.51)	416 (16.38)	93 (205)	93.5 (206)
	EN 1092-1, PN 16 ¹⁾	520 (20.47)	35 (1.38)				108 (238)	108.5 (239)
	EN 1092-1, PN 25 ¹⁾	555 (21.85)	43 (1.69)				143 (315)	143.5 (316)
	ASME B16.5, CL 150	535 (21.06)	40.1 (1.58)				128 (282)	128.5 (283)
	ASME B16.5, CL 300	585 (23.03)	58.8 (2.31)				196 (432)	196.5 (433)
	JIS 10K	490 (19.29)	—				108 (238)	108.5 (239)
	AS2129 table D, E	525 (20.67)	—				103 (227)	103.5 (228)
DN 400 (16")	EN 1092-1 PN 10 ¹⁾	565 (22.24)	31 (1.22)	600 (23.62)	267 (10.51)	416 (16.38)	101 (223)	101.5 (224)
	EN 1092-1 PN 16 ¹⁾	580 (22.83)	37 (1.46)				124 (273)	124.5 (274)
	EN 1092-1 PN 25 ¹⁾	620 (24.41)	45 (1.77)				168 (370)	168.5 (371)
	ASME B16.5 CL 150	595 (23.43)	41.6 (1.64)				173 (381)	173.5 (382)
	ASME B16.5 CL 300	650 (25.59)	62.2 (2.45)				263 (580)	262.5 (579)
	JIS 10K	560 (22.05)	—				124 (273)	124.5 (274)
	AS2129 table D, E	580 (22.83)	—				173 (381)	173.5 (382)

Tolerance for L: DN 150 ... 200: +0 / -3 mm (+0 / -0.018 inch), DN 250 ... 400: +0 / -5 mm (+0 / -0.197 inch)

1) Other pressure ratings on request.

2) If a grounding ring is fitted is fitted (attached to one side of the flange) dimension L increases by 5 mm (0.197 inch).

3) If protection plates are fitted (attached to both sides of the flange) dimension L increases by 10 mm (0.394 inch).

ProcessMaster FEP610 Electromagnetic flowmeter

Flange DN 450 ... 2000 (18 ... 80"), steel sensor housing - Design level "A"

All specified dimensions and weights are in mm (inch) or kg (lb).

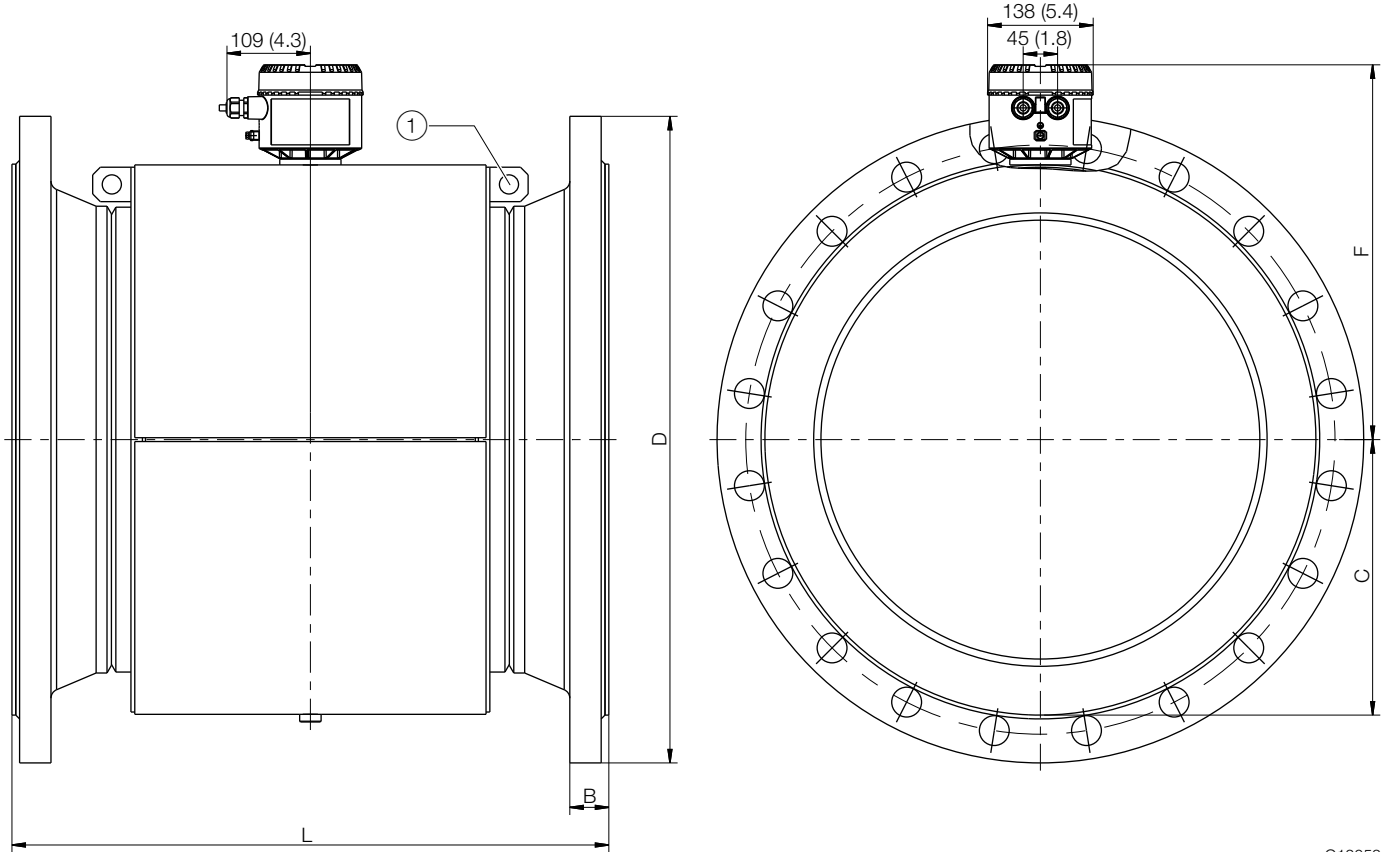

G12052

Fig. 27

① Transport lugs

Dimensions - Flange device, steel sensor housing - Design level "A"							Approx. weight	
Nominal diameter	Process connection	D	B	L ^{(2) (3)}	C	F	Remote	Integral
DN 450 (18")	ASME B16.5, CL 150	635 (25.0)	44.6 (1.76)	686 (27.01)	310 (12.20)	437 (17.20)	258 (569)	258.5 (570)
	AS2129 table D, E	640 (25.20)	—					
DN 500 (20")	EN 1092-1, PN 10 ⁽¹⁾	670 (26.38)	33 (1.30)	650 (25.59)	310 (12.20)	437 (17.20)	188 (415)	188.5 (416)
	EN 1092-1, PN 16 ⁽¹⁾	715 (28.15)	39 (1.54)				238 (525)	238.5 (526)
	ASME B16.5, CL 150	698.5 (27.50)	47.9 (1.89)	762 (30.0)			298 (657)	298.5 (658)
	AS2129 table D, E	705 (27.76)	—	650 (25.59)				
DN 600 (24")	EN 1092-1, PN 10 ⁽¹⁾	780 (30.71)	33 (1.30)	780 (30.71)	361 (14.21)	490 (19.29)	338 (745)	338.5 (746)
	EN 1092-1, PN 16 ⁽¹⁾	840 (33.07)	41 (1.61)				316 (697)	316.5 (698)
	ASME B16.5, CL 150	812.8 (32.0)	52.8 (2.08)	914 (35.98)			423 (933)	423.5 (934)
	AS2129 table D, E	825 (32.48)	—	780 (30.71)				

Tolerance for L: DN 450 ... 500: +0 / -3 mm (+0 / -0.018 inch), DN 600 ... 2000: +0 / -10 mm (+0 / -0.394 inch)

Dimensions - Flange device, steel sensor housing - Design level "A"							Approx. weight	
Nominal diameter	Process connection	D	B	L ^{2) 3)}	C	F	Remote	Integral
DN 700 (28")	EN 1092-1, PN 10 ¹⁾	895 (35.24)	35 (1.38)	910 (35.83)	405 (15.94)	534 (21.02)	318 (701)	318.5 (702)
	EN 1092-1, PN 16 ¹⁾	910 (35.83)	36 (1.42)				438 (966)	438.5 (967)
	ASME B16.47, CL 150	836.7 (32.94)	49.5 (1.95)				348 (767)	348.5 (768)
DN 750 (30")	ASME B16.5, CL 150	888 (34.96)	44.5 (1.75)	990 (38.96)	431 (16.97)	560 (22.05)	474 (1045)	474.5 (1046)
DN 800 (32")	EN 1092-1, PN 10 ¹⁾	1015 (39.96)	37 (1.46)	1040 (40.94)	455 (17.91)	584 (22.99)	418 (922)	418.5 (923)
	EN 1092-1, PN 16 ¹⁾	1025 (40.35)	43 (1.69)				488 (1076)	488.5 (1077)
	ASME B16.47, CL 150	942 (37.09)	51 (2.01)				498 (1098)	498.5 (1099)
DN 900 (36")	EN 1092-1, PN 10 ¹⁾	1115 (43.90)	39 (1.54)	1170 (46.06)	505 (19.88)	635 (25.0)	503 (1109)	503.5 (1110)
	EN 1092-1, PN 16 ¹⁾	1125 (44.29)	45 (1.77)				588 (1296)	588.5 (1297)
	ASME B16.47, CL 150	1157.1 (41.62)	57.3 (2.26)				678 (1495)	678.5 (1496)
DN 1000 (40")	EN 1092-1, PN 10 ¹⁾	1230 (48.43)	39 (1.54)	1300 (51.18)	555 (21.85)	685 (26.97)	688 (1516)	688.5 (1517)
	EN 1092-1, PN 16 ¹⁾	1255 (49.41)	47 (1.85)				848 (1869)	848.5 (1870)
	ASME B16.47, CL 150	1174.8 (46.25)	60.6 (2.39)				878 (1936)	878.5 (1937)
DN 1050 (42")	ASME B16.47, CL 150	1067 (42.01)	58.7 (2.31)	1365 (53.74)	607 (23.90)	737 (29.02)	930 (2050)	930.5 (2051)
DN 1100 (44")	ASME B16.47, CL 150	1118 (44.02)	60.5 (2.38)	1430 (56.30)	607 (23.90)	737 (29.02)	960 (2116)	960.5 (2117)
DN 1200 (48")	EN 1092-1, PN 10 ¹⁾	1455 (57.28)	43 (1.69)	1560 (61.42)	660 (25.98)	791 (31.14)	928 (2046)	928.5 (2047)
	EN 1092-1, PN 16 ¹⁾	1485 (58.46)	53 (2.09)				1118 (2465)	1118.5 (2466)
DN 1400 (56")	EN 1092-1 PN 10 ¹⁾	1675 (65.94)	47 (1.85)	1820 (71.65)	755 (29.72)	885 (34.84)	1208 (2663)	1208.5 (2664)
	EN 1092-1 PN 16 ¹⁾	1685 (66.34)	57 (2.24)				1758 (3876)	1758.5 (3877)
DN 1500 (60")	ASME B16.47, CL 150	1676 (65.98)	76.2 (3.00)	1950 (76.77)	807 (31.77)	937 (36.89)	1950 (4299)	1950.5 (4300)
DN 1600 (64")	EN 1092-1 PN 10 ¹⁾	1915 (75.39)	51 (2.01)	2080 (81.89)	865 (34.06)	996 (39.21)	1628 (3589)	1628.5 (3590)
	EN 1092-1 PN 16 ¹⁾	1930 (75.98)	63 (2.48)				2148 (4736)	2148.5 (4737)
DN 1800 (72")	EN 1092-1 PN 10 ¹⁾	2115 (83.27)	55 (2.17)	2340 (92.13)	980 (38.58)	1111 (43.74)	2228 (4912)	2228.5 (4913)
	EN 1092-1 PN 16 ¹⁾	2130 (83.86)	67 (2.64)				2898 (6389)	2898.5 (6390)
DN 2000 (80")	EN 1092-1 PN 10 ¹⁾	2325 (91.54)	59 (2.32)	2600 (102.36)	1090 (42.91)	1221 (48.07)	1878 (4140)	1878.5 (4141)
	EN 1092-1 PN 16 ¹⁾	2345 (92.32)	71 (2.80)				2648 (5838)	2648.5 (5839)

Tolerance for L: DN 600 ... 2000:+0 / -10 mm (+0 / -0.394 inch)

1) Other pressure ratings on request.

2) If a grounding ring is fitted (attached to one side of the flange) dimension L increases by 5 mm (0.197 inch).

3) If protection plates are fitted (attached to both sides of the flange) dimension L increases by 10 mm (0.394 inch).

ProcessMaster FEP610 Electromagnetic flowmeter

Flange DN 25 ... 125 (1 ... 5"), cast iron sensor housing – Design level "B"

All specified dimensions and weights are in mm (inch) or kg (lb).

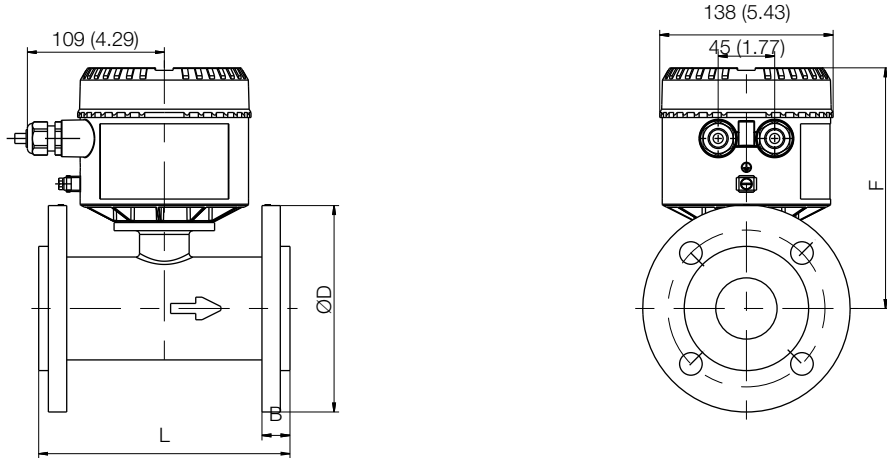

G12044

Fig. 28

Dimensions - Flange device, cast iron sensor housing – Design level "B"						Approx. weight	
Nominal diameter	Process connection	D	B	L ^(2) 3)	F	Remote	Integral
DN 25 (1")	EN 1092-1, PN 40 ¹⁾	115 (4.53)	23.1 (0.91)	200 (7.84)	180 (7.09)	5 (11)	6 (13)
	ASME B16.5, CL 150	115 (4.53)	23.1 (0.91)				
	ASME B16.5, CL 300	125 (4.92)	22 (0.87)				
	JIS 5K	95 (3.74)	15.5 (0.61)			4 (9)	5 (11)
	JIS10K, 20K	115 (4.53)	23.1 (0.91)			5 (11)	6 (13)
	AS2129 table D, E	115 (4.53)	23.1 (0.91)				
DN 32 (1 1/4")	EN 1092-1, PN 40 ¹⁾	150 (5.91)	25 (0.98)	200 (7.84)	185 (7.28)	6 (13)	7 (15)
	ASME B16.5 CL 150	150 (5.91)	25 (0.98)				
	ASME B16.5 CL 300	135 (5.31)	23 (0.91)				
	JIS 5K, 10K, 20K	150 (5.91)	25 (0.98)				
	AS2129 table D, E	150 (5.91)	25 (0.98)				
DN 40 (1 1/2")	EN 1092-1, PN 40 ¹⁾	150 (5.91)	23.5 (0.93)	200 (7.84)	190 (7.48)	7 (15)	8 (18)
	ASME B16.5 CL 150	150 (5.91)	23.5 (0.93)				
	ASME B16.5 CL 300	155 (6.10)	25 (0.98)			8 (18)	9 (20)
	JIS 5K	120 (4.72)	17.5 (0.69)			5 (11)	6 (13)
	JIS 10K	140 (5.51)	21.5 (0.85)			6 (13)	7 (15)
	JIS 20K	140 (5.51)	23.5 (0.93)				
	AS2129 table D	150 (5.91)	23.5 (0.93)			7 (15)	8 (18)
	AS2129 table E	135 (5.31)	23.5 (0.93)			5 (11)	6 (13)

Tolerance for L: +0 / -3 mm (+0 / -0.018 inch)

Dimensions - Flange device, cast iron sensor housing — Design level "B"							Approx. weight	
Nominal diameter	Process connection	D	B	L ^(2) 3)	F	Remote	Integral	
DN 50 (2")	EN 1092-1, PN 40 ¹⁾	165 (6.50)	27 (1.06)	200 (7.84)	193 (7.60)	9 (20)	10 (22)	
	ASME B16.5 CL 150	165 (6.50)	27 (1.06)					
	ASME B16.5 CL 300	165 (6.50)	27 (1.06)					
	JIS 5K	130 (5.12)	20 (0.79)			6 (13)	7 (15)	
	JIS 10K	165 (6.50)	27 (1.06)					
	JIS 20K	155 (6.10)	24 (0.94)					
	AS2129 table D, E	150 (5.91)	18.5 (0.73)					
DN 65 (2 1/2")	EN 1092-1, PN16, PN 40 ¹⁾	185 (7.28)	30 (1.18)	200 (7.87)	207 (8.15)	11 (24)	12 (26)	
	ASME B16.5 CL 150	180 (7.09)	30 (1.18)					
	ASME B16.5 CL 300	190 (7.48)	29 (1.14)			11 (24)	12 (26)	
	JIS 5K, 10K, 20K	185 (7.28)	30 (1.18)			11 (24)	12 (26)	
	AS2129 table D, E	165 (6.50)	18 (0.71)			9 (20)	10 (22)	
DN 80 (3")	EN 1092-1, PN 40 ¹⁾	205 (8.07)	30 (1.18)	200 (7.87)	211 (8.31)	13 (29)	14 (31)	
	ASME B16.5 CL 150	205 (8.07)	30 (1.18)					
	ASME B16.5 CL 300	210 (8.27)	33 (1.30)					
	JIS 5K, 10K	205 (8.07)	30 (1.18)			13 (29)	14 (31)	
	JIS 20K	200 (7.87)	28.5 (1.12)			12 (26)	13 (29)	
	AS2129 table D, E	205 (8.07)	30 (1.18)			13 (29)	14 (31)	
DN 100 (4")	EN 1092-1, PN 16 ¹⁾	235 (9.25)	29 (1.14)	250 (9.84)	242 (8.53)	15 (33)	15.5 (34)	
	EN 1092-1, PN 40 ¹⁾	235 (9.25)	28 (1.10)					
	ASME B16.5 CL 150	235 (9.25)	29 (1.14)			17 (37)	17.5 (39)	
	ASME B16.5 CL 300	255 (10.04)	38.5 (1.52)			15 (33)	15.5 (34)	
	JIS 5K	200 (7.87)	24 (0.94)			25 (55)	25.5 (56)	
	JIS 10K, 20K	235 (9.25)	29 (1.14)			12 (26)	13 (29)	
	AS2129 table D, E	235 (9.25)	29 (1.14)			15 (33)	16 (35)	
DN 125 (5")	EN 1092-1, PN 16 ¹⁾	270 (10.63)	38.5 (1.52)	250 (9.84)	254 (10.0)	20 (44)	21 (46)	
	EN 1092-1, PN 40 ¹⁾	270 (10.63)	36 (1.42)					
	ASME B16.5 CL 150	270 (10.63)	38.5 (1.52)					20 (44)
	ASME B16.5 CL 300	280 (11.02)	42 (1.65)			20 (44)	21 (46)	
	JIS 5K, 10K, 20K	270 (10.63)	38.5 (1.52)			31 (68)	32 (70)	
	AS2129 table D, E	270 (10.63)	38 (1.50)			20 (44)	21 (46)	

Tolerance for L: +0 / -3 mm (+0 / -0.018 inch)

1) Other pressure ratings on request.

2) If a grounding ring is fitted (attached to one side of the flange), dimension L increases by 5 mm (0.197 inch).

3) If protection plates are fitted (attached to both sides of the flange), dimension L increases by 10 mm (0.394 inch).

Dimensions - Flange device, cast iron sensor housing – Design level "B"						Approx weight	
Nominal diameter	Process connection	D	B	L ^(2) 3)	F	Remote	Integral
DN 250 (10")	EN 1092-1, PN 10 ¹⁾	395 (15.55)	37 (1.46)	450 (17.72)	326 (12.83)	48 (106)	49 (108)
	EN 1092-1, PN 16 ¹⁾	405 (15.94)	37 (1.46)			48 (106)	49 (108)
	EN 1092-1, PN 25 ¹⁾	425 (16.73)	40 (1.57)			59 (130)	60 (132)
	EN 1092-1, PN 40 ¹⁾	450 (17.72)	47 (1.85)			89 (196)	90 (198)
	ASME B16.5, CL 150	405 (15.94)	45.5 (1.79)			70 (154)	71 (156)
	ASME B16.5, CL 300	444.5 (17.50)	61 (2.40)			95 (209)	96 (211)
	JIS 5K, 10K	405 (15.94)	37 (1.46)			48 (106)	49 (108)
	JIS 20K	430 (16.93)	39 (1.45)			60 (132)	61 (135)
	AS2129 table D, E	405 (15.94)	37 (1.46)			48 (106)	49 (108)
DN 300 (12")	EN 1092-1, PN 10, PN 16 ¹⁾	475 (18.70)	38.5 (1.52)	500 (19.68)	351 (13.82)	70 (154)	71 (156)
	EN 1092-1, PN 25 ¹⁾	485 (19.09)	44 (1.73)			84 (185)	85 (187)
	EN 1092-1, PN 40 ¹⁾	515 (20.28)	58 (2.28)			94 (207)	95 (209)
	ASME B16.5, CL 150	485 (19.09)	50.5 (1.99)			110 (242)	111 (245)
	ASME B16.5, CL 300	521 (20.51)	69 (2.72)			140 (308)	141 (311)
	JIS 5K, 10K	475 (18.70)	38.5 (1.52)			60 (132)	61 (134)
	JIS 20K	480 (18.90)	42 (1.65)			80 (176)	81 (178)
	AS2129 table D, E	475 (18.70)	38.5 (1.52)			60 (132)	61 (134)
DN 350 (14")	EN 1092-1, PN 10 ¹⁾	505 (19.88)	35 (1.38)	550 (21.65)	374 (14.72)	74 (163)	75 (165)
	EN 1092-1, PN 16 ¹⁾	520 (20.47)	40 (1.57)			86 (190)	87 (192)
	EN 1092-1, PN 25 ¹⁾	555 (21.85)	47 (1.85)			121 (267)	122 (269)
	ASME B16.5, CL 150	533 (20.98)	54 (2.13)			103 (227)	104 (229)
	ASME B16.5, CL 300	584 (22.99)	80 (3.15)			196 (432)	197 (434)
	JIS 5K	480 (18.90)	29 (1.14)			59 (130)	60 (132)
	JIS 10K	490 (19.29)	31 (1.22)			63 (139)	64 (141)
	JIS 20K	540 (21.26)	45 (1.77)			100 (220)	101 (222)
	AS2129 table D	525 (20.67)	27 (1.06)			68 (150)	69 (152)
	AS2129 table E	525 (20.67)	38 (1.50)			86 (189)	87 (192)
DN 400 (16")	EN 1092-1, PN 10 ¹⁾	565 (22.24)	37 (1.46)	600 (23.62)	398 (15.67)	93 (205)	94 (207)
	EN 1092-1, PN 16 ¹⁾	580 (22.83)	43 (1.69)			109 (240)	110 (242)
	EN 1092-1, PN 25 ¹⁾	620 (24.41)	53 (2.09)			162 (357)	163 (359)
	ASME B16.5, CL 150	597 (23.50)	57 (2.24)			130 (287)	131 (289)
	ASME B16.5, CL 300	648 (25.50)	88 (3.46)			262 (577)	263 (579)
	JIS 5K	540 (21.26)	29 (1.14)			72 (158)	73 (160)
	JIS 10K	560 (22.05)	33 (1.30)			84 (185)	85 (187)
	JIS 20K	605 (23.82)	51 (2.01)			137 (302)	138 (304)
	AS2129 table D	580 (22.83)	30 (1.20)			86 (189)	87 (191)
	AS2129 table E	580 (22.83)	39 (1.54)			102 (225)	103 (227)

Tolerance for L: DN 150 ... 200 +0 / -3 mm (+0 / -0.018 inch), DN 250 ... 600 +0 / -5 mm (+0 / -0.197 inch)

ProcessMaster FEP610

Electromagnetic flowmeter

Dimensions - Flange device, cast iron sensor housing – Design level "B"						Approx weight	
Nominal diameter	Process connection	D	B	L ^{2) 3)}	F	Remote	Integral
DN 450 (18")	EN 1092-1, PN 10 ¹⁾	615 (24.21)	41 (1.61)	600 (23.62)	423 (16.65)	111 (245)	112 (247)
	EN 1092-1, PN 16 ¹⁾	640 (25.20)	47 (1.85)			136 (300)	137 (302)
	EN 1092-1, PN 25 ¹⁾	670 (26.38)	59 (2.32)			208 (458)	209 (460)
	ASME B16.5, CL 150	635 (25.00)	66 (2.60)			144 (317)	145 (319)
	ASME B16.5, CL 300	711 (27.99)	93 (3.66)			311 (685)	312 (687)
	JIS 5K	605 (23.82)	29 (1.14)			86 (189)	87 (192)
	JIS 10K	620 (24.41)	35 (1.38)			101 (222)	102 (224)
	JIS 20K	675 (26.75)	53 (2.09)			173 (381)	174 (383)
	AS2129 table D	640 (25.20)	30 (1.18)			100 (220)	101 (222)
	AS2129 table E	640 (25.20)	40 (1.57)			123 (271)	124 (273)
DN 500 (20")	EN 1092-1, PN 10 ¹⁾	670 (26.38)	43 (1.96)	600 (23.62)	450 (17.72)	128 (282)	129 (284)
	EN 1092-1, PN 16 ¹⁾	715 (28.15)	51 (2.01)			188 (414)	189 (416)
	EN 1092-1, PN 25 ¹⁾	730 (28.74)	63 (2.48)			247 (544)	248 (546)
	ASME B16.5, CL 150	698.5 (27.50)	69 (2.72)			171 (377)	172 (379)
	ASME B16.5, CL 300	775 (30.51)	99 (3.90)			364 (802)	365 (804)
	JIS 5K	655 (25.79)	24 (0.94)			94 (207)	95 (209)
	JIS 10K	675 (26.57)	35 (1.38)			127 (280)	128 (282)
	JIS 20K	730 (28.74)	47 (1.85)			198 (436)	199 (438)
	AS2129 table D	705 (27.76)	34 (1.34)			126 (277)	127 (280)
	AS2129 table E	705 (27.76)	43 (1.69)			165 (364)	166 (366)
DN 600 (24")	EN 1092-1, PN 10 ¹⁾	780 (30.71)	47 (1.85)	800 (31.50)	505 (19.88)	184 (405)	185 (408)
	EN 1092-1, PN 16 ¹⁾	840 (33.07)	60 (2.36)			298 (657)	299 (259)
	EN 1092-1, PN 25 ¹⁾	845 (33.27)	73 (2.87)			395 (871)	396 (873)
	ASME B16.5, CL 150	813 (32.01)	80 (3.15)			276 (608)	277 (610)
	ASME B16.5, CL 300	914 (35.98)	118 (4.65)			616 (1358)	617 (1360)
	JIS 5K	770 (30.31)	31 (1.22)			138 (304)	139 (306)
	JIS 10K	795 (31.30)	37 (1.46)			186 (410)	187 (412)
	JIS 20K	845 (33.27)	59 (2.32)			270 (595)	271 (597)
	AS2129 table D	825 (32.48)	47 (1.85)			186 (410)	187 (412)
	AS2129 table E	825 (32.48)	53 (2.09)			263 (579)	264 (582)

Tolerance for L: DN 250 ... 600 +0 / -5 mm (+0 / -0.197 inch)

1) Other pressure ratings on request.

2) If a grounding ring is fitted (attached to one side of the flange), dimension L increases by 5 mm (0.197 inch).

3) If protection plates are fitted (attached to both sides of the flange), dimension L increases by 10 mm (0.394 inch).

Transmitter

Features

- 4 ... 20 mA current output.
- Current output in the event of an alarm can be configured to 21 ... 22.6 mA (NAMUR NE43).
- Measuring range: Can be configured between 0.02 ... $2 \times Q_{\max DN}$.
- Operating mode for flow measurement can be configured.
- Programmable digital output. Can be configured as frequency output, pulse output or binary output.
- Damping: 0 ... 100 s configurable (1τ).
- Low flow cut-off: 0 ... 20 % for current and pulse output.
- Empty pipe detection¹⁾.
- Simulation of current and binary output (manual process execution).

1) Requirements for Empty Pipe detector function:
The conductivity of the fluid must be $\geq 20 \mu\text{S/cm}$
Signal cable length must be $\leq 50 \text{ m}$ (164 ft)
Nominal diameter must be $\geq \text{DN } 10$

LCD indicator (option)

- High-contrast LCD indicator.
- Display of the current flow rate as well as the total flow rate.
- Application-specific visualizations which the user can select. Two operator pages can be configured to display multiple values in parallel.
- Plain text fault diagnostics
- Menu-guided parameterization with four buttons.
- "Easy Set-up" function for fast commissioning.
- Parameterization of the device through the front glass with the housing closed.

IP rating

- IP 65 / IP 67 in accordance with EN 60529

Vibration

In accordance with EN 60068-2

- Maximum deflection: 0.15 mm (0.006 inch) in the 10 ... 58 Hz range
- Maximum acceleration: 2 g¹⁾, in the 58 ... 150 Hz range

1) Peak load

Temperature Data

Ambient temperature range

-30 ... 60 °C (-22 ... 140 °F)

Storage temperature range

-30 ... 70 °C (-22 ... 158 °F)

NOTE

When operating below -20 °C (-4 °F), the LCD display can no longer be read and the electronics should be operated with as few vibrations as possible.

Full functionality is assured at temperatures above -20 °C (-4 °F).

Housing design

Integral mount design	
Housing	Plastic, RAL 9002 (light gray)
Cable gland	Polyamide

Remote mount design	
Housing	Cast aluminum, painted
Paint	Paint coat $\geq 80 \mu\text{m}$ thick, RAL 9002 (light gray)
Cable gland	Polyamide
Weight	1.8 kg (3.97 lb)

ProcessMaster FEP610 Electromagnetic flowmeter

Dimensions

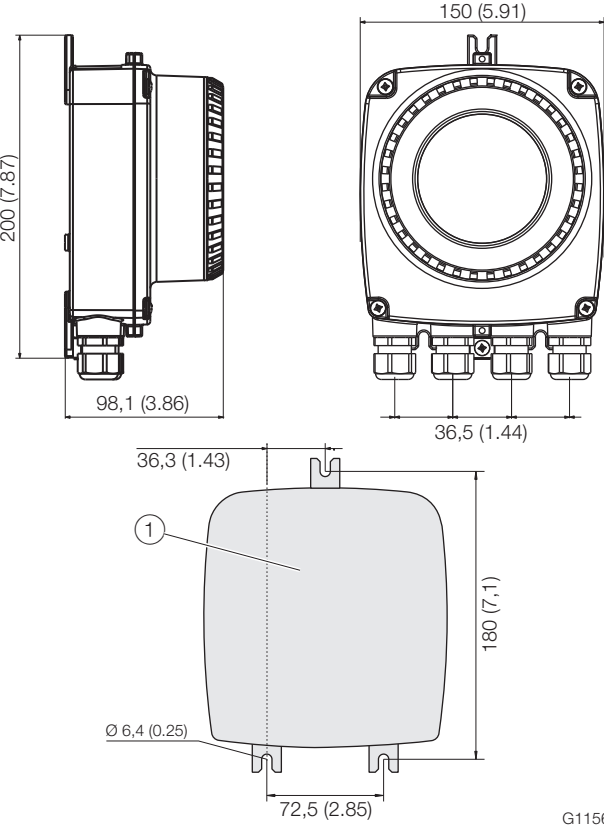

G11568

Fig. 30: Mounting dimensions (remote mount design)
① Hole pattern for mounting holes

Electrical connections

Connection diagram

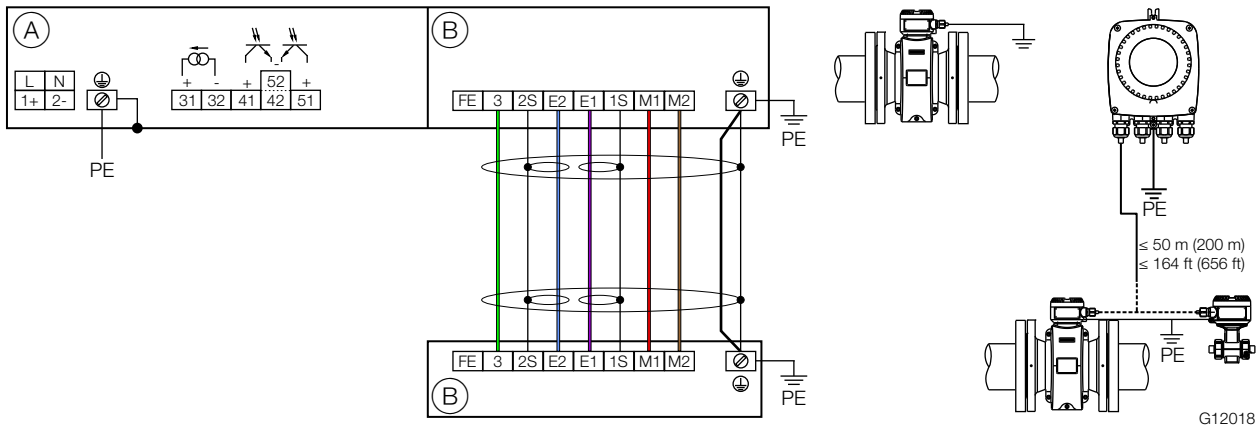

Fig. 31: Electrical connections
 (A) Connections for power supply and outputs (B) Connections for signal cable (remote mount design only)

NOTE

For detailed information about grounding the transmitter and the flowmeter sensor, please refer to chapter "Grounding" in the Commissioning instruction or the operating instruction.

Connections for the power supply

AC power supply	
Terminal	Function / comments
L	Phase
N	Neutral conductor
PE / ⊕	Protective earth (PE)

DC voltage supply	
Terminal	Function / comments
1+	+
2-	-
PE / ⊕	Protective earth (PE)

Connections for outputs

Terminal	Function / comments
31 / 32	Active current output The current output is "active" mode. The source to drive the 20 mA loop is in-built in the transmitter.
41 / 42	Passive digital output DO1 The output can be configured as a pulse output, frequency output or switch output on site.
51 / 52	Passive digital output DO2 The output can be configured as a pulse output, frequency output or switch output on site.
⊕	Functional earth

Connections for the signal cable

Only for remote mount design.

Terminal	Function / comments	Color
FE	Not connected	—
3	Measurement potential	green
2S	Shield for E2	—
E2	Signal line	blue
E1	Signal line	violet
1S	Shield for E1	—
M1	Magnet coil	brown
M2	Magnet coil	red
⊕	Shield	—
—	Not connected	orange / yellow

ProcessMaster FEP610

Electromagnetic flowmeter

Electrical data for inputs and outputs

Power supply L / N, 1+ / 2-

AC power supply	
Terminals	L / N
Operating voltage	100 ... 240 V AC (-15 % / +10 %), 47 ... 64 Hz
Power consumption	< 20 VA
Inrush current	8.8 A

DC voltage supply	
Terminals	1+ / 2-
Operating voltage	24 ... 48V DC (-10 % / +10 %)
Ripple	< 5 %
Power consumption	< 10 W
Inrush current	5.6 A

Current output 31 / 32

Can be configured for outputting mass flow, volume flow.

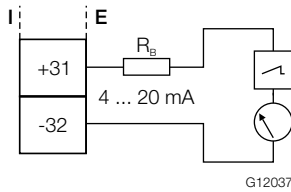

Fig. 32: Connection example active current output 31 / 32 (I = internal, E = external, R_B = load)

Current output	Active
Terminals	31 / 32
Output signal	4 ... 20 mA
Load R_B	$0 \Omega \leq R_B \leq 650 \Omega$

Digital output 41 / 42, 51 / 52

Can be configured as pulse, frequency or binary output.

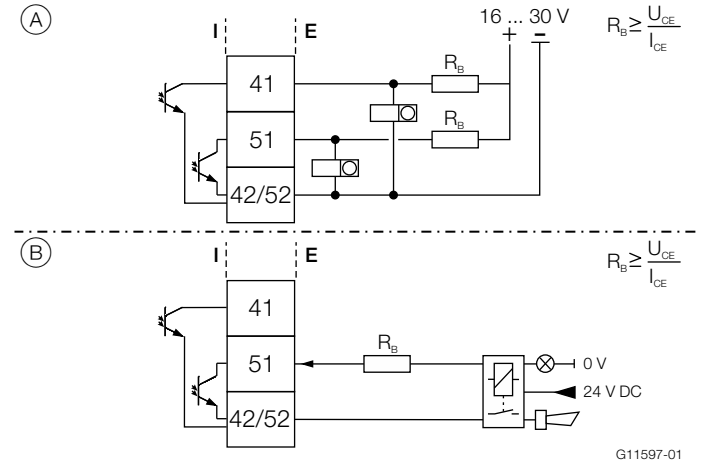

Fig. 33: Connection example (I = internal, E = external, R_B = load)

(A) Passive digital output 41 / 42, 51 / 52 as pulse or frequency output

(B) Passive digital output 51 / 52 as binary output

NOTE

- Terminals 42 / 52 have the same ground potential. Digital outputs 41 / 42 and 51 / 52 are not electrically isolated from each other.
- If you are using a mechanical counter, we recommend setting a pulse width of ≥ 30 ms and a maximum frequency of $f_{max} \leq 3$ kHz.

Pulse / frequency output (passive)	
Terminals	41 / 42, 51 / 52
U_{max}	30 V DC
I_{max}	25 mA
f_{max}	10.5 kHz
Pulse width	0.1 ... 2000 ms

Binary output (passive)	
Terminals	41 / 42, 51 / 52
U_{max}	30 V DC
I_{max}	25 mA
Switching function	Can be configured using software as: System alarm, empty pipe alarm, max. / min. alarm, flow direction signaling, others

Ordering Information

ProcessMaster FEP611

Electromagnetic Flowmeter system, integral mount

	ProcessMaster FEP611	7,8	9,10	11	12,13,14,15	...	75,76
Explosion Protection Certification							
Without		Y0					
Housing Type / Housing Material / Cable Glands							
Integral / Single compartment / Plastic / M20 x 1.5			V1				
Integral / Single compartment / Plastic / NPT 1/2 in.			V2				
Sensor Style							
Standard Sensor Housing				F			
Meter size							
DN 3 (1/10 in.)							0003
DN 4 (5/32 in.)							0004
DN 6 (1/4 in.)							0006
DN 8 (5/16 in.)							0008
DN 10 (3/8 in.)							0010
DN 15 (1/2 in.)							0015
DN 20 (3/4 in.)							0020
DN 25 (1 in.)							0025
DN 32 (1-1/4 in.)							0032
DN 40 (1-1/2 in.)							0040
DN 50 (2 in.)							0050
DN 65 (2-1/2 in.)							0065
DN 80 (3 in.)							0080
DN 100 (4 in.)							0100
DN 125 (5 in.)							0125
DN 150 (6 in.)							0150
DN 200 (8 in.)							0200
DN 250 (10 in.)							0250
DN 300 (12 in.)							0300
DN 350 (14 in.)							0350
DN 400 (16 in.)							0400
DN 450 (18 in.)							0450
DN 500 (20 in.)							0500
DN 600 (24 in.)							0600
DN 700 (28 in.)							0700
DN 750 (30 in.)							0750
DN 800 (32 in.)							0800
DN 900 (36 in.)							0900
DN 1000 (40 in.)							1000
DN 1050 (42 in.)							1050

Continued on next page

ProcessMaster FEP610

Electromagnetic flowmeter

	ProcessMaster FEP611	7,8	...	12,13,14,15	16,17	18,19	20	21	22	...	75,76
Meter size (continuation)											
DN 1100 (44 in.)				1100							
DN 1200 (48 in.)				1200							
DN 1400 (54 in.)				1400							
DN 1500 (60 in.)				1500							
DN 1600 (66 in.)				1600							
DN 1800 (72 in.)				1800							
DN 2000 (80 in.)				2000							
Process Connection Type											
Flanges DIN PN 6					1) D0						
Flanges DIN PN 10					D1						
Flanges DIN PN 16					D2						
Flanges DIN PN 25					D3						
Flanges DIN PN 40					D4						
Flanges ASME CL 150, B16.5 ≤ DN 600, B16.47 series B > DN600					A1						
Flanges ASME CL 300, B16.5 ≤ DN 600, B16.47 series B > DN600					A3						
Flanges JIS 10K					J1						
Flanges JIS 5K					J2						
Flanges JIS 20K					J3						
Liner Material											
Hard rubber					4) R2						
Soft rubber					5) R4						
ETFE					2) E1						
PTFE					T1						
PFA					3) P1						
Others					Z9						
Process Connection Material											
Carbon steel									B		
Stainless steel								6)	C		
Others									Z		
Electrode Design											
Standard										1	
Pointed head								7)	5		
Others										9	
Measuring Electrodes Material											
Hast. C-4 (2.4610)											D
Titanium											F
Tantalum											G
Hast. B-3 (2.4600)											H
Platinum-Iridium											J
Stainless steel 316Ti (1.4571)											S
Others											Z

Continued on next page

ProcessMaster FEP611	7,8	...	23	24	25,26	27	28	29,30	31	32,33	34,35,36	37,38,39	40,41,42	43,44	45,46	...	75,76
Grounding Electrode / Full Pipe Detection																	
No grounding electrode / No full pipe detection			0														
Grounding electrode / No full pipe detection			2														
Others			9														
Grounding Accessories																	
Without				A													
Grounding ring (1 off), mounted to flange			8)	B													
Grounding ring (2 off), mounted to flange			8)	C													
Others				Z													
Protection Class Transmitter / Protection Class Sensor																	
Standard / IP 67							70										
Power Supply																	
100 ... 230 AC / 24 V DC, 50 Hz								F									
100 ... 230 AC / 24 V DC, 60 Hz								G									
Display																	
Without																	0
Display with Keypad																	2
Outputs																	
Current output (active), 2 Digital outputs(passive)																	A6
Design Level																	
Specified by ABB																	A
Specified by ABB																	B
Usage Certifications																	
Without																	C0
Inspection certificate 3.1 acc. EN 10204																	C2
Others																	CZ
Calibration Certifications																	
ABB Standard																	CMA
3rd party witnessed calibration																	CMW
Other Usage Certifications																	
Meter tube with PED certificate																	CRP
Potable Water and Food & Beverage Approvals																	
Without																	CWY
Sensor Length																	
ABB Standard																	J6
Other Options																	
Without																	KO

Continued on next page

ProcessMaster FEP610

Electromagnetic flowmeter

ProcessMaster FEP611		7,8	...	47,48	49,50,51	52,53,54	55,56,57	58,59,60	61,62,63	64,65,66	67,68	69,70,71	72,73,74	75,76
Documentation Language														
German				M1										
English				M5										
Language package Western Europe / Scandinavia				MW										
Language package Eastern Europe				ME										
Others				MZ										
Pressure Bearing Parts Material Source														
Standard					MS0									
Tests and Reports														
Without						CR0								
Pressure test acc. to DIN						CPD								
Configuration Type														
Parameters set to factory defaults								NC1						
Parameters set customer specific								NCC						
Transmitter Software Function Package														
Standard									NFS					
Calibration Type														
0.5 % factory calibration									9)	RCC				
Signal Cable														
Without												SC0		
Device Identification Plate														
Adhesive label													TC	
Others													TZ	
Temperature Range of Installation / Ambient Temperature Range														
Standard / -20 ... 60 °C (-4 ... 140 °F)													10)	TK1
Number of Testpoints														
2 Points														TV2
3 Points														TV3
5 Points														TV5
Verification Capability														
disabled														V0

1) Available from DN 1000 (40 in.)

2) Available from DN 25 ... 600

3) Available from DN 3 ... 200

4) Available from DN 15

5) Available from DN 50

6) Material: Refer to data sheet. Available with design level A

7) Available from DN 10 ... 400

8) Available with sensor size ≤ DN 600 (24 in.) and PTFE / Thick-PTFE / ETFE / PFA liner material. For material, refer to data sheet

9) 2 points calibration will be done. If more than 2 testpoints are required, please specify 3 or 5 points with option "Number of Testpoints"

10) Max. fluid temperature with standard sensor design:

130 °C (266 °F) with PTFE, PFA, ETFE;

90 °C / 80 °C (194 °F / 176 °F) with hard rubber;

60 °C (140 °F) with soft rubber

ProcessMaster FEP612

Electromagnetic Flowmeter system, remote mount

	7,8	9,10	11	12,13,14,15	...	74,75
Explosion Protection Certification						
Without	Y0					
Housing Type / Housing Material / Cable Glands						
Remote / Plastic / M20 x 1.5		P1				
Remote / Plastic / NPT 1/2 in.		P2				
Sensor Style						
Standard Sensor Housing			F			
Meter size						
DN 3 (1/10 in.)				0003		
DN 4 (5/32 in.)				0004		
DN 6 (1/4 in.)				0006		
DN 8 (5/16 in.)				0008		
DN 10 (3/8 in.)				0010		
DN 15 (1/2 in.)				0015		
DN 20 (3/4 in.)				0020		
DN 25 (1 in.)				0025		
DN 32 (1-1/4 in.)				0032		
DN 40 (1-1/2 in.)				0040		
DN 50 (2 in.)				0050		
DN 65 (2-1/2 in.)				0065		
DN 80 (3 in.)				0080		
DN 100 (4 in.)				0100		
DN 125 (5 in.)				0125		
DN 150 (6 in.)				0150		
DN 200 (8 in.)				0200		
DN 250 (10 in.)				0250		
DN 300 (12 in.)				0300		
DN 350 (14 in.)				0350		
DN 400 (16 in.)				0400		
DN 450 (18 in.)				0450		
DN 500 (20 in.)				0500		
DN 600 (24 in.)				0600		
DN 700 (28 in.)				0700		
DN 750 (30 in.)				0750		
DN 800 (32 in.)				0800		
DN 900 (36 in.)				0900		
DN 1000 (40 in.)				1000		
DN 1050 (42 in.)				1050		

Continued on next page

ProcessMaster FEP610

Electromagnetic flowmeter

	ProcessMaster FEP610	7,8	...	12,13,14,15	16,17	18,19	20	21	22	...	77,78
Meter size (continuation)											
DN 1100 (44 in.)				1100							
DN 1200 (48 in.)				1200							
DN 1400 (54 in.)				1400							
DN 1500 (60 in.)				1500							
DN 1600 (66 in.)				1600							
DN 1800 (72 in.)				1800							
DN 2000 (80 in.)				2000							
Process Connection Type											
Flanges DIN PN 6					1) D0						
Flanges DIN PN 10					D1						
Flanges DIN PN 16					D2						
Flanges DIN PN 25					D3						
Flanges DIN PN 40					D4						
Flanges ASME CL 150, B16.5 ≤ DN 600, B16.47 series B > DN600					A1						
Flanges ASME CL 300, B16.5 ≤ DN 600, B16.47 series B > DN600					A3						
Flanges JIS 10K					J1						
Flanges JIS 5K					J2						
Flanges JIS 20K					J3						
Liner Material											
Hard rubber					4) R2						
Soft rubber					5) R4						
ETFE					2) E1						
PTFE					T1						
PFA					3) P1						
Others					Z9						
Process Connection Material											
Carbon steel							B				
Stainless steel						6)	C				
Others							Z				
Electrode Design											
Standard								1			
Pointed head								7) 5			
Others								9			
Measuring Electrodes Material											
Hast. C-4 (2.4610)										D	
Titanium										F	
Tantalum										G	
Hast. B-3 (2.4600)										H	
Platinum-Iridium										J	
Stainless steel 316Ti (1.4571)										S	
Others										Z	

Continued on next page

ProcessMaster FEP612	7,8	...	23	24	25,26	27	28	29,30	31	32,33	34,35,36	37,38,39	40,41,42	43,44	...	77,78
Grounding Electrode / Full Pipe Detection																
No grounding electrode / No full pipe detection			8) 0													
Grounding electrode / No full pipe detection			8) 2													
Others			9													
Grounding Accessories																
Without				A												
Grounding ring (1 off), mounted to flange			8)	B												
Grounding ring (2 off), mounted to flange			8)	C												
Others				Z												
Protection Class Transmitter / Protection Class																
Sensor																
IP 67 / IP 67					70											
IP 67 / IP 68				9)	76											
IP 67 / IP 68, signal cable fitted and potted				10)	77											
Power Supply																
Without						Y										
Display																
Without							0									
Outputs																
Without								Y0								
Design Level																
Specified by ABB									A							
Specified by ABB									B							
Usage Certifications																
Without										C0						
Inspection certificate 3.1 acc. EN 10204										C2						
Others										CZ						
Calibration Certifications																
ABB Standard											CMA					
3rd party witnessed calibration											CMW					
Other Usage Certifications																
Meter tube with PED certificate												CRP				
Potable Water and Food & Beverage Approvals																
Without													CWY			
Power Supply Line Frequency																
50 Hz (to be specified in case no Tx is ordered)															11)	F5
60 Hz (to be specified in case no Tx is ordered)															12)	F6

Continued on next page

ProcessMaster FEP610

Electromagnetic flowmeter

ProcessMaster FEP612 7,8 ... 45,46 47,48 49,50 51,52,53 54,55,56 57,58,59 60,61,62 63,64,65 66,67,68 ... 77,78	
Sensor Length	
ABB Standard	J6
Other Options	
Without	K0
Documentation Language	
German	M1
English	M5
Language package Western Europe / Scandinavia	MW
Language package Eastern Europe	ME
Others	MZ
Pressure Bearing Parts Material Source	
Standard	MS0
Tests and Reports	
Without	CRO
Pressure test acc. to DIN	CPD
Configuration Type	
Parameters set to factory defaults	NC1
Parameters set customer specific	NCC
Transmitter Software Function Package	
Standard	NFS
Calibration Type	
0.5 % factory calibration	13) RCC
Signal Cable	
Without	SC0
5 m (approx. 15 ft)	SC1
10 m (approx. 30 ft)	SC2
15 m (approx. 49 ft)	SC3
20 m (approx. 66 ft)	SC4
25 m (approx. 82 ft)	SC5
30 m (approx. 98 ft)	SC6
35 m (approx. 115 ft)	SC7
40 m (approx. 131 ft)	SC8
50 m (approx. 164 ft)	SCA

Continued on next page

Device Identification Plate

Adhesive label	TC
Others	TZ

Temperature Range of Installation / Ambient Temperature Range

Standard / -20 ... 60 °C (-4 ... 140 °F)	14) TK1
--	---------

Number of Testpoints

2 Points	TV2
3 Points	TV3
5 Points	TV5

Verification Capability

disabled	V0
----------	----

- 1) Available from DN 1000 (40 in.)
- 2) Available from DN 25 ... 600 (1 ... 24 in.)
- 3) Available from DN 3 ... 200 (1/10 ... 8 in.)
- 4) Available from DN 15 (1/2 in.)
- 5) Available from DN 50 (2 in.)
- 6) Material: Refer to data sheet. Available with design level A
- 7) Available from DN 10 ... 400 (3/8 ... 16 in.)
- 8) Available with sensor size ≤ DN 600 (24 in.) and PTFE / Thick-PTFE / ETFE / PFA liner material. For material, refer to data sheet
- 9) Only available with remote transmitter, sealing compound (optional) D141B038U01
- 10) Only available with remote transmitter
- 11) 50 Hz (to be specified in case no Tx is ordered)
- 12) 60 Hz (to be specified in case no Tx is ordered)
- 13) 2 points calibration will be done. If more than 2 testpoints are required, please specify 3 or 5 points with option "Number of Testpoints"
- 14) Max. fluid temperature with standard sensor design:
 - 130 °C (266 °F) with PTFE, PFA, ETFE;
 - 90 °C / 80 °C (194 °F / 176 °F) with hard rubber;
 - 60 °C (140 °F) with soft rubber

ProcessMaster FEP610



Electromagnetic flowmeter

Remote transmitter FET612

FET612 Electromagnetic Flowmeter, remote transmitter for ProcessMaster FEP610.

	7,8	9,10	11,12	13	14	15,16	17,18,19	20,21	22,23	24,25	26,27,28
Remote transmitter FET612											
Explosion Protection Certification											
Without	Y0										
Housing Type / Housing Material / Cable Glands											
Field-mount / Single compartment / Aluminium / 4 x M20 x 1.5		F1									
Field-mount / Single compartment / Aluminium / 4 x NPT 1/2 in.		F2									
Protection Class Transmitter / Protection Class Sensor											
Standard / IP 67			70								
Power Supply											
100- 240 AC; 24 - 48 DC, 50 Hz					F						
100- 240 AC; 24 - 48 DC, 60 Hz					G						
Display											
Without					0						
Display with Keypad					2						
Outputs											
Current output (active), 2 Digital Outputs (passive)						A6					
Potable Water and Food & Beverage Approvals											
Without							CWY				
Other Options											
Without								K0			
Documentation Language											
German									M1		
English									M5		
Language package Western Europe / Scandinavia									MW		
Language package Eastern Europe									ME		
Device Identification Plate											
Adhesive label										TC	
Others										TZ	
Temperature Range of Installation / Ambient Temperature Range											
Standard / -20 ... 60 °C (-4 ... 140 °F)											TK1

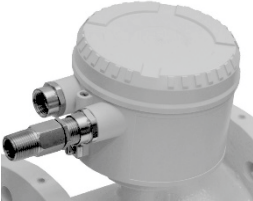
Accessories

Description	Order code
<p>Infrared service port adapter FZA100</p>  <p>G10788</p>	FZA100
<p>Installation set for NPT 1/2" cable gland. For sealing the cable conduit during outdoor installation.</p>  <p>G12058</p>	3KXF081300L0001
<p>Adapter M20x1.5 to 1/2"NPT</p>  <p>G12059</p>	D365B269U01
Signal cable	D173D031U01

Trademarks

™ Hastelloy C is a trademark of Haynes International

Contact us

ABB Limited

Process Automation

Howard Road, St. Neots
Cambridgeshire, PE19 8EU
UK

Tel: +44 (0)870 600 6122

Fax: +44 (0)1480 213 339

Mail: enquiries.mp.uk@gb.abb.com

ABB Inc.

Process Automation

125 E. County Line Road
Warminster, PA 18974
USA

Tel: +1 215 674 6000

Fax: +1 215 674 7183

ABB Automation Products GmbH

Process Automation

Dransfelder Str. 2
37079 Goettingen
Germany

Tel: +49 551 905-0

Fax: +49 551 905-777

ABB Engineering (Shanghai) Ltd.

Process Automation

No. 4528, Kangxin Highway, Pudong
New District
Shanghai, 201319,
P.R. China

Tel: +86(0) 21 6105 6666

Fax: +86(0) 21 6105 6677

Mail: china.instrumentation@cn.abb.com

www.abb.com/flow

Note

We reserve the right to make technical changes or modify the contents of this document without prior notice.

With regard to purchase orders, the agreed particulars shall prevail. ABB does not accept any responsibility whatsoever for potential errors or possible lack of information in this document.

We reserve all rights in this document and in the subject matter and illustrations contained therein. Any reproduction, disclosure to third parties or utilization of its contents in whole or in parts – is forbidden without prior written consent of ABB.

Copyright© 2016 ABB

All rights reserved

3KXF231600R1001













Sales



Service



Our offering:

	Actuators and Positioners		Analytical Instruments
	Device Management, Fieldbus and Wireless		Flow Measurement
	Force Measurement		Level Measurement
	Natural Gas Measurement		Pressure Measurement
	Recorders and Controllers		Temperature Measurement

HMI – Automação e Instrumentação, Lda.

Travessa da Indústria, nº 111
4780-573 Santo Tirso
PORTUGAL

Tel. +351 252 850 501
Fax. +351 300 013 487

Web: www.hmi.pt

Email: hmi@hmi.pt