



hmi

high-accuracy
measurement
instruments

FICHA TÉCNICA DE PRODUTO

PRODUCT DATASHEET

HMI – Automação e Instrumentação, Lda.

Travessa da Indústria, nº 111
4780-573 Santo Tirso
PORTUGAL

Tel. +351 252 850 501
Fax. +351 300 013 487

Web: www.hmi.pt

Email: hmi@hmi.pt

HygienicMaster FEH500 Electromagnetic Flowmeter

Measurement made easy

A first-class choice for
all hygienic applications



Intuitive operation

- Softkey-based functionality
- “Easy Set-up” function

Diagnostics for real-life situations

- Status messages in accordance with NAMUR
- Help texts in the display

Extended diagnostic functions

- Electrode deposit detection
- Gas bubble detection
- Conductivity monitoring
- Sensor temperature monitoring
- Trend analysis

Batch functionality

- Presetting counter, overrun correction, external start/stop, batch end contact

Maximum measuring accuracy

- Maximum measuring error: 0.2 % of rate

Universal transmitter

- Reduces spare parts inventory costs and storage costs

Flowmeter sensor featuring state-of-the-art memory technology

- Prevents errors and enables quick and reliable commissioning

Approvals for explosion protection

- In accordance with ATEX, IECEx
- In accordance with FM, cFM

HART, PROFIBUS PA, FOUNDATION fieldbus

- Access to all status information

ABB

ABB is an established world force in the design and manufacture of instrumentation for industrial process control.

Worldwide presence, comprehensive service and application-oriented know-how make ABB a leading supplier of flow measurement products.

Introduction**The industrial standard**

HygienicMaster is designed specifically to meet the requirements of the food and beverages and the pharmaceutical industries. The modular design concept offers flexibility, cost-saving operation and reliability whilst providing a long service life and exceptionally low maintenance.

Integration into ABB asset management systems and usage of the self-monitoring and diagnostic functions increases the plant availability and reduces downtimes.

Advanced diagnostic functions

Using its advanced diagnostic functions, the device monitors both its own operability and the process.

Limit values for the diagnostic parameters can be set locally. When these limits are exceeded, an alarm is tripped.

For further analysis, the diagnostic data can be read out via an advanced DTM. Critical states can, thus, be recognized early and appropriate measures can be taken.

As a result, productivity is increased and downtimes are avoided.

The status messages are classified in accordance with the NAMUR recommendations.

In the event of an error, a diagnostic-dependent help text appears on the display which considerably simplifies and accelerates the troubleshooting procedure. This gives maximum safety for the process.

Superior and reliable sensor

The variable connection concept and common sensor design provide for flexibility and easy installation.

The spare parts inventory and stockkeeping costs are reduced.

The reinforced PFA liner improves vacuum stability and prevents potential liner deformation, meeting the highest demands. The sensor is fully CIP/SIP cleanable up to 150 °C (302 °F).

Using advanced filtering methods, the device improves accuracy even under difficult conditions by separating the noise from the measuring signal. This leads to a max. measuring error of 0.2 % of rate.

Easy and quick commissioning

Advanced data storage inside the sensor eliminates the need to match sensor and transmitter in the field. The on-board sensor memory automatically identifies the transmitter. On power-on, the transmitter self-configuration function is run and replicates all sensor data and TAG-specific parameters into the transmitter. This eliminates the opportunity for errors and leads to an increased startup speed and reliability.

Intuitive, convenient navigation

The factory-set parameters can be modified quickly and easily via the user-friendly display and the non-contact buttons, without opening the housing. The "Easy Set-up" function reliably guides unpracticed users through the menu step by step.

The softkey-based functionality makes handling a breeze - it's just like using a cell phone. During the configuration, the permissible range of each parameter is indicated on the display and invalid entries are rejected.

Universal transmitter - powerful and flexible

The backlit display can be easily rotated without the need for any tools. The contrast is adjustable and the display fully configurable. The character size, number of lines and display resolution (number of decimals) can be set as required. In multiplex mode, several different display options can be pre-configured and invoked one after the other.

The smart modular design of the transmitter unit allows for easy disassembly without the need to unscrew cables or unplug connectors.

Whether count pulses, 20 mA signals or the status output are active or passive, the universal transmitter always delivers the correct signal. HART is used as the standard protocol.

Optionally, the transmitter is available with PROFIBUS PA or FOUNDATION fieldbus communication.

The universal transmitter simplifies the spare parts inventory and reduces the stockholding costs.

ScanMaster - the diagnostic tool

Can I rely on the measured values?

How can I determine the technical condition of my device?

ScanMaster can answer these frequently asked questions.

And ScanMaster allows you to easily check the device for proper functioning.

HygienicMaster - the first choice**Overview of the HygienicMaster series**

HygienicMaster is available in two series.

HygienicMaster 300 with basic functionality and HygienicMaster 500 with extended functions and options. The following table gives an overview.

	HygienicMaster	
	FEH300	FEH500
Measuring accuracy 0.4 % (optionally 0.2 %) of measured value	X	-
Measuring accuracy 0.3 % (optionally 0.2 %) of measured value	-	X
Batch functions Presetting counter, overrun correction, external start/stop, batch end contact	-	X
Other software functions Mass units, editable counter,	X	X
Two measuring ranges	-	X
Graphic display Line recorder function	X	X
Diagnostic functions Detection of gas bubbles or deposits on electrodes, conductivity monitoring, temperature monitoring, finger print, trend	-	X
Hardware options DN 1 ... 2	-	X
Startup functions Grounding check	-	X
Fieldbus PROFIBUS PA, FOUNDATION fieldbus	X	X
Verifications / Diagnostic tool ScanMaster	X	X







This data sheet describes HygienicMaster 500.

For HygienicMaster 300 refer to data sheet DS/FEH300.

Contents



1	HygienicMaster 500 - Overview of technology	4
2	Performance specifications	7
2.1	General	7
2.2	Reproducibility, response time	7
2.3	Transmitter	7
2.4	Flowmeter sizes, flow range	8
2.5	Filling function (batch)	9
3	Extended diagnostic functions	10
3.1	General	10
4	Functional and technical properties - HygienicMaster	14
4.1	Flowmeter sensor	14
4.2	Electrical connection	18
5	Ex-relevant specifications for operation in zones 1, 21, 22 / Div. 1	24
5.1	General	24
5.2	Electrical connection	25
5.3	Electrical data for operation in zones 1, 21, 22 / Div. 1	27
5.4	Temperature data	29
5.5	Special features of version designed for operation in Ex zone 1 / Div. 1	30
6	Ex-relevant specifications for operation in zones 2, 21, 22 / Div. 2	32
6.1	General	32
6.2	Electrical connection	33
6.3	Electrical data for operation in zones 2, 21, 22 / Div. 2	35
6.4	Temperature data	35
7	Explosion protection specifications for operation in areas with combustible dust	38
7.1	Information about using the device in areas with combustible dust	38
8	Installation requirements	39
8.2	Mounting	39
9	Dimensions	42
9.1	Flange, DN 3 ... 40 (1/10 ... 1 1/2")	42
9.2	Flange, DN 50 ... 100 (2 ... 4")	43
9.3	Wafer type, DN 3 ... 40 (1/10 ... 1 1/2")	44
9.4	Wafer type, DN 50 ... 100 (2 ... 4")	45
9.5	Variable process connections, DN 3 ... 40 (1/10 ... 1 1/2")	46
9.6	Variable process connections, DN 50 ... 100 (2 ... 4")	47
9.7	Adapter for variable process connections DN 3 ... 100 (1/10 ... 4")	48
9.8	1/8" sanitary connections DN 1 ... 2 (1/25 ... 3/32")	51
9.9	Transmitter housing (dual-compartment housing) model FET521 and FET525 Zone 2, Div 2	52
9.10	Transmitter housing (single-compartment housing) model FET521	52
10	Ordering information	53
10.1	HygienicMaster FEH511, FEH515 electromagnetic flowmeter, compact design	53
10.2	HygienicMaster FEH521, FEH525 electromagnetic flowmeter, remote mount design	56
10.3	FET521, FET525 external transmitter for HygienicMaster	59
10.4	FET501 transmitter plug-in module for ProcessMaster/HygienicMaster	60
10.5	Flowmeter sensor simulator - FXC4000	60
10.6	Ordering information Wafer type Accessories (Table H)	61
10.7	Diagnostic and verification software - ScanMaster FZC500	62
10.8	Infrared service port adapter type FZA100	63
10.9	Installation set for 2" pipe installation in dual-compartment field-mount housing	63
10.10	Installation set for NPT 1/2" cable gland	63



1 HygienicMaster 500 - Overview of technology

Model overview (compact design)		
FEH511 (without explosion protection)	FEH515 (with explosion protection, Zone 2 / Div. 2)	FEH515 (with explosion protection, Zone 1 / Div. 1)
Dual-compartment transmitter housing   Single-compartment transmitter housing	 	 
	ATEX / IEC Gases Zone 2 Dust Zone 21, 22	ATEX / IEC Gases Zone 1 Dust Zone 21, 22
	FM / cFM CL I Div 2 (NI, DIP)	FM / cFM CL I Div 1, 2 (XP, NI, DIP)
For further information about the instruments' explosion protection approval please refer to the Ex test certificates (available on the product CD or under www.abb.com/flow).		

Model number	FEH511, FEH515
Measured value error	Standard: 0,3 % of rate Option: 0.2 % of rate
Nominal diameter	DN 3 ... 100 (1/10 ... 4")
Process connection	Wafer type design DN 3 ... 100 (1/10 ... 4")
	Flange in acc. with DIN 2501 / EN 1092-1 DN 3 ... 100 (1/10 ... 4"), PN 10 ... 40
	Flange in acc. with ASME B16.5 DN 3 ... 100 (1/10 ... 4"), ASME CL 150, 300
	Flange in acc. with JIS DN 3 ... 100 (1/10 ... 4"), 10K
	Threaded pipe connection in acc. with DIN 11851 DN 3 ... 100 (1/10 ... 4"), PN 10 ... 40
	Welded spuds DN 3 ... 100 (1/10 ... 4"), PN 10 ... 40
	Tri-Clamp in acc. with DIN 32676 DN 3 ... 100 (1/10 ... 4"), PN 10 ... 40
	Tri-Clamp in acc. with ASME BPE DN 3 ... 100 (1/10 ... 4"), PN 10 ... 40
	External thread in acc. with ISO 228 / DIN 2999 DN 3 ... 25 (1/10 ... 1"), PN16
	1/8" sanitary connectors DN 1 ... 2 (1/25 ... 1/12")
Lining	PFA (vacuum-tight, from DN 3 (1/10")), PEEK (DN 1 ... 2 (1/25 ... 1/12"))
Conductivity	> 5 µS/cm (20 µS/cm for demineralized water) > 20 µS/cm with nominal diameter DN 1 ... 2 (1/25 ... 1/12")
Electrodes	CrNi steel 1.4571 (AISI 316Ti), 1.4539 [904L], Hastelloy B, Hastelloy C, platinum-iridium, tantalum, titanium
Process connection material	Flange: Stainless steel, variable process connections: 1.4404, With nominal diameter DN 1 ... 2 (1/25 ... 1/12") CrNi steel 1.4571 (AISI 316 Ti), PVC, POM
Degree of protection	IP 65, IP 67
Medium temperature	Flange: -25 ... 180 °C (-13 ... 356 °F), variable process connections: -25 ... 130 °C (-13 ... 266 °F)
Approvals	
Explosion protection approvals	ATEX / IEC Zone 1, 2, 21, 22 FM / cFM CL 1 Div. 1, CL 1 Div. 2
Pressure Equipment Directive 97/23/EC	Conformity assessment in accordance with category III, fluid group 1
CRN (Canadian Reg. Number)	On request
Certificates	
	FDA-approved materials
Transmitter	
Power supply	AC 100 ... 230 V (-15 / +10%), AC 24 V (-30 / +10%), DC 24V (-30 / +30%)
Current output	4 ... 20 mA, active or passive
Pulse output	Can be configured locally as active or passive using software
Switch output	Optocoupler, programmable function
Contact input	Optocoupler, programmable function
Display	Graphical display, fully configurable
Housing	Integral mount design, choice of single-compartment housing or dual-compartment housing
Communication	HART protocol (standard), PROFIBUS PA / FOUNDATION fieldbus (option)

For applications in the process industry, refer to the ProcessMaster 500 data sheet.

Model overview (remote mount design)	
Flowmeter sensor	
<p>FEH521 Flowmeter sensor (without explosion protection)</p>  <p>G00576</p>	<p>FEH525 Flowmeter sensor with explosion protection, Zone 2 / Div. 2)</p>  <p>G00576</p>
	<p>ATEX / IEC Gases Zone 2 Dust Zone 21, 22</p>
	<p>FM / cFM CL I Div 2 (NI, DIP) For further information about the instruments' explosion protection approval please refer to the Ex test certificates (available on the product CD or under www.abb.com/flow).</p>

Transmitter		
<p>FET521 Flowmeter sensor (without explosion protection)</p>  <p>G01084</p>	<p>FET525 Flowmeter sensor (with explosion protection, Zone 2 / Div. 2)</p>  <p>G00490</p>	<p>FET521 Flowmeter sensor (without explosion protection)</p>  <p>G01084</p>
	<p>ATEX / IEC Gases Zone 2 Dust Zone 21, 22</p>	
	<p>FM / cFM CL I Div 2 (NI, DIP) For further information about the instruments' explosion protection approval please refer to the Ex test certificates (available on the product CD or under www.abb.com/flow).</p>	

Housing variants for transmitter FET321:

- 1 Single-compartment housing
- 2 Dual-compartment housing

Flowmeter sensor	FEH521, FEH525
Measured value error	Standard: 0.3 % of rate). Optional: 0.2 % of rate
Nominal diameter	DN 3 ... 100 (1/10 ... 4")
Process connection	Wafer type design, DN 3 ... 100 (1/10 ... 4")
	Flange in acc. with DIN 2501 / EN 1092-1, DN 3 ... 100 (1/10 ... 4"), PN 10 ... 40
	Flange in acc. with ASME B16.5 DN 3 ... 100 (1/10 ... 4"), ASME CL 150, 300
	Flange in acc. with JIS DN 3 ... 100 (1/10 ... 4"), 10K
	Threaded pipe connection in acc. with DIN 11851 DN 3 ... 100 (1/10 ... 4"), PN 10 ... 40
	Weld stubs DN 3 ... 100 (1/10 ... 4"), PN 10 ... 40
	Tri-Clamp in acc. with DIN 32676 DN 3 ... 100 (1/10 ... 4"), PN 10 ... 40
	Tri-Clamp in acc. with ASME BPE DN 3 ... 100 (1/10 ... 4"), PN 10 ... 40
	External thread in acc. with ISO 228 / DIN 2999 DN 3 ... 25 (1/10 ... 1"), PN16 1/8" sanitary connectors DN 1 ... 2 (1/25 ... 1/12")
Lining	PFA (vacuum-tight, from DN 3 (1/10")), PEEK (DN 1 ... 2 (1/25 ... 1/12"))
Conductivity	> 5 µS/cm (20 µS/cm for demineralized water) > 20 µS/cm with nominal diameter DN 1 ... 2 (1/25 ... 1/12")
Electrodes	CrNi steel 1.4571 (AISI 316Ti), 1.4539 [904L], Hastelloy B, Hastelloy C, platinum-iridium, tantalum, titanium
Process connection material	Flange: Stainless steel, variable process connections: 1.4404, With nominal diameter DN 1 ... 2 (1/25 ... 1/12") CrNi steel 1.4571 (AISI 316 Ti), PVC, POM
Degree of protection	IP 65, IP 67 (NEMA 4X), IP 68
Medium temperature	Flange: -25 ... 180 °C (-13 ... 356 °F), variable process connections: -25 ... 130 °C (-13 ... 266 °F)
Approvals	
Explosion protection approvals	ATEX / IEC Zone 2, 21, 22 FM / cFM Cl 1Div. 2
Pressure Equipment Directive 97/23/EC	Conformity assessment in accordance with category III, fluid group 1
CRN (Canadian Reg. Number)	On request
Certificates	
	FDA-approved materials
Transmitter	
FET511, FET525	
Power supply	AC 100 ... 230 V (-15 / +10%), AC 24 V (-30 / +10%), DC 24V (-30 / +30%)
Current output	4 ... 20 mA, active or passive
Pulse output	Can be configured locally as active or passive using software
Switch output	Optocoupler, programmable function
Contact input	Optocoupler, programmable function
Display	Graphical display, fully configurable
Housing	Field-mount housing: choice of single-compartment housing or dual-compartment housing
Communication	HART protocol (standard), PROFIBUS PA / FOUNDATION fieldbus (option)

For applications in the process industry, refer to the **ProcessMaster 500** data sheet.

2 Performance specifications

2.1 General

2.1.1 Reference conditions according to EN 29104

Fluid temperature	20 °C (68 °F) ± 2 K
Ambient temperature	20 °C (68 °F) ± 2 K
Supply power	Nominal voltage acc. to name plate $U_n \pm 1 \%$, frequency $f \pm 1 \%$
Installation conditions	- Upstream >10 x DN, straight section - Downstream >5 x DN, straight section
Warm-up phase	30 min

2.1.2 Maximum measuring error

Pulse output

- Standard calibration:
 - ± 0.3 % of measured value, ± 0.02 % Q_{maxDN} (DN 3 ... 100)
 - ± 0.7 % of measured value, ± 0.02 % Q_{maxDN} (DN 1 ... 2)
- Optional calibration:
 - ± 0.2 % of measured value, ± 0.02 % Q_{maxDN} (DN 10 ... 100)

Q_{maxDN} : See table in Section 2.4, "Flowmeter sizes, flow range".

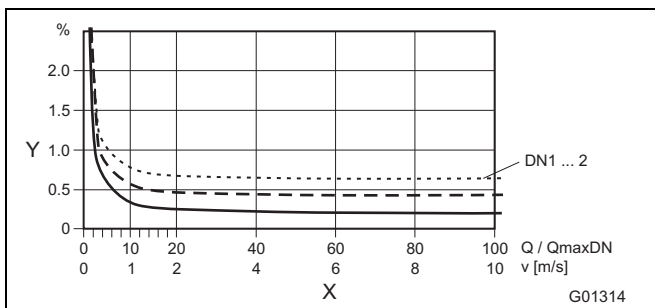

Fig. 1

- Y Accuracy ± of measured value in [%]
- X Flow velocity v in [m/s], Q / Q_{maxDN} [%]

Analog output effects

Same as pulse output plus ± 0.1 % of measured value ± 0.01 mA

2.2 Reproducibility, response time

Reproducibility	≤ 0.11 % of measured value, $t_{meas} = 100$ s, $v = 0.5 \dots 10$ m/s
Response time of current output with damping of 0.02 seconds	As step function 0 ... 99 % $5 \tau \geq 200$ ms at 25 Hz excitation frequency $5 \tau \geq 400$ ms at 12.5 Hz excitation frequency $5 \tau \geq 500$ ms at 6.25 Hz excitation frequency

2.3 Transmitter

2.3.1 Electrical properties

Supply power	AC 100 ... 230 V (-15 % / +10 %) AC 24 V (-30 % / +10 %) DC 24 V (-30 % / +30 %), ripple: < 5 %
Line frequency	47 ... 64 Hz
Excitation frequency	6 1/4 Hz, 7 1/2 Hz, 12 1/2 Hz, 15 Hz, 25 Hz, 30 Hz (50 / 60 Hz power supply)
Power consumption	(flowmeter sensor including transmitter) AC $S \leq 20$ VA DC $P \leq 12$ W (switch-on current 5.6 A)
Electrical connection	Screw terminals

2.3.1.1 Isolation of input/outputs

The current output, digital outputs DO1 and DO2, and digital input are electrically isolated from the flowmeter sensor input circuit and from each other. The same is valid for the signal outputs of the versions with PROFIBUS PA and FOUNDATION fieldbus.

2.3.1.2 Empty pipe detection

The "empty pipe detection" function requires:

A conductivity of the measured fluid $\geq 20 \mu\text{S/cm}$, a signal cable length ≤ 50 m (164 ft), a nominal diameter $DN \geq DN 10$, and the flowmeter sensor must not be provided with a preamplifier.

2.3.2 Mechanical properties

Integral mount design (transmitter mounted directly on the flowmeter sensor)	
Housing	Cast aluminum, painted
Paint	Paint coat $\geq 80 \mu\text{m}$ thick, RAL 9002 (light gray)
Cable gland	Polyamide Stainless steel (in the case of hazardous area design for ambient temperature of -40 °C (40 °F))
Remote mount design	
Housing	Cast aluminum, painted
Paint	Paint coat $\geq 80 \mu\text{m}$ thick, mid-section RAL 7012 (dark gray), front cover / rear cover RAL 9002 (light gray)
Cable gland	Polyamide Stainless steel (in the case of hazardous area design for ambient temperature of -40 °C (40 °F))
Weight	4.5 kg (9.92 lb)

2.3.2.1 Storage temperature, ambient temperature

Ambient temperature

- 20 ... 60 °C (-4 ... 140 °F) Standard range
- 40 ... 60 °C (-40 ... 140 °F) Extended range

Storage temperature

- 40 ... 70 °C (-40 ... 158 °F)

2.3.2.2 Protection class for transmitter housing

IP 65, IP 67, NEMA 4X

2.3.2.3 Vibration according to EN 60068-2

Transmitter

- In the range 10 ... 58 Hz with max. 0.15 mm (0.006 inch) deflection*
- In the range 58 ... 150 Hz max. 2 g acceleration*

* = Peak load

2.4 Flowmeter sizes, flow range

The flow range end value can be set between $0.02 \times Q_{\max DN}$ and $2 \times Q_{\max DN}$.

Nominal diameter		Min. flow range end value	$Q_{\max DN}$	Max. flow range end value
DN	"	$0.02 \times Q_{\max DN}$ (≈ 0.2 m/s)	0 ... ≈ 10 m/s	$2 \times Q_{\max DN}$ (≈ 20 m/s)
1	1/25	0,0012 l/min (0,00032 US gal/min)	0,6 l/min (0,16 US gal/min)	1,2 l/min (0,32 US gal/min)
1,5	1/16	0,024 l/min (0,0063 US gal/min)	1,2 l/min (0,32 US gal/min)	2,4 l/min (0,63 US gal/min)
2	1/12	0,04 l/min (0,0106 US gal/min)	2 l/min (0,53 US gal/min)	4 l/min (1,06 US gal/min)
3	1/10	0,08 l/min (0,02 US gal/min)	4 l/min (1,06 US gal/min)	8 l/min (2,11 US gal/min)
4	5/32	0,16 l/min (0,04 US gal/min)	8 l/min (2,11 US gal/min)	16 l/min (4,23 US gal/min)
6	1/4	0,4 l/min (0,11 US gal/min)	20 l/min (5,28 US gal/min)	40 l/min (10,57 US gal/min)
8	5/16	0,6 l/min (0,16 US gal/min)	30 l/min (7,93 US gal/min)	60 l/min (15,85 US gal/min)
10	3/8	0,9 l/min (0,24 US gal/min)	45 l/min (11,9 US gal/min)	90 l/min (23,78 US gal/min)
15	1/2	2 l/min (0,53 US gal/min)	100 l/min (26,4 US gal/min)	200 l/min (52,8 US gal/min)
20	3/4	3 l/min (0,79 US gal/min)	150 l/min (39,6 US gal/min)	300 l/min (79,3 US gal/min)
25	1	4 l/min (1,06 US gal/min)	200 l/min (52,8 US gal/min)	400 l/min (106 US gal/min)
32	1 1/4	8 l/min (2,11 US gal/min)	400 l/min (106 US gal/min)	800 l/min (211 US gal/min)
40	1 1/2	12 l/min (3,17 US gal/min)	600 l/min (159 US gal/min)	1200 l/min (317 US gal/min)
50	2	1,2 m ³ /h (5,28 US gal/min)	60 m ³ /h (264 US gal/min)	120 m ³ /h (528 US gal/min)
65	2 1/2	2,4 m ³ /h (10,57 US gal/min)	120 m ³ /h (528 US gal/min)	240 m ³ /h (1057 US gal/min)
80	3	3,6 m ³ /h (15,9 US gal/min)	180 m ³ /h (793 US gal/min)	360 m ³ /h (1585 US gal/min)
100	4	4,8 m ³ /h (21,1 US gal/min)	240 m ³ /h (1057 US gal/min)	480 m ³ /h (2113 US gal/min)

2.5 Filling function (batch)

The integrated filling function of the device allows you to record filling processes >3 seconds.

For this purpose, the filling quantity is given via an adjustable totalizer.

Filling can be started via either the digital input or the fieldbus.

The valve is triggered via one of the digital outputs and closed again once the preset filling quantity is reached.

The transmitter measures the overrun quantity and calculates the overrun correction from this.

Additionally, the low flow cut-off can be activated if required.

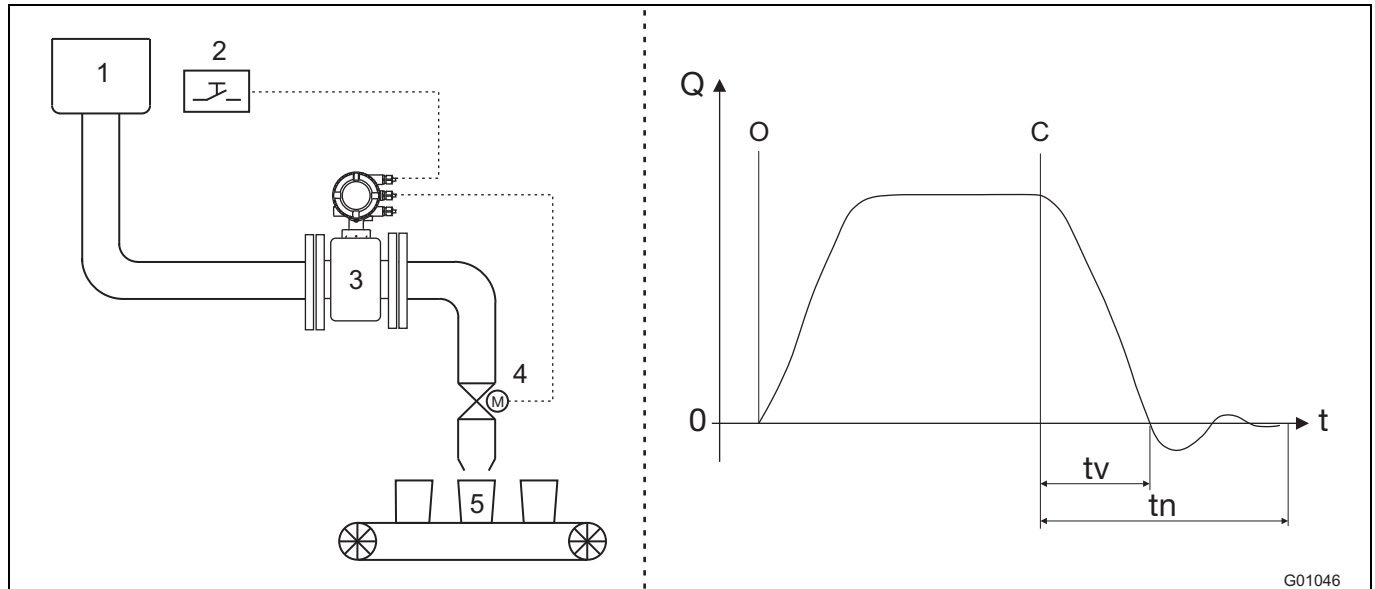

Fig. 2:

- 1 Supply tank
- 2 Start/stop contact (digital input)
- 3 Flowmeter sensor
- 4 Motor valve
- 5 Tank to be filled

- O Valve open (filling started)
- C Valve closed (fill quantity reached)
- t_v Valve closing time
- t_n Overrun time

G01046

3 Extended diagnostic functions

3.1 General



Important (Note)

- When using the extended diagnostic functions the external flowmeter sensor must not be provided with a preamplifier.

3.1.1 Detection of gas bubbles

Gas bubbles in the fluid are detected by using an adjustable maximum limit value. When this limit value is exceeded, an alarm is tripped via the programmable digital output, depending on the configuration.

Conditions for using the function:

- This function is available in the nominal diameter range ¹⁾ of DN 10 ... 300 (3/8 " ... 12 ").
- The signal cable length of the external transmitter must not exceed a maximum value of 50 m (164 ft) .
- For this function, the conductivity of the fluid must be in the range 20 $\mu\text{S}/\text{cm}$... 20,000 $\mu\text{S}/\text{cm}$.

Additional installation conditions:

- The flowmeter sensor can be installed either horizontally or vertically. Vertical installation is preferred.

1) The specified nominal diameter range is valid for ProcessMaster, only. The nominal diameter range valid for HygienicMaster is DN 10 ... 100 (3/8 " ... 4 ").

3.1.2 Electrode coating detection

This function provides the opportunity to detect coatings on the measuring electrodes by using an adjustable maximum limit value.

When the set limit value is exceeded, an alarm is tripped via the programmable digital output, depending on the configuration.

Conditions for using the function:

- This function is available in the nominal diameter range ²⁾ of DN 10 ... 300 (3/8 " ... 12 ").
- The signal cable length of the external transmitter must not exceed a maximum value of 50 m (164 ft) .
- For this function, the conductivity of the fluid must be in the range 20 $\mu\text{S}/\text{cm}$... 20,000 $\mu\text{S}/\text{cm}$.

Additional installation conditions:

- When using plastic tubes, install a grounding plate at the front and back of the device.

3.1.3 Conductivity monitoring

The conductivity of the fluid is monitored by using an adjustable minimum / maximum limit value.

When the value falls below or exceeds the set limit value, an alarm is tripped via the programmable digital output, depending on the configuration.

Conditions for using the function:

- This function is available in the nominal diameter range ¹⁾ of DN 10 ... 300 (3/8 " ... 12 ").
- The signal cable length of the external transmitter must not exceed a maximum value of 50 m (164 ft) .
- For this function, the conductivity of the fluid must be in the range 20 $\mu\text{S}/\text{cm}$... 20,000 $\mu\text{S}/\text{cm}$.

Additional installation conditions:

- When using plastic tubes, install a grounding plate at the front and back of the device.
- There must not be any deposits on the measuring electrodes.

1) The specified nominal diameter range is valid for ProcessMaster, only. The nominal diameter range valid for HygienicMaster is DN 10 ... 100 (3/8 " ... 4 ").

3.1.4 Electrode impedance monitoring

The impedance between the electrode and ground is monitored by using a minimum / maximum limit value. This enables the transmitter to detect an electrode fine short or leakage.

When the value falls below or exceeds the set limit value, an alarm is tripped via the programmable digital output, depending on the configuration.

Conditions for using the function:

- This function is available in the nominal diameter range ¹⁾ of DN 10 ... 300 (3/8 " ... 12 ").
- The signal cable length of the external transmitter must not exceed a maximum value of 50 m (164 ft) .
- For this function, the conductivity of the fluid must be in the range 20 $\mu\text{S}/\text{cm}$... 20,000 $\mu\text{S}/\text{cm}$.

Additional installation conditions:

- When using plastic tubes, install a grounding plate at the front and back of the device.
- There must not be any deposits on the measuring electrodes.
- The measuring tube must always be completely full, and the fluid must feature only minor conductivity variations.

3.1.5 Sensor measurements

This function includes the monitoring of the sensor temperature and the monitoring of the resistance of the flowmeter sensor's coils.

3.1.5.1 Sensor temperature monitoring

The temperature of the coils in the flowmeter sensor can be monitored by using adjustable minimum / maximum limit values. When a set limit value is exceeded, an alarm is tripped via the programmable digital output, depending on the configuration.

The coil temperature is a factor of the ambient and fluid temperatures. The measurement can, e.g., be used to monitor overtemperature due to the fluid. The coil temperature is measured indirectly via the coil DC resistance.

3.1.5.2 Monitoring of the sensor coil resistance

The coils in the flowmeter sensor can be monitored by using adjustable minimum / maximum limit values for the coil resistance. When a set limit value is exceeded, an alarm is tripped via the programmable digital output, depending on the configuration.

1) The specified nominal diameter range is valid for ProcessMaster, only. The nominal diameter range valid for HygienicMaster is DN 10 ... 100 (3/8 " ... 4 ").

3.1.6 Trend

The device has an internal memory where the measured value for the electrode deposits and the conductivity are cyclically stored as a data set with an adjustable time (1 min ... 45000 min). A maximum of 12 data sets is stored. When the thirteenth record is stored, the oldest data set is overwritten automatically.

The data sets can be read out or analyzed as a trend using the external diagnostic tool (ScanMaster).

3.1.7 Fingerprint

The "fingerprint" database integrated in the transmitter allows you to compare the values at the time of factory calibration or commissioning with the currently recorded values.

3.1.8 Checking the grounding

This function allows you to check the electrical grounding of the device.

While the check is in progress, no flow measurement can take place.

Conditions for using the function:

- The measuring tube must be completely full.
- No flow must occur in the flowmeter sensor.

Additional installation conditions:

- The flowmeter sensor must not be provided with a preamplifier.

4 Functional and technical properties - HygienicMaster

4.1 Flowmeter sensor

4.1.1 Protection type according to EN 60529

IP 65, IP 67, NEMA 4X

IP 68 (for external flowmeter sensors only)

4.1.2 Pipeline vibration according to EN 60068-2-6

For devices with integral mount design the following applies:
(transmitter mounted directly on the flowmeter sensor)

- In the 10 ... 58 Hz range with max. 0.15 mm (0.006 inch) deflection
- In the 58 ... 150 Hz max. 2 g acceleration (does not apply to DN1...2)

For devices with remote mount design the following applies:
Transmitter

- In the 10 ... 58 Hz range with max. 0.15 mm (0.006 inch) deflection
- In the 58 ... 150 Hz range with max. 2 g acceleration

Flowmeter sensor

- In the 10 ... 58 Hz range with max. 0.15 mm (0.006 inch) deflection
- In the 58 ... 150 Hz max. 2 g acceleration (does not apply to DN1...2)

4.1.3 Installation length

The flange devices comply with the installation lengths specified in VDI/VDE 2641, ISO 13359, or according to DVGW (process sheet W420, design WP, ISO 4064 short).

4.1.4 Signal cable (for external transmitters only)

A 5 m (16.4 ft) cable is supplied.

If you require more than 5 m (16.4 ft), a cable can be purchased using order number D173D027U01.

Alternatively, the cable with order number AD173D031U01 can be used for transmitters without explosion protection (model FEP321, FEH321) from DN15 and for transmitters for use in Zone 2 (model FEP325, FEH325) from DN15.

Preamplifier

Maximum signal cable length between flowmeter sensor and transmitter:

a) Without preamplifier:

- Max. 50 m (164 ft) for conductivity $\geq 5 \mu\text{S/cm}$

A preamplifier is required for cables $> 50 \text{ m}$ (164 ft).

b) With preamplifier

- Max. 200 m (656 ft) for conductivity $\geq 5 \mu\text{S/cm}$

4.1.5 Temperature range

Storage temperature

- 40 ... 70 °C (-40 ... 158 °F)

Min. permissible pressure as a function of fluid temperature

Lining	Nominal diameter	P _{operating} at mbar abs.	T _{operating} ¹⁾
PFA	DN 3 ... 100 (1/10 ... 4")	0	< 180 °C (356 °F)
PEEK	DN 1 ... 2 (1/25 ... 1/12")	0	< 120 °C (248 °F)

1) For CIP/SIP cleaning, higher temperatures are permitted for limited time periods; refer to the table titled "Maximum permissible cleaning temperature".

Max. permissible cleaning temperature

CIP cleaning	Flowmeter sensor lining	T _{max}	T _{max} minutes	T _{amb.}
Steam cleaning	PFA	150 °C (302 °F)	60	25 °C (77 °F)
Fluids	PFA	140 °C (284 °F)	60	25 °C (77 °F)

If the ambient temperature is $> 25 \text{ °C}$, the difference must be subtracted from the max. cleaning temperature. $T_{\text{max}} - \Delta \text{ °C}$.

($\Delta \text{ °C} = T_{\text{amb}} - 25 \text{ °C}$)

Max. permissible temperature shock

Lining	Max. temp. shock Temp. diff. in °C	Temp. gradient °C / min
PFA	Any	Any
PEEK	Any	Any

Max. ambient temperature as a function of fluid temperature**Important (Note)**

When using the device in potentially explosive areas, the additional temperature specifications in the section titled "Ex relevant specifications" on the data sheet or in the the separate Ex safety instructions (SM/FEX300/FEX500/ATEX/IECEX) or (SM/FEX300/FEX500/FM/CSA) must be observed.

Standard temperature design

Model	Process connection	Ambient temperature		Fluid temperature	
		Min. temp ¹⁾	Max. temp.	Min. temp.	Max. temp ²⁾
FEH511 FEH515	Flange	-20 °C (-4 °F)	60 °C (140 °F) 40 °C (104 °F)	-25 °C (-13 °F)	100 °C (212 °F) 130 °C (266 °F)
	Variable process connections	-20 °C (-4 °F)	60 °C (140 °F) 40 °C (104 °F)	-25 °C (-13 °F)	100 °C (212 °F) 130 °C (266 °F)
FEH521 FEH525	Flange	-20 °C (-4 °F)	60 °C (140 °F) 40 °C (104 °F)	-25 °C (-13 °F)	100 °C (212 °F) 130 °C (266 °F)
	Variable process connections	-20 °C (-4 °F)	60 °C (140 °F) 40 °C (104 °F)	-25 °C (-13 °F)	100 °C (212 °F) 130 °C (266 °F)

High temperature design (from nominal diameter DN 10 (3/8"))

Model	Process connection	Ambient temperature		Fluid temperature	
		Min. temp ¹⁾	Max. temp.	Min. temp.	Max. temp.
FEH511 FEH515	Flange	-20 °C (-4 °F)	60 °C (140 °F)	-25 °C (-13 °F)	180 °C (356 °F)
FEH521 FEH525	Flange	-20 °C (-4 °F)	60 °C (140 °F)	-25 °C (-13 °F)	180 °C (356 °F)

1) The following is valid for the low temperature design (option): -40°C (-40°F).

2) For CIP/SIP cleaning, higher temperatures are permitted for limited time periods; refer to the table "Max. permissible cleaning temperature" on page 14.

4.1.6 Material load

Limits for the permissible fluid temperature (TS) and permissible pressure (PS) are calculated on the basis of the lining and flange material used in the device (refer to the name plate on the device).

Process connection	Nominal diameter	PS _{max} bar (PSI)	TS
Wafer type	DN 3 ... 50 (1/10 ... 2")	40 (580)	-25 ... 130 °C (-13 ... 266 °F)
	DN 65 ... 100 (2 1/2 ... 4")	16 (232)	
Welded spuds	DN 3 ... 40 (1/10 ... 1 1/2")	40 (580)	-25 ... 130 °C (-13 ... 266 °F)
	DN 50, DN 80 (2", 3")	16 (232)	
	DN 65, DN 100 (2 1/2", 4")	10 (145)	
Threaded pipe connection conforming to DIN 11851	DN 3 ... 40 (1/10 ... 1 1/2")	40 (580)	-25 ... 130 °C (-13 ... 266 °F)
	DN 50, DN 80 (2", 3")	16 (232)	
	DN 65, DN 100 (2 1/2", 4")	10 (145)	
Tri-Clamp conforming to DIN 32676	DN 3 ... 50 (1/10 ... 2")	16 (232)	-25 ... 121 °C (-13 ... 250 °F)
	DN 65 ... 100 (2 1/2 ... 4")	10 (145)	
Tri-Clamp in acc. with ASME BPE	DN 3 ... 100 (1/10 ... 4")	10 (145)	-25 ... 130 °C (-13 ... 266 °F)
External thread ISO 228 / DIN 2999	DN 3 ... 25 (1/10 ... 1")	16 (232)	-25 ... 130 °C (-13 ... 266 °F)
OD tubing	DN 3 ... 50 (1/10 ... 2")	10 (145)	-25 ... 130 °C (-13 ... 266 °F)
1/8" sanitary connectors	DN 1 ... 2 (1/25 ... 1/12")	10 (145)	-10 ... 120 °C (-14 ... 248 °F)

DIN flange stainless steel to DN 100 (4")

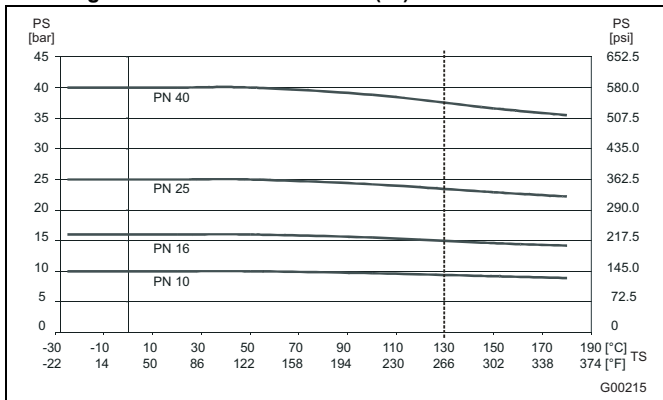

Fig. 3

ASME flange, stainless steel, up to DN 100 (4") (CL150 / 300)

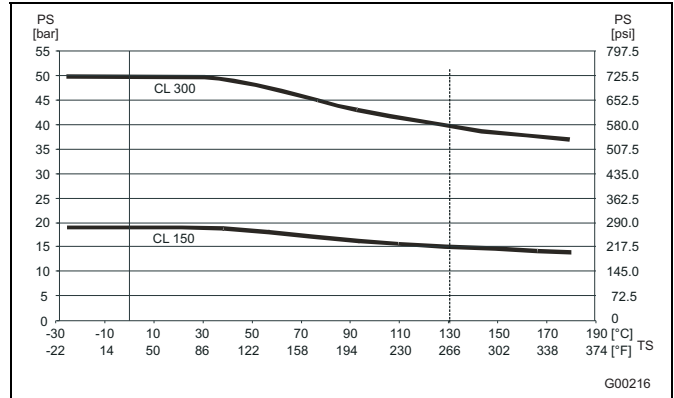

Fig. 4

For CIP / SIP cleaning, higher temperatures are permitted for limited time periods; refer to the table titled "Maximum permissible cleaning temperature".

JIS 10K-B2210 flange

Nominal diameter	Material	PN	TS	PS [bar]
25 ... 100 (1 ... 4")	Stainless steel	10	-25 ... 180 °C (-13 ... 356 °F)	10 (145 psi)

Wafer type design

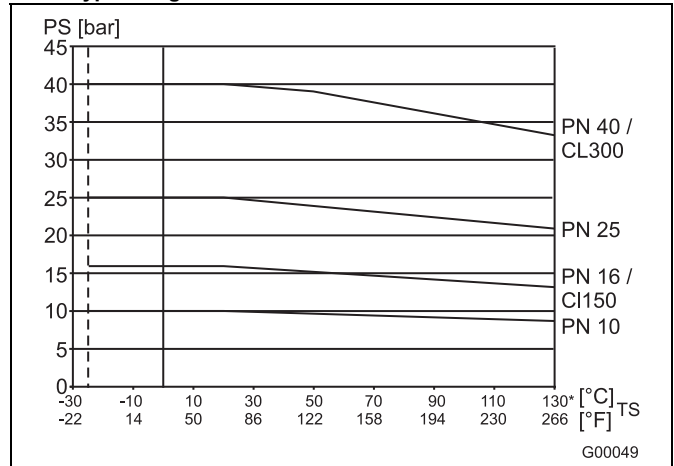

Fig. 5

JIS 10K-B2210 wafer type design

Nominal diameter	Material	PN	TS	PS [bar]
DN 32 ... 100 (1 1/4 ... 4")	1.4404	10	-25 ... 130 °C (-13 ... 266 °F)	10 (145 psi)
	1.4435			
	1.4301			

4.1.7 Mechanical properties

Parts that come into contact with fluid

Part	Standard	Option
Lining	PFA from DN 3 (1/10") PEEK DN 1 ... 2 (1/25 ... 1/12")	-
Signal and grounding electrode	CrNi steel 1.4539 (AISI 904L)	CrNi steel 1.4571 (AISI 316Ti) Hast. C-4 (2.4610) Hast. B-3 (2.4600) Titanium, tantalum, Platinum-iridium
Gaskets (for Weld stubs, threaded connection, Tri-Clamp, external threads)	EPDM (Ethylene-Propylene) with FDA approval, silicone with FDA approval (CIP-resistant, no oils or grease)	Silicone with FDA approval (option, oil or grease resistant) PTFE with FDA approval (DN 3 ... 8 (1/10 ... 5/16"))
Gasket for 1/8" sanitary connectors	PTFE	Viton (only in combination with PVC process connection)
Process connection		
- Welded spuds, Tri-Clamp, etc.	CrNi steel 1.4404 (AISI 316L)	-
- OD tubing	CrNi steel 1.4435 (AISI 316L)	-

Parts that do not come into contact with fluid

	Standard	Option
Flange	CrNi steel 1.4571 (AISI 316Ti)	-

Flowmeter sensor housing

	Standard
Housing	Deep-drawn housing CrNi steel 1.4301 (AISI 304), 1.4308
Terminal box	CrNi steel 1.4308 (AISI 304)
Meter tube	Stainless steel
Cable gland	Polyamide Stainless steel (in the case of hazardous area design for ambient temperature of -40 °C (40 °F))

4.2 Electrical connection

4.2.1 Model FEH511, FEH521, FET521 with HART protocol

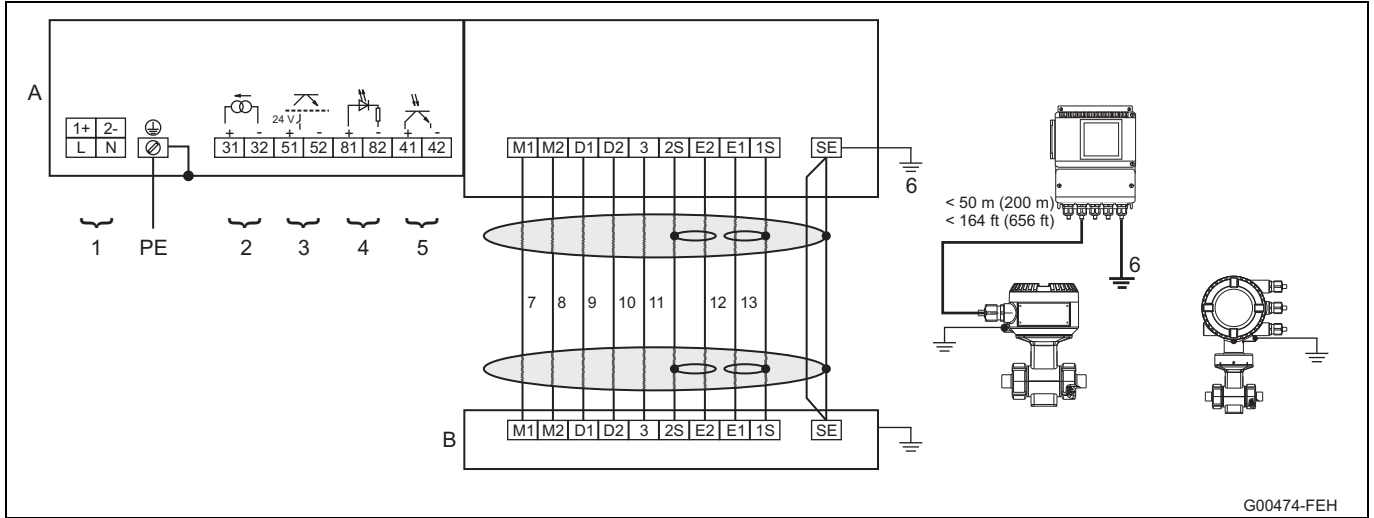

Fig. 6

- A **Transmitter**
- B **Flowmeter sensor**
- 1 **Power supply**
See name plate
- 2 **Current output (terminals 31 / 32)**
The current output can be operated in "active" or "passive" mode.
 - Active: 4 ... 20 mA, HART protocol (standard), load: $250\ \Omega \leq R \leq 650\ \Omega$
 - Passive: 4 ... 20 mA, HART protocol (standard), load: $250\ \Omega \leq R \leq 650\ \Omega$
 Supply voltage for the current output: minimum 11 V, maximum 30 V at terminals 31 / 32.
- 3 **Digital output DO1 (terminals 51 / 52) (pulse output or digital output)**
Function can be configured locally as "Pulse Output" or "Digital Output" using software. Factory setting is "Pulse Output".
The output can be configured as an "active" or "passive" output (in the case of the transmitter with the dual-compartment housing, the output is configured using the software; in the case of the transmitter with the single-compartment housing, it is configured by means of jumpers on the transmitter backplane).
Configuration using software.
 - Configuration as pulse output.
Max. pulse frequency: 5250 Hz.
Pulse width: 0.1 ... 2000 ms.
The pulse factor and pulse width are interdependent and are calculated dynamically.
 - Configuration as contact output
Function: System alarm, empty pipe alarm, max. / min. alarm, flow direction signaling, other
 - Configuration as "active" output
 $U = 19 \dots 21\text{ V}$, $I_{\text{max}} = 220\text{ mA}$, $f_{\text{max}} \leq 5250\text{ Hz}$
 - Configuration as "passive" output
 $U_{\text{max}} = 30\text{ V}$, $I_{\text{max}} = 220\text{ mA}$, $f_{\text{max}} \leq 5250\text{ Hz}$
- 4 **Digital input (terminals 81 / 82) (contact input)**
Function can be configured locally using software:
External output switch-off, external totalizer reset, external totalizer stop, other
Data for the optocoupler: $16\text{ V} \leq U \leq 30\text{ V}$, $R_i = 2\text{ k}\Omega$
- 5 **Digital output DO2 (terminals 41 / 42) (pulse output or digital output)**
Function can be configured locally as "Pulse Output" or "Digital Output" using software.
Factory setting is "Digital Output", flow direction signaling.
The output is always a "passive" output (optocoupler).
Data for the optocoupler: $U_{\text{max}} = 30\text{ V}$, $I_{\text{max}} = 220\text{ mA}$, $f_{\text{max}} \leq 5250\text{ Hz}$
- 6 Functional ground
- 7 Yellow
- 8 Brown
- 9 Green
- 10 Red
- 11 Blue
- 12 Orange
- 13 Violet

4.2.2 Model FEH511, FEH521, FET521 with PROFIBUS PA, FOUNDATION fieldbus

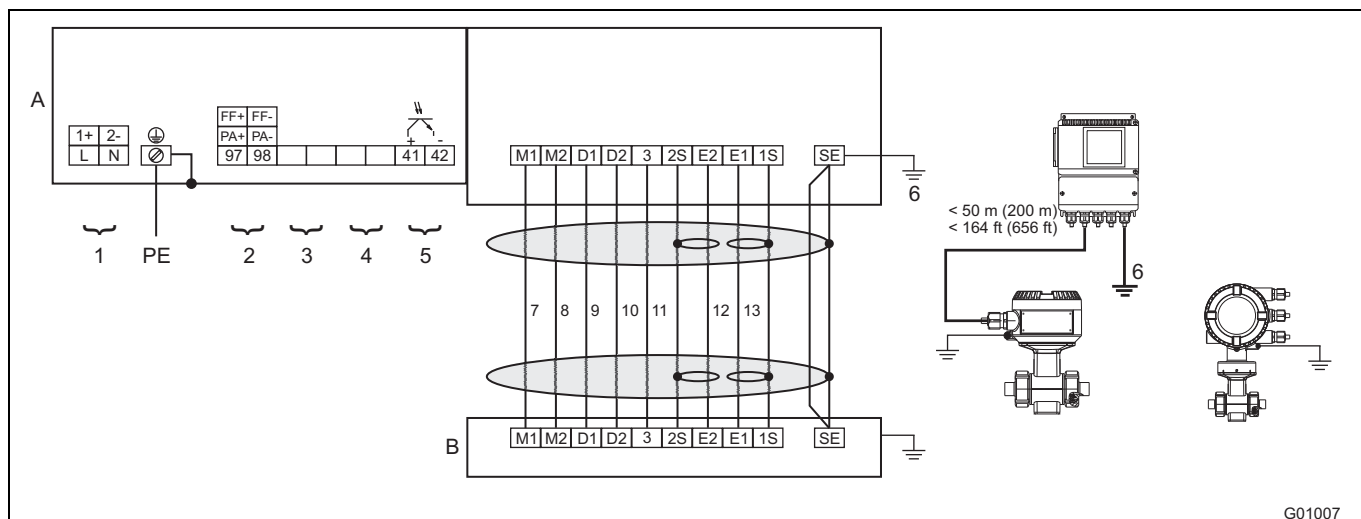

Fig. 7

A **Transmitter**B **Flowmeter sensor**1 **Power supply**

See name plate

2 **Digital communication (terminal 97 / 98)**• **PROFIBUS PA in acc. with IEC 61158-2 (PA+ / PA-)**

U = 9 ... 32 v, I = 10 mA (normal operation), I = 13 mA (in the event of an error / FDE)

Bus connection with integrated protection against polarity reversal

The bus address can be set via the DIP switches in the device (with dual-compartment transmitter housing only), the transmitter display or the fieldbus.

or

• **FOUNDATION fieldbus in acc. with IEC 61158-2 (FF+ / FF-)**

U = 9 ... 32 v, I = 10 mA (normal operation), I = 13 mA (in the event of an error / FDE)

Bus connection with integrated protection against polarity reversal

3 Not assigned

4 Not assigned

5 **Digital output DO2 (terminals 41 / 42) (pulse output or digital output)**

Function can be configured locally as "Pulse Output" or "Digital Output" using software.

Factory setting is "Digital Output", flow direction signaling.

The output is always a "passive" output (optocoupler).

Data for the optocoupler: $U_{\max} = 30 \text{ V}$, $I_{\max} = 220 \text{ mA}$, $f_{\max} \leq 5250 \text{ Hz}$

6 Functional ground

7 Brown

8 Red

9 Orange

10 Yellow

11 Green

12 Blue

13 Violet

G01007

4.2.3 Connection examples for the peripherals

Current output

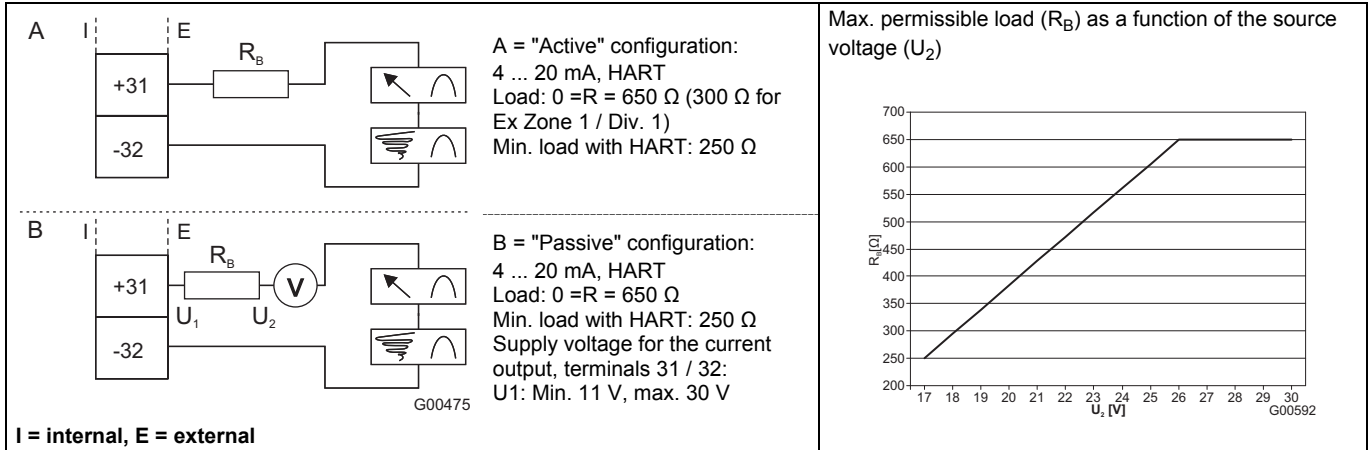

Fig. 8

Digital output DO1

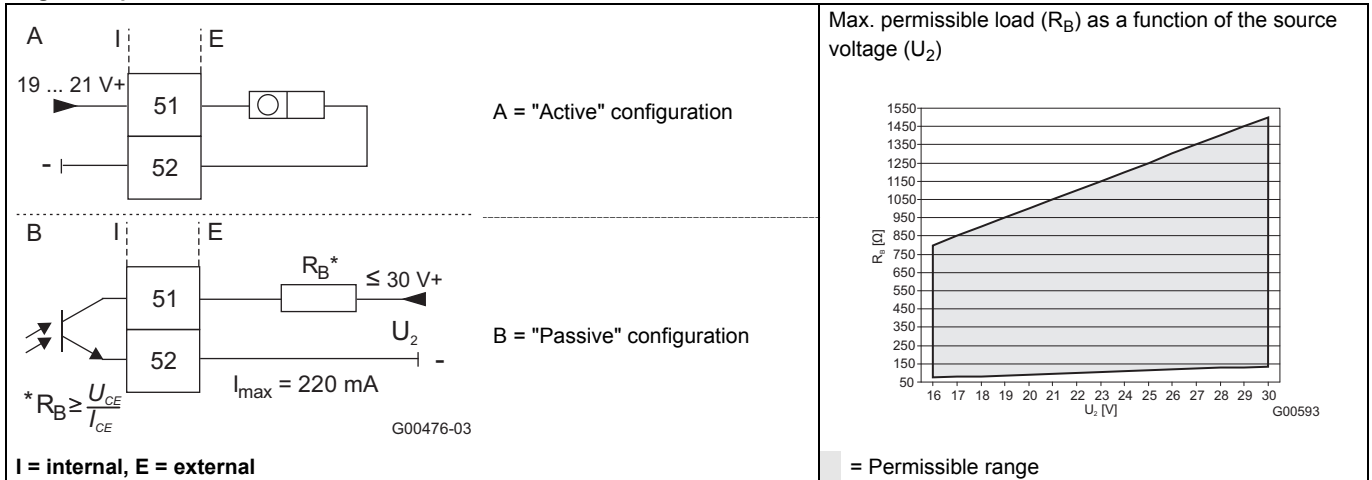

Fig. 9

Digital output DO2, e.g., for system monitoring, max. / min. alarm, empty meter tube or forward / reverse signal, or counting pulses (function can be configured using software)

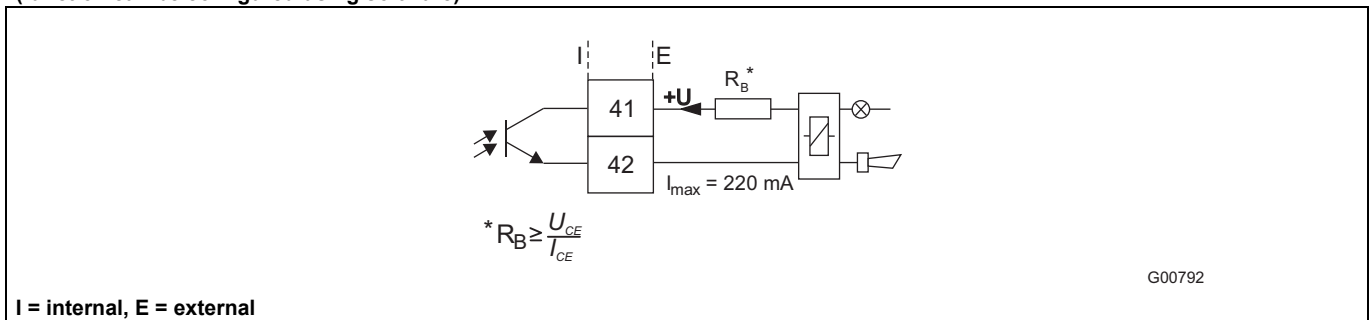

Fig. 10

Digital outputs DO1 and DO2, separate forward and reverse pulses

Digital outputs DO1 and DO2, separate forward and reverse pulses (alternative connection)

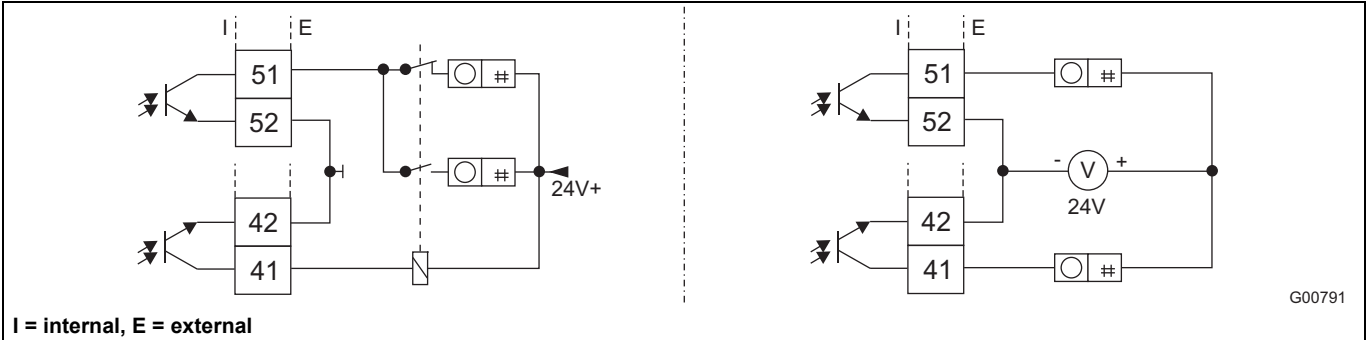

Fig. 11

Digital input for external output switch-off or external totalizer reset

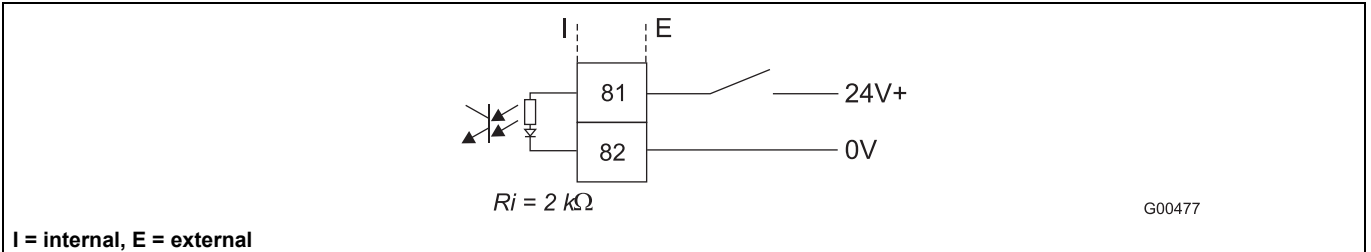

Fig. 12

PROFIBUS PA and FOUNDATION fieldbus

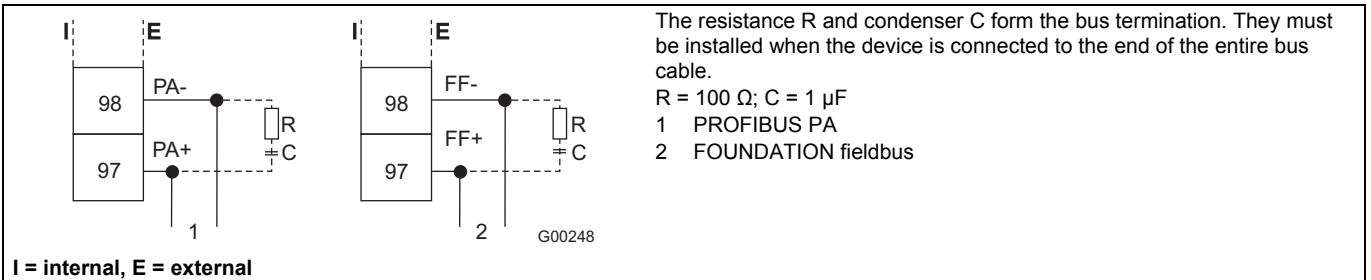

Fig. 13

Connection via M12 plug (only for PROFIBUS PA in non-hazardous areas)

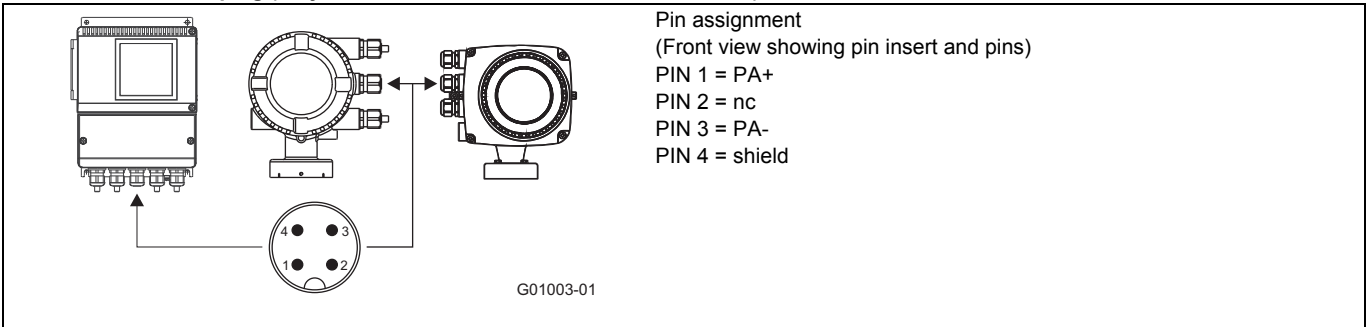

Fig. 14

Digital communication

The transmitter has the following options for digital communication:

HART protocol

The unit is registered with the HART Communication Foundation.

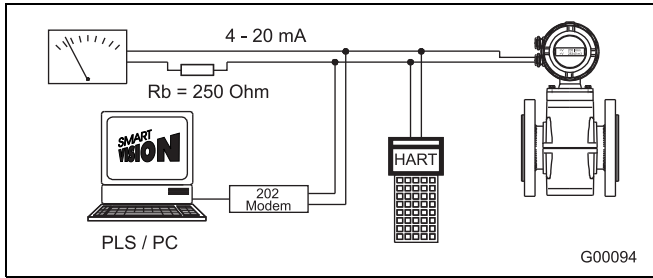

Fig. 15

HART protocol	
Configuration	Directly on the device Software DAT200 Asset Vision Basic (+ HART-DTM)
Transmission	FSK modulation on current output 4 ... 20 mA acc. to Bell 202 standard
Max. signal amplitude	1.2 mA _{SS}
Current output load	Min. 250 Ω, max. = 560 Ω
Cable	AWG 24 twisted
Max. cable length	1500 m
Baud rate	1,200 baud
Display	Log. 1: 1,200 Hz Log. 0: 2200 Hz

For additional information, see the separate interface description.

System integration

In conjunction with the DTM (Device Type Manager) available for the device, communication (configuration, parameterization) can occur with the corresponding framework applications according to FDT 1.21 (DAT200 Asset Vision Basic).

Other tool/system integrations (e.g., Emerson AMS/Siemens PCS7) are available upon request.

A free of charge version of the DAT200 Asset Vision Basic framework application for HART® or PROFIBUS is available upon request.

The required DTMs are contained on the DAT200 Asset Vision Basic DVD or in the DTM Library.

They can also be downloaded from www.abb.com/flow.

PROFIBUS PA protocol

The interface conforms to profile 3.01 (PROFIBUS standard, EN 50170, DIN 19245 [PRO91]).

PROFIBUS PA ID no.:	0x3430
Alternative standard ID no.:	0x9700 or 0x9740
Configuration	Directly on the device Software DAT200 Asset Vision Basic (+ PROFIBUS PA-DTM)
Transmission signal	Acc. to IEC 61158-2
Cable	Shielded, twisted cable (acc. to IEC 61158-2, types A or B are preferred)

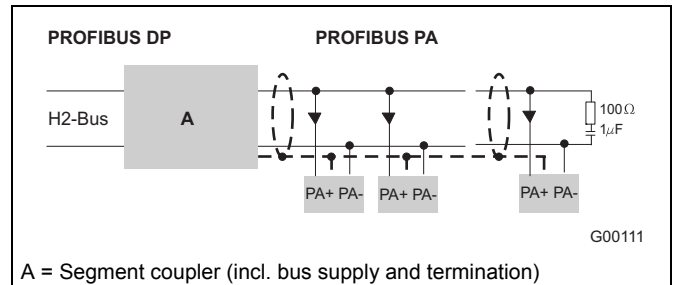

Fig. 16: Example for PROFIBUS PA interface connection

Bus topology

- Tree and/or line structure
- Bus termination: passive at both ends of the main bus line (RC element R = 100 Ω, C = 1 μF)

Voltage / current consumption

- Average current consumption: 10 mA
- In the event of an error, the integrated FDE function (=Fault Disconnection Electronic) integrated in the device ensures that the current consumption can rise to a maximum of 13 mA.
- The upper current limit is restricted electronically.
- The voltage on the bus line must lie in the range of 9 ... 32 V DC.

For additional information, see the separate interface description.

System integration

ABB provides three different GSD files (equipment master data) which can be integrated in the system.

Users decide at system integration whether to install the full range of functions or only part.

The change-over is done using the "ID-number selector" parameter.

ID number 0x9700, GSD file name: PA139700.gsd

ID number 0x9740, GSD file name: PA139740.gsd

ID number 0x3430, GSD file name: ABB_3430.gsd

The interface description appears on the CD included in the scope of supply.

The GSD files can also be downloaded from www.abb.com/flow.

The files required for operation can be downloaded from www.profibus.com.

FOUNDATION fieldbus (FF)

Interoperability test campaign no.	ITK 5.20
Manufacturer ID	0x000320
Device ID	0x0124
Configuration	<ul style="list-style-type: none"> • Directly on the device • Via services integrated in the system • National configurator
Transmission signal	Acc. to IEC 61158-2

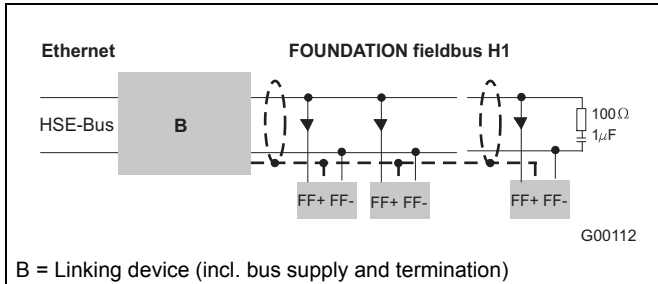

Fig. 17: Example for FOUNDATION fieldbus interface connection

Bus topology

- Tree and/or line structure
- Bus termination: passive at both ends of the main bus line (RC element R = 100 Ω, C = 1 μF)

Voltage / current consumption

- Average current consumption: 10 mA
- In the event of an error, the integrated FDE function (=Fault Disconnection Electronic) integrated in the device is ensures that the current consumption can rise to a maximum of 13 mA.
- Upper current limit: electronically restricted.
- The voltage on the bus line must lie in the range of 9 ... 32 V DC.

Bus address

The bus address is automatically assigned or can be set in the system manually.

The identifier (ID) is formed using a unique combination of manufacturer ID, device ID, and device serial number.

System integration

The following are required:

- DD (Device Description) file, which includes the device description.
- The CFF (Common File Format) file is required for engineering the segment. Engineering can be performed online or offline.

The interface description appears on the CD included in the scope of supply.

The files can also be downloaded from www.abb.com/flow.

The files required for operation can also be downloaded from <http://www.fieldbus.org>.

5 Ex-relevant specifications for operation in zones 1, 21, 22 / Div. 1

5.1 General

The device with dual-compartment transmitter housing (model name FEH515) is approved for operation in the following potentially explosive areas:

- ATEX / IECEx Zone 1, 21, 22
- FM Div.1
- cFM Div.1



Important (Note)

For detailed information on the individual approvals, refer to Section 1 „HygienicMaster 500 - Overview of technology“.



Important (Note)

The housing for the transmitter and flowmeter sensor must be connected to the potential equalization PA. The operator must ensure that when connecting the protective conductor (PE) no potential differences can occur between protective conductor and potential equalization (PA).

A temperature of 70 °C (158 °F) at the cable entry is assumed for the Ex calculations. Therefore, the cables used for the supply power and the signal inputs and outputs must have a minimum specification of 70 °C (158 °F).

For devices with remote mount design for use in FM / cFM Div. 1 or FM / cFM Div. 2 the signal cable between the flowmeter sensor and the transmitter must have a minimum length of 5 m (16.4 ft).

5.2 Electrical connection

5.2.1 Model FEH515 in Zone 1 / Div. 1 with HART protocol

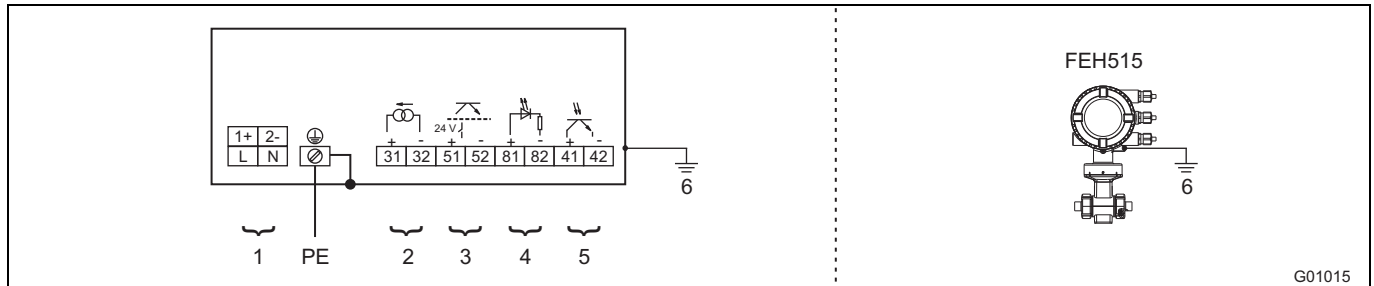

Fig. 18

A Transmitter

B Flowmeter sensor

1 Supply power:

See name plate

2 Current output (terminals 31/32)

Depending on the design, either an "active" or "passive" output will be available.

For devices designed for use in Ex Zone 1, the current output cannot be reconfigured locally.

- Active: 4 ... 20 mA, HART protocol (standard), load: $250 \Omega \leq R \leq 300 \Omega$
- Passive: 4 ... 20 mA, HART protocol (standard), load: $250 \Omega \leq R \leq 650 \Omega$, Supply voltage for the current output: min. 11 V, max. 30 V at terminals 31/32.

3 Digital output DO1 (terminal 51/52)

The output is always a "passive" output (optocoupler).

- Data for the optocoupler: $U_{\max} = 30 \text{ V}$, $I_{\max} = 220 \text{ mA}$, Function can be configured locally as "Pulse Output" or "Digital Output" using software. Factory setting is "Pulse Output".
- Configuration as pulse output Max. pulse frequency: 5250 Hz, pulse width: 0.1 ... 2.000 ms. The pulse factor and pulse width are interdependent and are calculated dynamically.
- Configuration as contact output. Function: System alarm, empty pipe alarm, max./min. alarm, flow direction signaling, other

4 Digital input: (Terminal 81/82)

Only available in combination with "passive" current output.

Function can be configured locally using software: External output switch-off, external totalizer reset, external totalizer stop, other Data for the optocoupler: $16 \text{ V} \leq U \leq 30 \text{ V}$, $R_i = 2 \text{ k}\Omega$

5 Digital output DO2 (terminal 41/42)

The output is always a "passive" output (optocoupler).

Data for the optocoupler: $U_{\max} = 30 \text{ V}$, $I_{\max} = 220 \text{ mA}$

Function can be configured locally as "Pulse Output" or "Digital Output" using software. Factory setting is "Digital Output", flow direction signaling.

6 Potential equalization PA

All inputs and outputs are electrically isolated from each other and from the supply power.

The electrical specifications are operating values.

5.2.2 Model FEH515 in Zone 1 / Div. 1 with PROFIBUS PA or FOUNDATION fieldbus

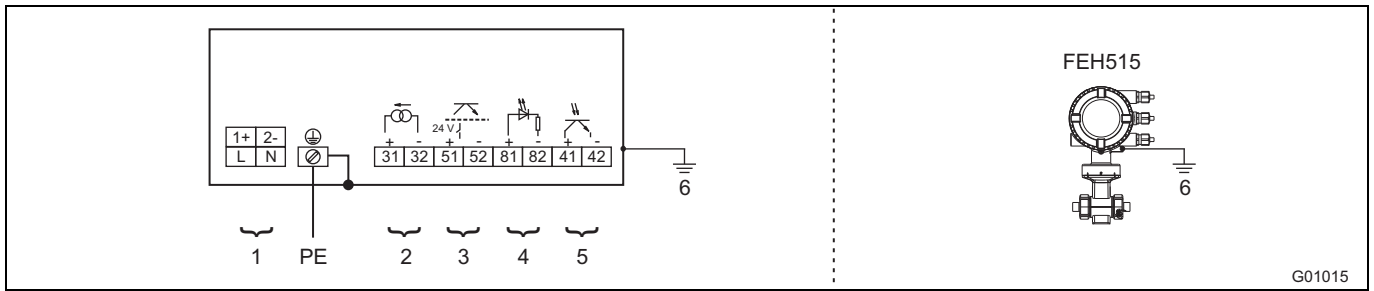

Fig. 19

- | | |
|--|---|
| <p>A Transmitter</p> <p>B Flowmeter sensor</p> <p>1 Supply power:
See name plate</p> <p>2 Digital communication (terminal 97 / 98)</p> <ul style="list-style-type: none"> • PROFIBUS PA in acc. with IEC 61158-2 (PA+ / PA-)
U = 9 ... 32 v, I = 10 mA (normal operation), I = 13 mA (in the event of an error)
Bus connection with integrated protection against polarity reversal
The bus address can be set via the DIP switches in the device (with dual-compartment transmitter housing only), the transmitter display or the fieldbus. <p>or</p> <ul style="list-style-type: none"> • FOUNDATION fieldbus in acc. with IEC 61158-2 (FF+ / FF-)
U = 9 ... 32 v, I = 10 mA (normal operation), I = 13 mA (in the event of an error / FDE)
Bus connection with integrated protection against polarity reversal <p>3 Not assigned</p> <p>4 Not assigned</p> | <p>5 Digital output DO2 (terminal 41 / 42)
The output is always a "passive" output (optocoupler).
Data for the optocoupler: $U_{max} = 30\text{ V}$, $I_{max} = 220\text{ mA}$
Function can be configured locally as "Pulse Output" or "Digital Output" using software. Factory setting is "Digital Output", flow direction signaling.</p> <p>6 Equipotential bonding</p> <p>7 Brown</p> <p>8 Red</p> <p>9 Orange</p> <p>10 Yellow</p> <p>11 Green</p> <p>12 Blue</p> <p>13 Violet</p> |
|--|---|

All inputs and outputs are electrically isolated from each other and from the supply power.

The electrical specifications given are operating values.

For devices with PROFIBUS PA or FOUNDATION fieldbus the bus termination must conform to the FISCO model or the explosion protection regulations, respectively.

5.3 Electrical data for operation in zones 1, 21, 22 / Div. 1

5.3.1 Devices with HART protocol

When operating in potentially explosive areas, observe the following electrical data for the signal inputs and outputs of the transmitter. For the correct current output design (active/passive), see the marking contained in the device's terminal box.

Model: FEH515

Inputs and outputs	Operating values		Ex data Explosion protection type Ex i, IS					
	U _N [V]	I _N [mA]	U _O [V]	I _O [mA]	P _O [mW]	C _O [nF]	C _{OPA} [nF]	L _O [mH]
Active current output Terminal 31 / 32	30	30	20	100	500	210	195	6
			U _I [V]	I _I [mA]	P _I [mW]	C _I [nF]	C _{I PA} [nF]	L _I [mH]
			60	425 ⁴⁾	2000 ⁴⁾	8,4	24	0,065
Passive current output Terminal 31 / 32	30	30	U _I [V]	I _I [mA]	P _I [mW]	C _I [nF]	C _{I PA} [nF]	L _I [nH]
			60	500 ⁴⁾	2000 ⁴⁾	8,4	24	170
Passive digital output DO2 Terminal 41 / 42	30	220	U _I [V]	I _I [mA]	P _I [mW]	C _I [nF]	C _{I PA} [nF]	L _I [nH]
			60	425 ^{1) 4)} 500 ^{2) 4)}	2000 ⁴⁾	3,6	3,6	170
Passive digital output DO1 Terminal 51 / 52	30	220	60	425 ^{1) 4)} 500 ^{2) 4)}	2000 ⁴⁾	3,6	3,6	170
Passive digital input DI ³⁾ Terminal 81/82	30	10	60	500 ⁴⁾	2000 ⁴⁾	3,6	3,6	170

1) For "active" current output

2) For "passive" current output

3) Only available in conjunction with passive current output

4) Intrinsically safe single-channel or multi-channel barriers (supply isolators) with resistance characteristic must be used.

All inputs and outputs are electrically isolated from each other and from the supply power.

Special connection conditions:

The output circuits are designed in such a way that they can be connected to both intrinsically-safe and non-intrinsically-safe circuits. It is not permitted to combine intrinsically safe and non-intrinsically safe circuits. In the case of intrinsically safe circuits, equipotential bonding is required.

The rated voltage of the non-intrinsically safe circuits is U_M = 60 V.

Provided that rated voltage U_M = 60 V is not exceeded if connections are established to non-intrinsically safe external circuits, intrinsic safety is still guaranteed.

5.3.2 Devices with PROFIBUS PA or FOUNDATION fieldbus

When operating in potentially explosive areas, observe the following electrical data for the signal inputs and outputs of the transmitter. For the correct design (PROFIBUS PA or FOUNDATION fieldbus), see the marking contained in the device's terminal box.

Model: FEH515

The fieldbus and the digital output can be connected in Zone 1 / Div. 1 in three different variants.

Variant 1 Intrinsically safe fieldbus connection in acc. with FISCO, intrinsically safe connection of the digital output

Inputs and outputs	Operating values		Ex data Explosion protection type Ex i, IS and FISCO					
	U_N [V]	I_N [mA]	U_i [V]	I_i [mA]	P_i [mW]	C_i [nF]	C_{IPA} [nF]	L_i [μH]
Passive digital output DO2 (Terminal 41 / 42)	30	220	60	200 ¹⁾	5000 ¹⁾	3,6	3,6	0,17
Fieldbus (Terminal 97 / 98)	32	30	17	380	5320	1	1	5

1) Intrinsically safe single-channel or multi-channel barriers (supply isolators) with resistance characteristic must be used.

Variant 2 Intrinsically safe fieldbus connection (not in acc. with FISCO!), intrinsically safe connection of the digital output

Inputs and outputs	Operating values		Ex data Explosion protection type Ex i, IS					
	U_N [V]	I_N [mA]	U_i [V]	I_i [mA]	P_i [mW]	C_i [nF]	C_{IPA} [nF]	L_i [μH]
Passive digital output DO2 (Terminal 41 / 42)	30	220	60	200 ¹⁾	5000 ¹⁾	3,6	3,6	0,17
Fieldbus (Terminal 97 / 98)	32	30	60	500	5000	1	1	5

1) Intrinsically safe single-channel or multi-channel barriers (supply isolators) with resistance characteristic must be used.

Variant 3 Fieldbus connection in acc. with FNICO (Zone 2, Div. 2), connection of digital output (Zone 2, Div. 2)

Inputs and outputs	Operating values		Ex data Explosion protection type Ex n, NI and FNICO					
	U_N [V]	I_N [mA]	U_i [V]	I_i [mA]	P_i [mW]	C_i [nF]	C_{IPA} [nF]	L_i [μH]
Passive digital output DO2 (Terminal 41 / 42)	30	220	-	-	-	-	-	-
Fieldbus (Terminal 97 / 98)	32	30	60	500 ¹⁾	5000 ¹⁾	1	1	5

1) Single-channel or multi-channel barriers (supply isolators) with resistance characteristic must be used.

All inputs and outputs are electrically isolated from each other and from the supply power.

Special connection conditions:

The output circuits are designed in such a way that they can be connected to both intrinsically-safe and non-intrinsically-safe circuits. It is not permitted to combine intrinsically safe and non-intrinsically safe circuits. In the case of intrinsically safe circuits, potential equalization is required.

The rated voltage of the non-intrinsically safe circuits is $U_M = 60$ V. Provided that rated voltage $U_M = 60$ V is not exceeded if connections are established to non-intrinsically safe external circuits, intrinsic safety is still given.

5.4 Temperature data

Model name	Surface temperature
FEH515	70 °C (158 °F)

The surface temperature depends on the fluid temperature.

With increasing fluid temperature > 70 °C (158 °F) the surface temperature also increases to the level of the fluid temperature.



Important (Note)

The maximum permissible fluid temperature depends on the lining and flange material, and is limited by the operating values in Table 1 and the explosion protection specifications in Tables 2 ... n.

Table 1: Fluid temperature as a function of lining and flange material

Model FEH515

Lining	Process connection	Material	Fluid temperature (operating values)	
			Minimum	Maximum
PFA	Flange	Stainless steel	-25 °C (-13 °F)	180 °C (356 °F)
PFA	Wafer type	-	-25 °C (-13 °F)	130 °C (266 °F)
PFA	Variable process connection	Stainless steel	-25 °C (-13 °F)	130 °C (266 °F)

Table 4: Fluid temperature (Ex data) for HygienicMaster Model FEH515

Nominal diameter	Design	Temperature class	Ambient temperature											
			(- 40 °C) ¹⁾ - 20 °C ... + 40 °C				(- 40 °C) ¹⁾ - 20 °C ... + 50 °C				(- 40 °C) ¹⁾ - 20 °C ... + 60 °C			
			Not thermally insulated		Thermally insulated		Not thermally insulated		Thermally insulated		Not thermally insulated		Thermally insulated	
			Gas	Gas & dust	Gas	Gas & dust	Gas	Gas & dust	Gas	Gas & dust	Gas	Gas & dust	Gas	Gas & dust
DN 3 ... DN 100	NT	T1	130 °C								110 °C	20 °C	80 °C	40 °C
	HT		180 °C								120 °C	20 °C	120 °C	20 °C
	NT	T2	130 °C								110 °C	20 °C	80 °C	40 °C
	HT		180 °C								120 °C	20 °C	120 °C	20 °C
	NT	T3	130 °C								110 °C	20 °C	80 °C	40 °C
	HT		180 °C								120 °C	20 °C	120 °C	20 °C
	NT	T4	120 °C								110 °C	20 °C	80 °C	40 °C
	HT		120 °C								120 °C	20 °C	120 °C	20 °C
	NT	T5	85 °C								85 °C	20 °C	80 °C	40 °C
	HT		85 °C								85 °C	20 °C	85 °C	20 °C
	NT	T6	70 °C								70 °C	20 °C	70 °C	40 °C
	HT		70 °C								70 °C	20 °C	70 °C	20 °C

1) Low-temperature version (option)

NT standard version, T_{medium} maximum 130 °C (266 °F).

HT high temperature version, T_{medium} maximum 180 °C (356 °F).

Not thermally insulated: The flowmeter sensor is not surrounded by pipe insulation material.

Thermally insulated: The flowmeter sensor is surrounded by pipe insulation material.



Important (Note)

The standard version includes explosion protection for gases and dust. Explosion protection for dust is only available for devices featuring a transmitter in a dual-compartment housing.

- If the installation location for the device is classified as a potentially explosive area for gases and dust, the temperature data in the "Gas & dust" columns in the table must be taken into consideration.
- If the installation location for the device is classified as a potentially explosive area for gases only, the temperature data in the "Gas" column in the table must be taken into consideration.

5.5 Special features of version designed for operation in Ex zone 1 / Div. 1

5.5.1 Configuring the current output

For devices designed for use in Ex Zone 1 / Div.1, the current output cannot be reconfigured subsequently.

The configuration required for the current output (active/passive) must be specified when the order is placed.

For the correct current output design (active/passive), see the marking contained in the device's terminal box.

5.5.2 Configuration of the digital outputs

For version designed for operation in Ex zone 1 / Div. 1, the digital outputs DO1 (51/52) and DO2 (41/42) can be configured on a NAMUR switching amplifier. On leaving the factory, the device is configured with the standard wiring (non-NAMUR).

Devices with PROFIBUS PA or FOUNDATION fieldbus only have the digital output DO2 (41 / 42).



Important (Note)

The outputs' type of protection remains unaffected by this. The devices connected to these outputs must conform to the applicable regulations for explosion protection.

The jumpers are located on the backplane in the transmitter housing.

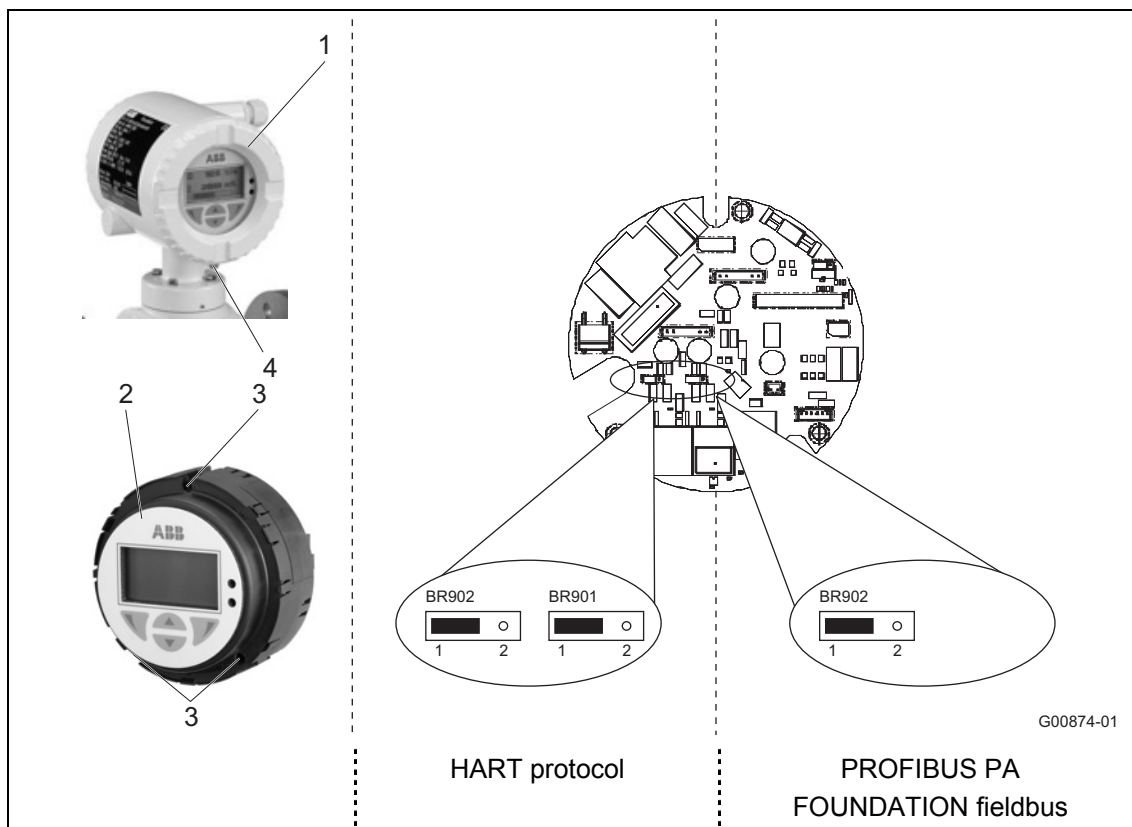

Fig. 20

BR902 for digital output DO1	BR901 for digital output DO2
BR902 in position 1: Standard (non-NAMUR) BR902 in position 2: NAMUR	BR901 in position 1: Standard (non-NAMUR) BR901 in position 2: NAMUR

Configure the digital outputs as described:

1. Switch off the supply power and wait at least 20 minutes before the next step.
2. Open the cover safety device (4) and housing cover (1).
3. Loosen screws (3) and pull out transmitter plug-in (2).
4. Insert the jumpers in the required positions.
5. Put the transmitter plug-in (2) back into the housing and retighten the screws (3).
6. Close the housing cover (1) and lock the cover by unscrewing the screw (4).

6 Ex-relevant specifications for operation in zones 2, 21, 22 / Div. 2

6.1 General

Devices with dual-compartment transmitter housing (model names FEH515 and FEH525) are approved for operation in the following potentially explosive areas:

- ATEX / IECEx Zone 2, 21, 22
- FM Div. 2
- cFM Div 2



Important (Note)

For detailed information on the individual approvals, refer to Section 1 „HygienicMaster 500 - Overview of technology“.

A temperature of 70 °C (158 °F) at the cable entry is assumed for the Ex calculations. Therefore, the cables used for the supply power and the signal inputs and outputs must have a minimum specification of 70 °C (158 °F).

For devices with remote mount design for use in FM / cFM Div. 1 or FM / cFM Div. 2 the signal cable between the flowmeter sensor and the transmitter must have a minimum length of 5 m (16.4 ft).

6.2 Electrical connection

6.2.1 Model FEH515, FET525 in Zone 2 / Div. 2, 2, FET521 outside the hazardous area with HART protocol

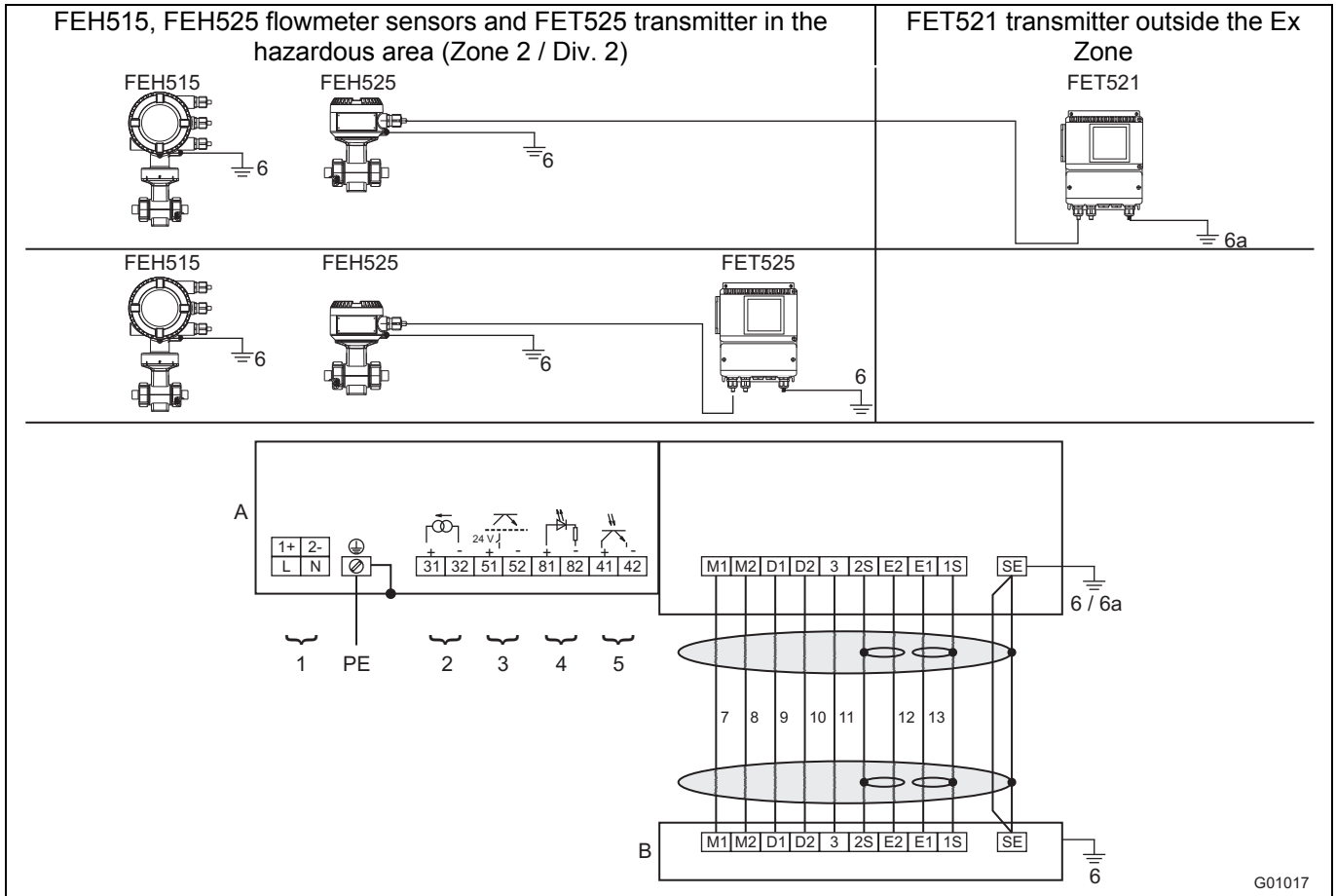

Fig. 21

A Transmitter
 B Flowmeter sensor

- 1 **Supply power:**
See name plate
- 2 **Current output (terminals 31 / 32)**
The current output can be configured locally as an "active" or "passive" output.
 - Active: 4 ... 20 mA, HART protocol (standard), load: $250 \Omega \leq R \leq 650 \Omega$
 - Passive: 4 ... 20 mA, HART protocol (standard), load: $250 \Omega \leq R \leq 650 \Omega$
 Supply voltage for the current output: minimum 11 V, maximum 30 V at terminals 31 / 32.
- 3 **Digital output DO1 (terminal 51 / 52)**
The digital output can be configured locally as an "active" or "passive" output (in the case of the transmitter with the dual-compartment housing, the output is configured using the software; in the case of the transmitter with the single-compartment housing, it is configured by means of jumpers on the transmitter backplane).
 - Active: $U = 19 \dots 21 \text{ V}$, $I_{\text{max}} = 220 \text{ mA}$, $f_{\text{max}} \leq 5250 \text{ Hz}$
 - Passive: $U_{\text{max}} = 30 \text{ V}$, $I_{\text{max}} = 220 \text{ mA}$, $f_{\text{max}} \leq 5250 \text{ Hz}$
 Function can be configured locally as "Pulse Output" or "Digital Output" using software. Factory setting is "Pulse Output".
 - Configuration as pulse output. Maximum pulse frequency: 5250 Hz, pulse width: 0.1 ... 2000 ms. The pulse factor and pulse width are interdependent and are calculated dynamically.
 - Configuration as contact output. Function: System alarm, empty pipe alarm, max. / min. alarm, flow direction signaling, other

- 4 **Digital input: (terminal 81 / 82)**
Function can be configured locally using software: External output switch-off, external totalizer reset, external totalizer stop, other
Data for the optocoupler: $16 \text{ V} \leq U \leq 30 \text{ V}$, $R_i = 2 \text{ k}\Omega$
- 5 **Digital output DO2 (terminal 41 / 42)**
The output is always a "passive" output (optocoupler).
Data for the optocoupler: $U_{\text{max}} = 30 \text{ V}$, $I_{\text{max}} = 220 \text{ mA}$, $f_{\text{max}} \leq 5250 \text{ Hz}$
Function can be configured locally as "Pulse Output" or "Digital Output" using software. Factory setting is "Digital Output", flow direction signaling.
- 6 **Equipotential bonding**
- 6a **Functional ground** (only with transmitter FET321 outside the hazardous area)
- 7 Brown
- 8 red
- 9 Orange
- 10 yellow
- 11 Green
- 12 blue
- 13 Violet

All inputs and outputs are electrically isolated from each other and from the supply power. The electrical specifications given are operating values.

6.2.2 Model FEH515, FET525 in Zone 2 / Div. 2, FET521 outside the hazardous area with PROFIBUS PA or FOUNDATION fieldbus

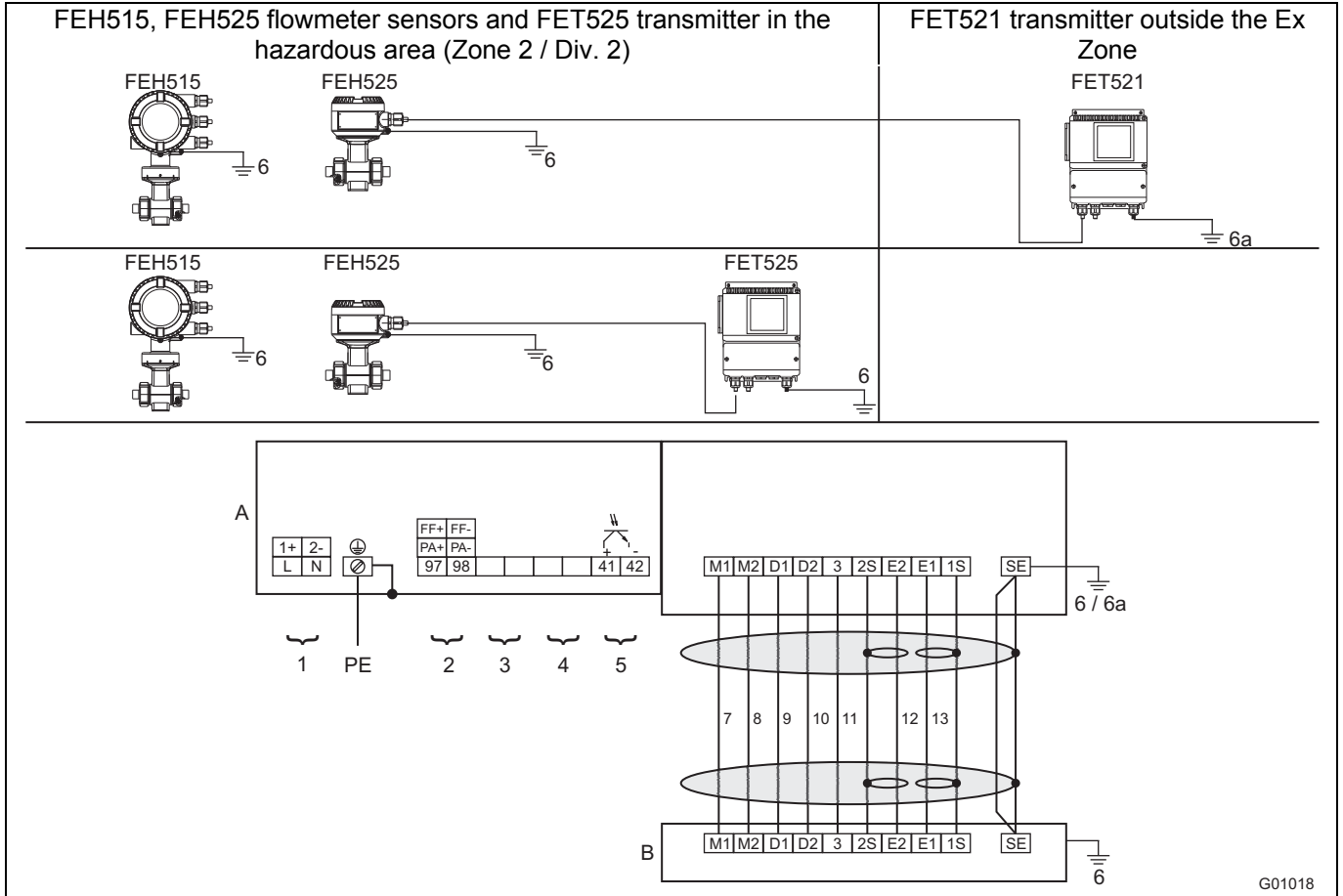

Fig. 22

A Transmitter
B Flowmeter sensor

- 1 **Supply power:**
See name plate
- 2 **Digital communication (terminal 97 / 98)**
 - **PROFIBUS PA in acc. with IEC 61158-2 (PA+ / PA-)**
U = 9 ... 32 v, I = 10 mA (normal operation), I = 13 mA (in the event of an error)
Bus connection with integrated protection against polarity reversal
The bus address can be set via the DIP switches in the device (with dual-compartment transmitter housing only), the transmitter display or the fieldbus.
- or
- **FOUNDATION fieldbus in acc. with IEC 61158-2 (FF+ / FF-)**
U = 9 ... 32 v, I = 10 mA (normal operation), I = 13 mA (in the event of an error / FDE)
Bus connection with integrated protection against polarity reversal
- 3 **Not assigned**
- 4 **Not assigned**

- 5 **Digital output DO2 (terminal 41 / 42)**
The output is always a "passive" output (optocoupler).
Data for the optocoupler: $U_{max} = 30\text{ V}$, $I_{max} = 220\text{ mA}$,
 $f_{max} \leq 5250\text{ Hz}$,
Function can be configured locally as "Pulse Output" or "Digital Output" using software. Factory setting is "Digital Output", flow direction signaling.
- 6 **Equipotential bonding**
- 6a **Functional ground** (only with flowmeter sensor FET321 outside the hazardous area)
- 7 Brown
- 8 red
- 9 Orange
- 10 yellow
- 11 Green
- 12 blue
- 13 Violet

All inputs and outputs are electrically isolated from each other and from the supply power.

The electrical specifications given are operating values.

For devices with PROFIBUS PA or FOUNDATION fieldbus in Zone 2 / Div 2 the bus termination must conform to the FNICO model or the explosion protection regulations, respectively.

6.3 Electrical data for operation in zones 2, 21, 22 / Div. 2

6.3.1 Devices with HART protocol

When operating in potentially explosive areas, observe the following electrical data for the signal inputs and outputs of the transmitter. For the correct current output design (active/passive), see the marking contained in the device's terminal box.

Model: FEH515, FET525

Signal inputs and outputs	Ex data		Operating values	
	Ex n/NI			
	U _i [V]	I _i [mA]	U _i [V]	I _i [mA]
Current output Active/passive Terminal 31/32	30	30	30	30
Digital output DO1 Active/passive Terminal 51/52	30	220	30	220
Digital output DO2 passive Terminal 41/42	30	220	30	220
Digital input DI Terminal 81/82	30	10	30	10

All inputs and outputs are electrically isolated from each other and from the supply power.

6.3.2 Devices with PROFIBUS PA or FOUNDATION fieldbus

When operating in potentially explosive areas, observe the following electrical data for the signal inputs and outputs of the transmitter. For the correct design (PROFIBUS PA or FOUNDATION fieldbus), see the marking contained in the device's terminal box.

Model: FEH515, FET525

Inputs and outputs	Operating values		Ex data					
	U _N [V]	I _N [mA]	Explosion protection type Ex n, NI and FNICO					
	U _i [V]	I _i [mA]	P _i [mW]	C _i [nF]	C _{iPA} [nF]	L _i [μH]		
Passive digital output DO2 Terminal 41/42	30	220	-	-	-	-	-	-
Fieldbus Terminal 97/98	32	30	32	500 ¹⁾	7000 ¹⁾	1	1	5

1) Single-channel or multi-channel barriers (supply isolators) with resistance characteristic must be used.

6.4 Temperature data

Model name	Surface temperature
FEH515	70 °C (158 °F)
FEH525	85 °C (185 °F)
FET525	70 °C (158 °F)

The surface temperature depends on the fluid temperature.

With increasing fluid temperature > 70 °C (> 158 °F) or > 85 °C (> 185 °F) the surface temperature also increases to the level of the fluid temperature.

Table 1: Fluid temperature as a function of lining and flange material

Model FEH515, FEH525

Lining	Process connection	Material	Fluid temperature (operating values)	
			Minimum	Maximum
PFA	Flange	Stainless steel	-25 °C (-13 °F)	180 °C (356 °F)
PFA	Wafer type	-	-25 °C (-13 °F)	130 °C (266 °F)
PFA	Variable process connection	Stainless steel	-25 °C (-13 °F)	130 °C (266 °F)

Table 2: Fluid temperature (Ex data) for HygienicMaster Model FEH515

Nominal diameter	Design	Temperature class	Ambient temperature											
			- 20 °C ... + 40 °C				- 20 °C ... + 50 °C				- 20 °C ... + 60 °C			
			- 40 °C ... + 40 °C ¹⁾				- 40 °C ... + 50 °C ¹⁾				- 40 °C ... + 60 °C ¹⁾			
			Not thermally insulated		Thermally insulated		Not thermally insulated		Thermally insulated		Not thermally insulated		Thermally insulated	
Gas	Gas & dust	Gas	Gas & dust	Gas	Gas & dust	Gas	Gas & dust	Gas	Gas & dust	Gas	Gas & dust			
ProcessMaster DN 3 ... DN 2000 HygienicMaster DN 3 ... DN 100	NT	T1	130 °C	130 °C	---	---	130 °C	100 °C ²⁾ 110 °C ³⁾	---	---	80 °C	40 °C	---	---
	HT		180 °C	180 °C	180 °C	180 °C	180 °C	180 °C	180 °C	180 °C	180 °C	40 °C	180 °C	40 °C
	NT	T2	130 °C	130 °C	---	---	130 °C	100 °C ²⁾ 110 °C ³⁾	---	---	80 °C	40 °C	---	---
	HT		180 °C	180 °C	180 °C	180 °C	180 °C	180 °C	180 °C	180 °C	180 °C	40 °C	180 °C	40 °C
	NT	T3	130 °C	130 °C	---	---	130 °C	100 °C ²⁾ 110 °C ³⁾	---	---	80 °C	40 °C	---	---
	HT		180 °C	180 °C	180 °C	180 °C	180 °C	180 °C	180 °C	180 °C	180 °C	40 °C	180 °C	40 °C
	NT	T4	130 °C	130 °C	---	---	130 °C	100 °C ²⁾ 110 °C ³⁾	---	---	80 °C	40 °C	---	---
	HT		130 °C	130 °C	130 °C	130 °C	130 °C	130 °C	130 °C	130 °C	130 °C	40 °C	130 °C	40 °C

1) Low-temperature version (option)

2) Temperature values for ProcessMaster

3) Temperature values for HygienicMaster

NT: standard sensor design, T_{medium} maximum 130 °C (266 °F)HAT: high-temperature sensor design, T_{medium} maximum 180 °C (356 °F)

Not thermally insulated: The flowmeter sensor is not surrounded by pipe insulation material.

Thermally insulated: The flowmeter sensor is surrounded by pipe insulation material.

**Important (Note)**

The standard version includes explosion protection for gases and dust. Explosion protection for dust is only available for devices featuring a transmitter in a dual-compartment housing.

- If the installation location for the device is classified as a potentially explosive area for gases and dust, the temperature data in the "Gas & dust" columns in the table must be taken into consideration.
- If the installation location for the device is classified as a potentially explosive area for gases only, the temperature data in the "Gas" column in the table must be taken into consideration.

Table 3: Fluid temperature (Ex data) for HygienicMaster Model FEH525

Nominal diameter	Design	Temperature class	Ambient temperature											
			- 20 °C ... + 40 °C				- 20 °C ... + 50 °C				- 20 °C ... + 60 °C			
			- 40 °C ... + 40 °C ¹⁾				- 40 °C ... + 50 °C ¹⁾				- 40 °C ... + 60 °C ¹⁾			
			Not thermally insulated		Thermally insulated		Not thermally insulated		Thermally insulated		Not thermally insulated		Thermally insulated	
			Gas	Gas & dust	Gas	Gas & dust	Gas	Gas & dust	Gas	Gas & dust	Gas	Gas & dust	Gas	Gas & dust
ProcessMaster DN 3 ... DN 2000 HygienicMaster DN 3 ... DN 100	NT	T1	130 °C	130 °C	---	---	130 °C	130 °C	---	---	110 °C ²⁾ 120 °C ³⁾	110 °C	---	---
	HT	T1	180 °C	180 °C	180 °C	180 °C	180 °C	180 °C	180 °C	180 °C	180 °C	180 °C	180 °C	180 °C
	NT	T2	130 °C	130 °C	---	---	130 °C	130 °C	---	---	110 °C ²⁾ 120 °C ³⁾	110 °C	---	---
	HT	T2	180 °C	180 °C	180 °C	180 °C	180 °C	180 °C	180 °C	180 °C	180 °C	180 °C	180 °C	180 °C
	NT	T3	130 °C	130 °C	---	---	130 °C	130 °C	---	---	110 °C ²⁾ 120 °C ³⁾	110 °C	---	---
	HT	T3	180 °C	180 °C	180 °C	180 °C	180 °C	180 °C	180 °C	180 °C	180 °C	180 °C	180 °C	180 °C
	NT	T4	130 °C	130 °C	---	---	130 °C	130 °C	---	---	110 °C ²⁾ 120 °C ³⁾	110 °C	---	---
	HT	T4	130 °C	130 °C	130 °C	130 °C	130 °C	130 °C	130 °C	130 °C	130 °C	130 °C	130 °C	130 °C
	NT	T5	95 °C	95 °C	---	---	95 °C	95 °C	---	---	95 °C	95 °C	---	---
	HT	T5	95 °C	95 °C	95 °C	95 °C	95 °C	95 °C	95 °C	95 °C	95 °C	95 °C	95 °C	95 °C
	NT	T6	80 °C	80 °C	---	---	80 °C	80 °C	---	---	80 °C	80 °C	---	---
	HT	T6	80 °C	80 °C	80 °C	80 °C	80 °C	80 °C	80 °C	80 °C	80 °C	80 °C	80 °C	80 °C

1) Low-temperature version (option)

2) Temperature values for ProcessMaster

3) Temperature values for HygienicMaster

NT: standard sensor design, T_{medium} maximum 130 °C (266 °F)HT: high-temperature sensor design, T_{medium} maximum 180 °C (356 °F)

Not thermally insulated: The flowmeter sensor is not surrounded by pipe insulation material.

Thermally insulated: The flowmeter sensor is surrounded by pipe insulation material.

**Important (Note)**

The standard version includes explosion protection for gases and dust.

- If the installation location for the device is classified as a potentially explosive area for gases and dust, the temperature data in the "Gas & dust" columns in the table must be taken into consideration.
- If the installation location for the device is classified as a potentially explosive area for gases only, the temperature data in the "Gas" columns in the table must be taken into consideration.

7 Explosion protection specifications for operation in areas with combustible dust

7.1 Information about using the device in areas with combustible dust

The device with dual-compartment transmitter housing is approved for use in potentially explosive areas (gas and dust).

The Ex certification is provided on the name plate.



DANGER - Risk of explosion!

The dust explosion protection is also provided by the housing.

Modifications to the housing are not allowed (e.g., removing or omitting parts).

7.1.1 Maximum Allowable Surface Temperature

Model name	Maximum surface temperature
FEH525	T 85 °C (185 °F) ... T _{medium}
FEH515	T 70 °C (158 °F) ... T _{medium}
FET525	T 70 °C (158 °F)

The maximum surface temperature is applicable to dust layers of up to 5 mm (0.20 inch) in thickness. The minimum permissible ignition and smoldering temperatures of the dust atmosphere should be calculated in accordance with IEC61241ff.

With thicker dust layers, the maximum permissible surface temperature must be reduced. The dust can be conductive or non-conductive. IEC61241ff must be observed.

7.1.2 Minimum signal cable length

In explosion protection areas, the signal cable cannot be shorter than 5 m (16.4 ft).

8 Installation requirements

8.1.1 Grounding

The flowmeter sensor must be connected to ground potential. For technical reasons, this potential should be identical to the potential of the metering fluid.

For plastic or insulated lined pipelines, the fluid is grounded by installing ground plates. When there are stray potentials present in the pipeline, a ground plate is recommended on both ends of the meter sensor.

8.2 Mounting

The following points must be observed for the installation:

- The meter tube must always be completely full.
- The flow direction must correspond to the identification if present.
- The maximum torque for all flange connections must be complied with. The max torque depends on the temperature, pressure, material of the flange bolts and gaskets and has to be chosen accordingly.
- The devices must be installed without mechanical tension (torsion, bending).
- Flowmeters with coplanar counter flanges may only be installed with suitable seals.
- Use flange seals made from a compatible material for the fluid and fluid temperatures.
- Seals must not extend into the flow area since possible turbulence could influence the device accuracy.
- The pipeline may not exert any unallowable forces and torques on the device.
- Do not remove the plugs in the cable connectors until you are ready to install the electrical cable.
- Install the separate converter at a largely vibration-free location.
- Do not expose the converter to direct sunlight or provide for appropriate sun protection where necessary.

8.2.1 Flow direction

The device measures the flowrate in both directions. Forward flow is the factory setting, as shown in Fig. 23.

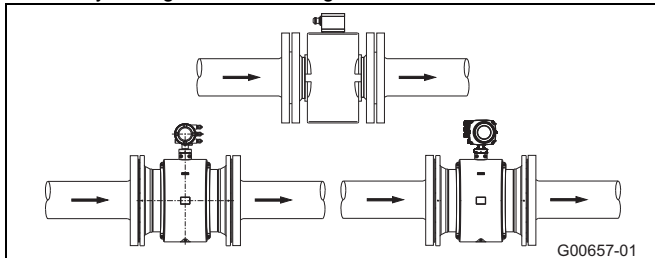

Fig. 23

8.2.2 Electrode axis

Electrode axis (1) should be horizontal if at all possible or no more than 45° from horizontal.

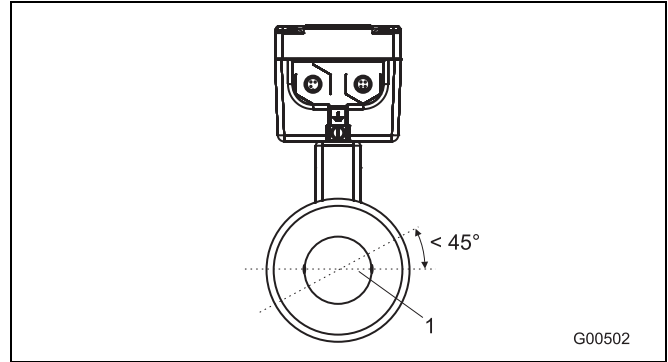

Fig. 24

8.2.3 In- and outlet pipe sections

The metering principle is independent of the flow profile as long as standing eddies do not extend into the metering section, such as may occur after double elbows (1), in the event of tangential inflow, or where half-open gate valves are located upstream of the flowmeter sensor.

In such cases, measures must be put in place to normalize the flow profile.

- Do not install fittings, manifolds, valves, etc., directly in front of the flowmeter sensor (1).
- Butterfly valves must be installed so that the valve plate does not extend into the flowmeter sensor.
- Valves or other turn-off components should be installed in the outlet pipe section (2).

Experience has shown that, in most installations, straight inlet sections 3 x DN long and straight outlet sections 2 x DN long are sufficient (DN = nominal diameter of the sensor Fig. 25).

For test stands, the reference conditions of 10 x DN straight inlet and 5 x DN straight outlet must be provided, in accordance with EN 29104 / ISO 9104.

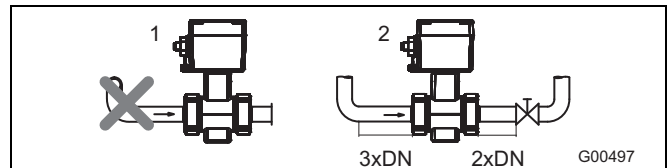

Fig. 25

8.2.4 Vertical connections

- Vertical installation for measurement of abrasive fluids, flow preferably from below to above.

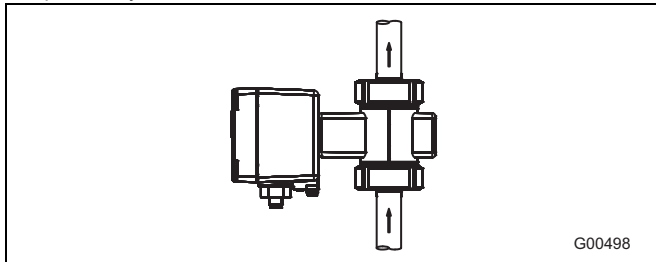

Fig. 26

8.2.5 Horizontal connections

- Meter tube must always be completely full.
- Provide for a slight incline of the connection for degassing.

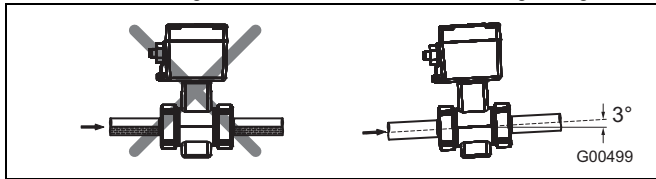

Fig. 27

8.2.6 Free inlet or outlet

- Do not install the flowmeter at the highest point or in the draining-off side of the pipeline, flowmeter runs empty, air bubbles can form (1).
- Provide for a siphon fluid intake for free inlets or outlets so that the pipeline is always full (2).

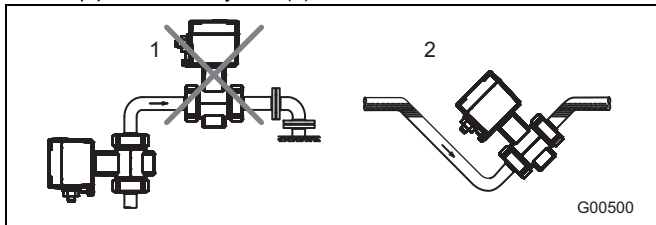

Fig. 28

8.2.7 Strongly contaminated fluids

- For strongly contaminated fluids, a bypass connection according to the figure is recommended so that operation of the system can continue to run without interruption during the mechanical cleaning.

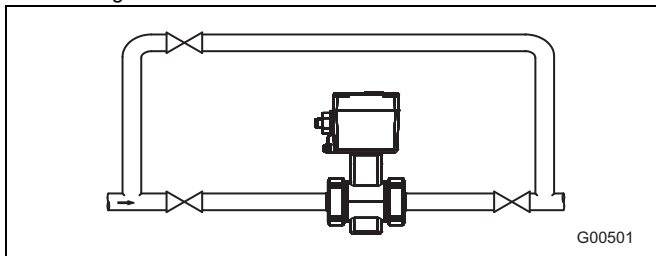

Fig. 29

8.2.8 Installation in the vicinity of pumps

- For flowmeter primaries which are to be installed in the vicinity of pumps or other vibration generating equipment, the utilization of mechanical snubbers is advantageous.

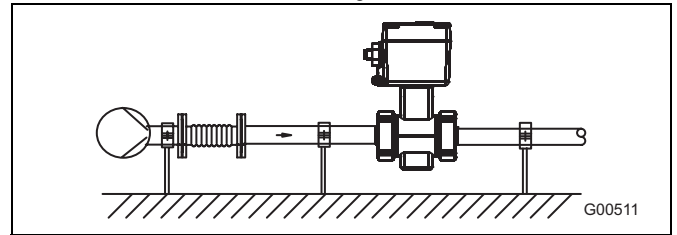

Fig. 30

8.2.9 Installation of the high temperature design

The high temperature design allows for complete thermal insulation of the sensor. The pipeline and sensor must be insulated after installing the unit according to the following illustration.

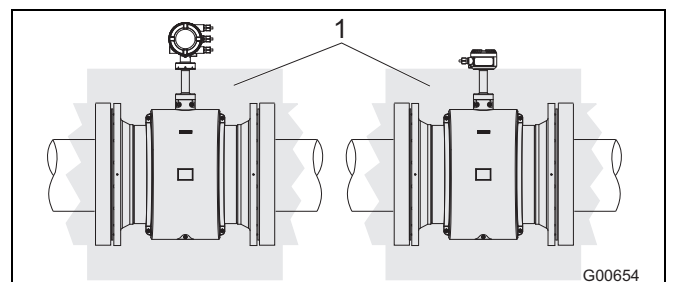

Fig. 31

1 Insulation

8.2.10 Devices with extended diagnostic functions

For devices with extended diagnostic functions different installation conditions may be valid. For further information read and observe chapter 3 "Extended diagnostic functions".

8.2.11 Installation in pipelines with larger nominal diameters

Determine the resulting pressure loss when using reduction pieces (1):

1. Calculate the diameter ratio d/D .
2. Determine the flow velocity based on the flow range nomograph (Fig. 33).
3. Read the pressure drop on the Y-axis in Fig. 33.

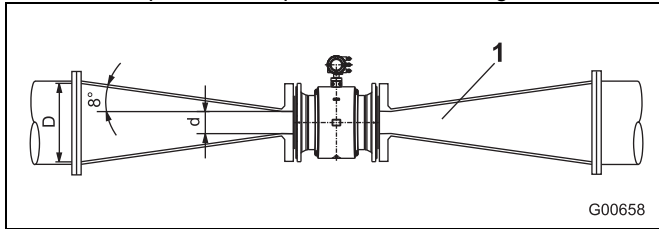

Fig. 32

- | | | | |
|---|----------------------------------|------------|---------------------------------|
| 1 | Flange transition piece | Δp | pressure loss [mbar] |
| d | Inside diameter of the flowmeter | D | Inside diameter of the pipeline |
| V | flow velocity [m/s] | | |

Nomograph for pressure drop calculations

For flange transition piece with $\alpha/2 = 8^\circ$

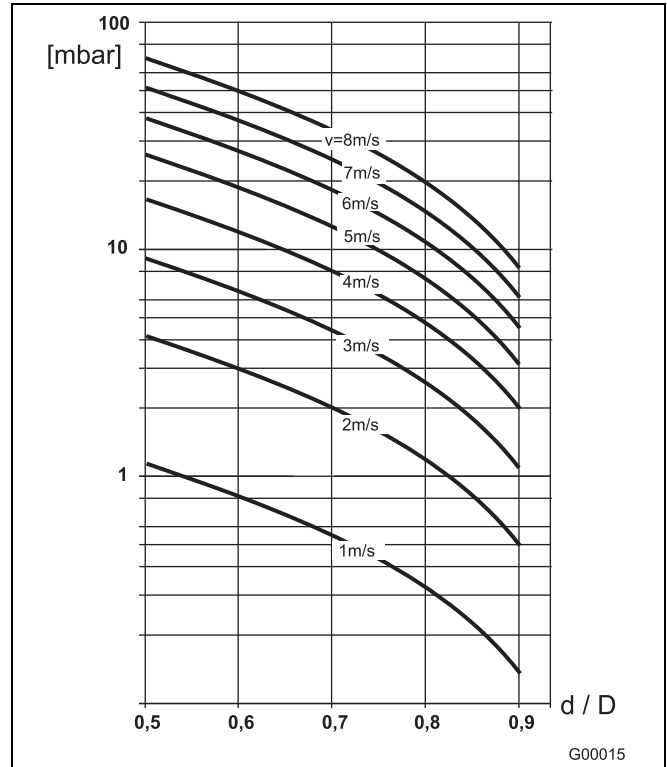

Fig. 33

9 Dimensions

9.1 Flange, DN 3 ... 40 (1/10 ... 1 1/2")

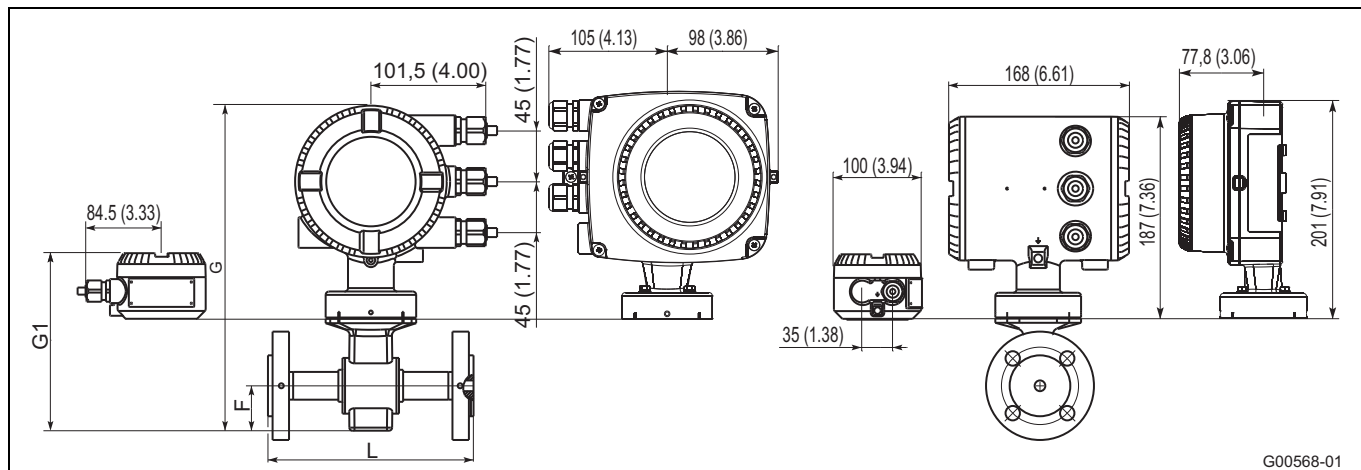

Fig. 34: Dimensions in mm (inch)

Flange in acc. with DIN/EN 1092-1 1)

Dimensions [mm (inch)]						Approx. weight [kg (lb)]	
DN	PN 2)	L 3)	G 4)	G1 4)	F	Compact design	Ext. Transmitter
3 ... 8 5)	10 ... 40	130 (5.12)	293 (11.54)	180 (7.09)	38.5 (1.52)	7 (15.43)	5 (11.02)
10	10 ... 40	200 (7.78)	293 (11.54)	180 (7.09)	38.5 (1.52)	7 (15.43)	5 (11.02)
15	10 ... 40	200 (7.78)	293 (11.54)	180 (7.09)	38.5 (1.52)	8 (17.64)	8 (17.64)
20	10 ... 40	200 (7.78)	302 (11.89)	190 (7.84)	43 (1.69)	8 (17.64)	8 (17.64)
25	10 ... 40	200 (7.78)	311 (12.24)	199 (7.83)	48 (1.89)	9 (19.84)	9 (19.84)
32	10 ... 40	200 (7.78)	321 (12.64)	208 (8.19)	53 (2.09)	11 (24.25)	11 (24.25)
40	10 ... 40	200 (7.78)	330 (12.99)	217 (8.54)	57 (2.24)	11 (24.25)	11 (24.25)

Tolerance L: +0 / -3 mm (+0 / -0.118 inch)

Flange in acc. with ASME B16.5

Dimensions [mm (inch)]						Approx. weight [kg (lb)]	
DN	Inch	L 3)	G 4)	G1 4)	F	Compact design	Ext. Transmitter
3 ... 8	1/8 ... 5/16 6)	130 (5.12)	293 (11.54)	180 (7.09)	38.5 (1.52)	7 (15.43)	5 (11.02)
10	3/8 6)	200 (7.78)	293 (11.54)	180 (7.09)	38.5 (1.52)	7 (15.43)	5 (11.02)
15	1/2	200 (7.78)	293 (11.54)	180 (7.09)	38.5 (1.52)	8 (17.64)	8 (17.64)
20	3/4	200 (7.78)	302 (11.89)	190 (7.84)	43 (1.69)	8 (17.64)	8 (17.64)
25	1	200 (7.78)	311 (12.24)	199 (7.83)	48 (1.89)	9 (19.84)	9 (19.84)
32	1 1/4	200 (7.78)	321 (12.64)	208 (8.19)	53 (2.09)	11 (24.25)	11 (24.25)
40	1 1/2	200 (7.78)	330 (12.99)	217 (8.54)	57 (2.24)	11 (24.25)	11 (24.25)

Tolerance L: +0 / -3 mm (+0 / -0.118 inch)

- 1) Connecting dimensions in acc. with EN 1092-1. For DN 65, PN 16 in acc. with EN 1092-1, please order PN 40.
- 2) Other pressure ratings available on request.
- 3) If grounding plates are installed (attached to both sides of the flange), this increases dimension L as follows: DN 3 ... 100 by 3 mm (0.118 inch).
- 4) Depending on the device design, the dimensions change according to the following table.

Device design	Dimension G	Dimension G1
Without explosion protection	Standard temperature design	0
	High temperature version	+127 mm (+5 inch)
Explosion protection Zone 1, Div. 1	Standard temperature design	+74 mm (+2.91 inch)
	High temperature version	+127 mm (+5 inch)
Explosion protection Zone 2, Div. 2	Standard temperature design	0
	High temperature version	+127 mm (+5 inch)

- 5) Connection flange DN 10.
- 6) Connection flange 1/2".

9.2 Flange, DN 50 ... 100 (2 ... 4")

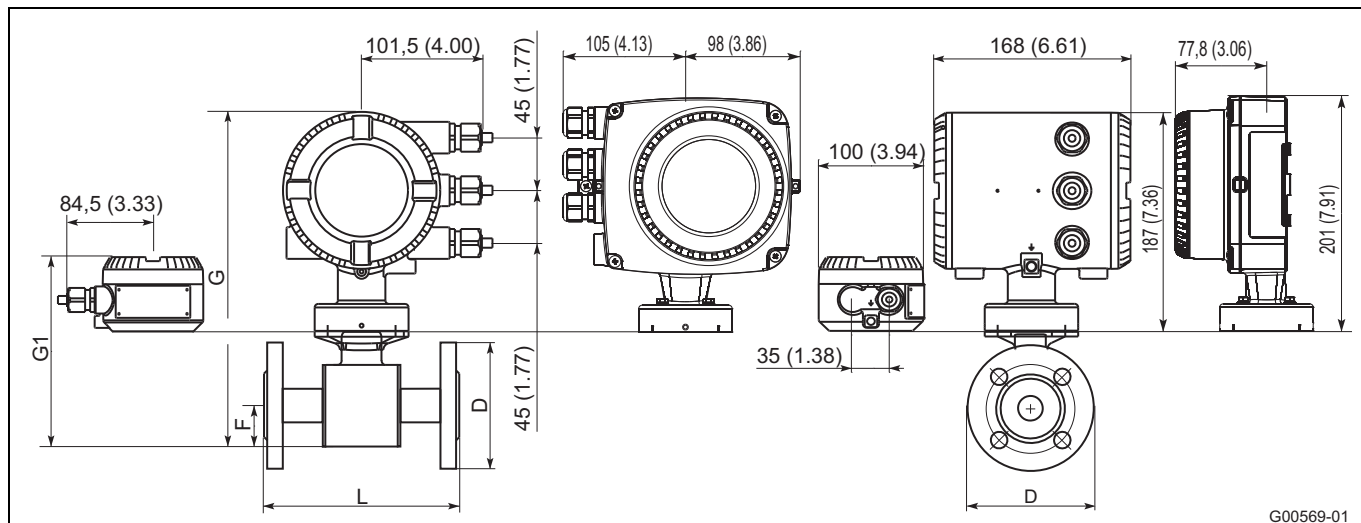

Fig. 35: Dimensions in mm (inch)

Flange in acc. with DIN/EN 1092-1

Dimensions [mm (inch)]							Approx. weight [kg (lb)]	
DN	PN 1)	D	L 2)	G 3)	G1 3)	F	Compact design	Ext. Transmitter
50	10 ... 40	165 (6.50)	200 (7.87)	332 (13.06)	213 (8.39)	50 (1.97)	13 (28.66)	11 (24.25)
65	10 ... 40	185 (7.28)	200 (7.87)	348 (13.7)	235 (9.26)	58 (2.28)	17 (37.48)	15 (33.07)
80	10 ... 40	200 (7.87)	200 (7.87)	365 (14.37)	252 (9.92)	66.5 (2.62)	20 (44.09)	18 (39.68)
100	16	220 (8.66)	250 (9.84)	392 (15.45)	280 (11.01)	80.2 (3.16)	23 (50.71)	21 (46.30)

Tolerance L: +0 / -3 mm, (+0 / -0.118 inch)

Flange in acc. with ASME B16.5

Dimensions [mm (inch)]								Approx. weight [kg (lb)]	
DN	Inch	CL150 D	CL300 D	ISO 13359 L 2)	G 3)	G1 3)	F	Compact design	Ext. Transmitter
50	2	153 (6.02)	165 (6.50)	200 (7.87)	332 (13.06)	213 (8.39)	50 (1.97)	13 (28.66)	11 (24.25)
65	2 1/2	178 (7.01)	191 (7.52)	200 (7.87)	348 (13.7)	235 (9.26)	58 (2.28)	17 (37.48)	15 (33.07)
80	3	191 (7.52)	210 (8.27)	200 (7.87)	365 (14.37)	252 (9.92)	66.5 (2.62)	20 (44.09)	18 (39.68)
100	4	229 (9.02)	254 (10)	250 (9.84)	392 (15.45)	280 (11.01)	80.2 (3.16)	23 (50.71)	21 (46.30)

Tolerance L: +0 / -3 mm, (+0 / -0.118 inch)

- 1) Other pressure ratings available on request.
- 2) If grounding plates are installed (attached to both sides of the flange), this increases dimension L by 3 mm (0.118 inch).
- 3) Depending on the device design, the dimensions change according to the following table.

Device design		Dimension G	Dimension G1
No ignition protection	Standard temperature design	0	0
	High temperature version	+127 mm (+5 inch)	+127 mm (+5 inch)
Explosion protection Zone 1, Div. 1	Standard temperature design	+74 mm (+2.91 inch)	Not available
	High temperature version	+127 mm (+5 inch)	Not available
Explosion protection Zone 2, Div. 2	Standard temperature design	0	0
	High temperature version	+127 mm (+5 inch)	+127 mm (+5 inch)

9.3 Wafer type, DN 3 ... 40 (1/10 ... 1 1/2")

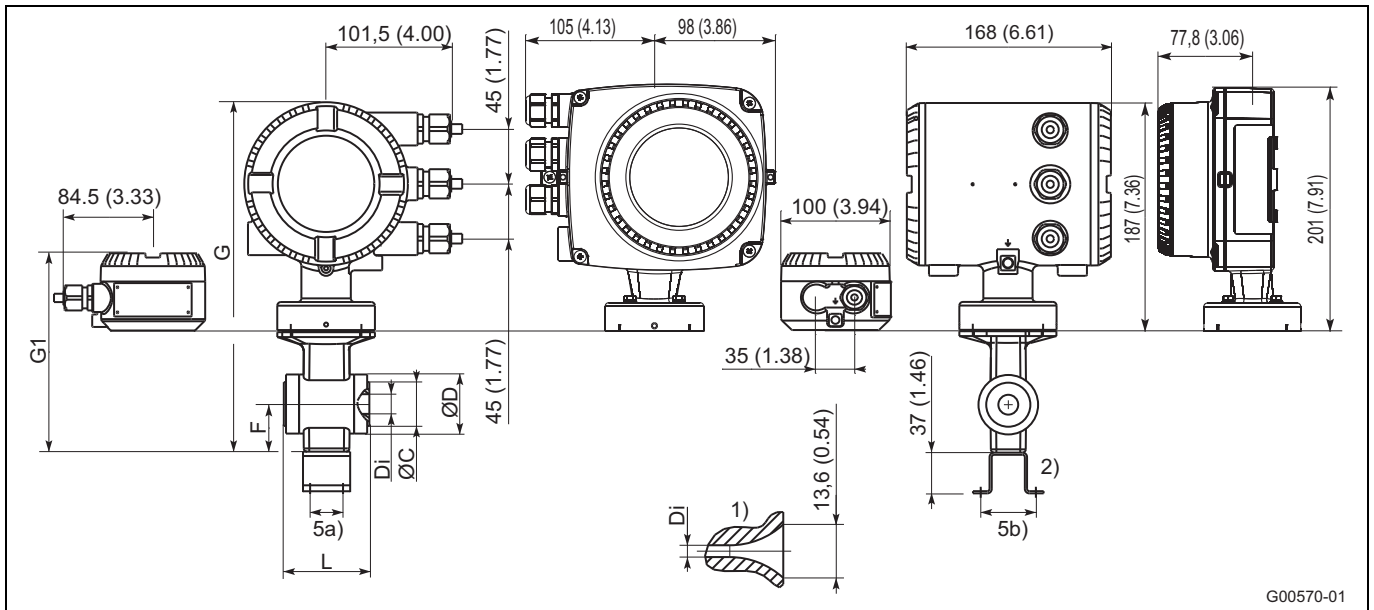

Fig. 36: Dimensions in mm (inch)

Dimensions [mm]									Approx. weight [kg]	
DN	PN	C	D	Di	F	G 4)	G1 4)	L 3)	Compact design	Ext. Transmitter
3 ... 8	10 ... 40	42	45	3 ... 8	38.5	293	180	68	3.5	1.5
10	10 ... 40	42	45	10	38.5	293	180	68	3.5	1.5
15	10 ... 40	42	45	13	38.5	293	180	68	3.5	1.5
20	10 ... 40	50	54	18	43	302	190	78	4	2
25	10 ... 40	59	63	24	48	311	199	90	4.5	2.5
32	10 ... 40	69	73	30	53	321	208	98	4.5	2.5
40	10 ... 40	77	82	36	57	330	217	103	5	3

Tolerance L: +0 / -3 mm (+0 / -0.118 inch)

Dimensions [inch]									Approx. weight [lb]		
DN	Inch	C	D	Di	F	G 4)	G1 4)	L 3)	Compact design	Ext. Transmitter	
3 ... 8	1/8 ... 5/16	CL150 / CL300	1.65	1.77	0.12 ... 0.31	1.5	11.5	7.1	2.7	7.72	3.31
10	3/8	CL150 / CL300	1.65	1.77	0.39	1.5	11.5	7.1	2.7	7.72	3.31
15	1/2	CL150 / CL300	1.65	1.77	0.51	1.5	11.5	7.1	2.7	7.72	3.31
20	3/4	CL150 / CL300	1.97	2.13	0.71	1.7	11.9	7.5	3.1	8.82	4.41
25	1	CL150 / CL300	2.32	2.48	0.94	1.9	12.2	7.8	3.5	9.92	5.51
32	1 1/4	CL150 / CL300	2.72	2.87	1.18	2.1	12.6	8.2	3.9	9.92	5.51
40	1 1/2	CL150 / CL300	3.03	3.23	1.42	2.2	13	8.5	4.1	11.02	6.61

Tolerance L: +0 / -3 mm (+0 / -0.118 inch)

- 1) Only with DN 3 ... 8.
- 2) Bracket (optional), not available for 3A approval.
- 3) If a grounding plate is installed (attached to one side of the flange), this increases dimension L by 3 mm (0.118 inch).
- 4) Depending on the device design, the dimensions change according to the following table.

Device design	Dimension G	Dimension G1
No ignition protection Standard temperature design	0	0
Explosion protection Zone 1, Div. 1 Standard temperature design	+74 mm (+2.91 inch)	Not available
Explosion protection Zone 2, Div. 2 Standard temperature design	0	0

5) Installation hole spacing for angle bracket as per the table below.

Nominal diameter	Installation hole spacing	
	5a)	5b)
DN 3 ... 20	28 mm (1.1 inch)	50 mm (1.97 inch)
DN 25 ... 40	46 mm (1.81 inch)	70 mm (2.76 inch)

9.4 Wafer type, DN 50 ... 100 (2 ... 4")

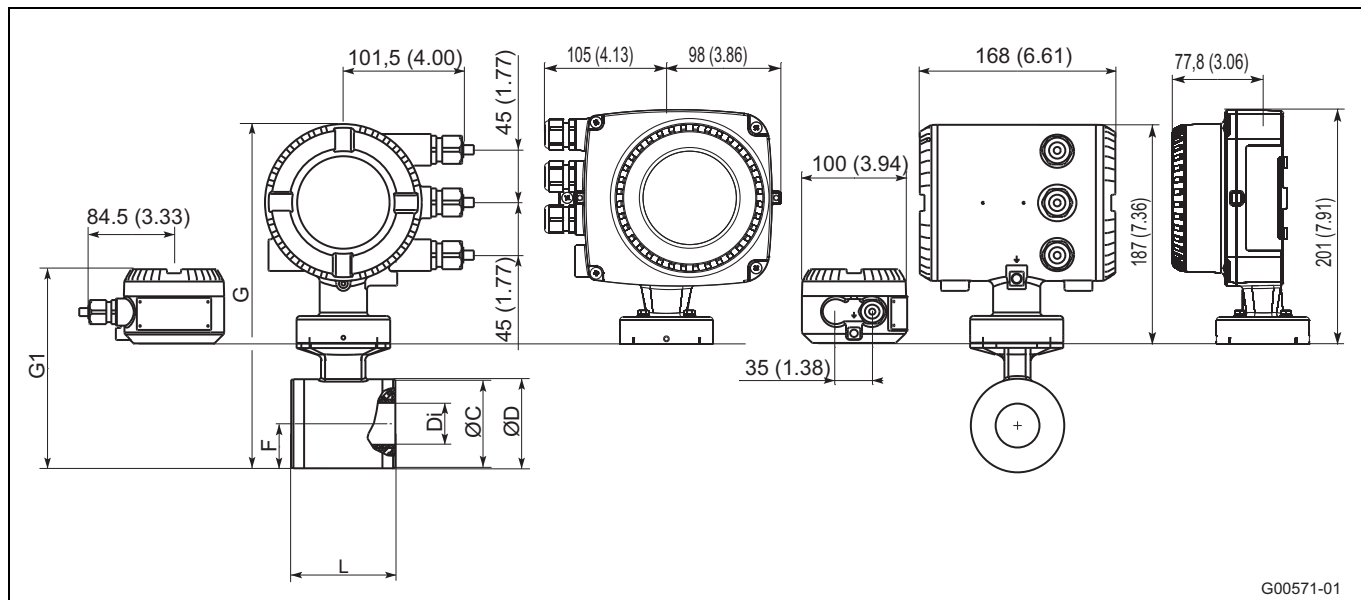

Fig. 37: Dimensions in mm (inch)

Dimensions [mm]										Approx. weight [kg]	
DN	PN	C	D	Di	F	G 2)	G1 2)	L 1) 3)	L 1) 4)	integral mount design	remote mount design
50	10 ... 40	95	100	47	50	332	213	117	117	6.5	4.5
65	16	111	116	62	58	348	235	103	200	7	5
80	16	128	133	74	66.5	365	252	103	200	8.5	6.5
100	16	155	160	96	80.2	392	280	133	250	11	9

Tolerance L: +0 / -3 mm (+0 / -0.118 inch)

Dimensions [inch]										Approx. weight [kg]		
DN	Inch	PN	C	D	Di	F	G 2)	G1 2)	L 1) 3)	L 1) 4)	integral mount design	remote mount design
50	2	CL 150 / 300	3.74	3.94	1.85	1.97	13.07	8.39	4.61	4.61	14.33	9.92
65	2 1/2	CL 150	4.37	4.57	2.44	2.28	13.70	9.25	4.06	7.87	15.43	11.02
80	3	CL 150	5.04	5.24	2.91	2.62	14.37	9.92	4.06	7.87	18.74	14.33
100	4	CL 150	6.10	6.30	3.78	3.16	15.43	11.02	5.24	9.84	24.25	19.84

Tolerance L: +0 / -3 mm (+0 / -0.118 inch)

- 1) If a grounding plate is installed (attached to one side of the flange), this increases dimension L by 3 mm (0.118 inch). The mounting bracket is an option and is not available in the 3A version.
- 2) Depending on the device design, the dimensions change according to the following table.

Device design		Dimension G	Dimension G
No ignition protection	Standard temperature design	0	0
Explosion protection Zone 1, Div. 1	Standard temperature design	+74 mm (+2.91 inch)	Not available
Explosion protection Zone 2, Div. 2	Standard temperature design	0	0

- 3) Old Lay Length. Please refer to the model coding to specify the lay length (old lay length / new lay length). Old Lay Length for replacement purposes only.
- 4) New Lay Length.

9.5 Variable process connections, DN 3 ... 40 (1/10 ... 1 1/2")

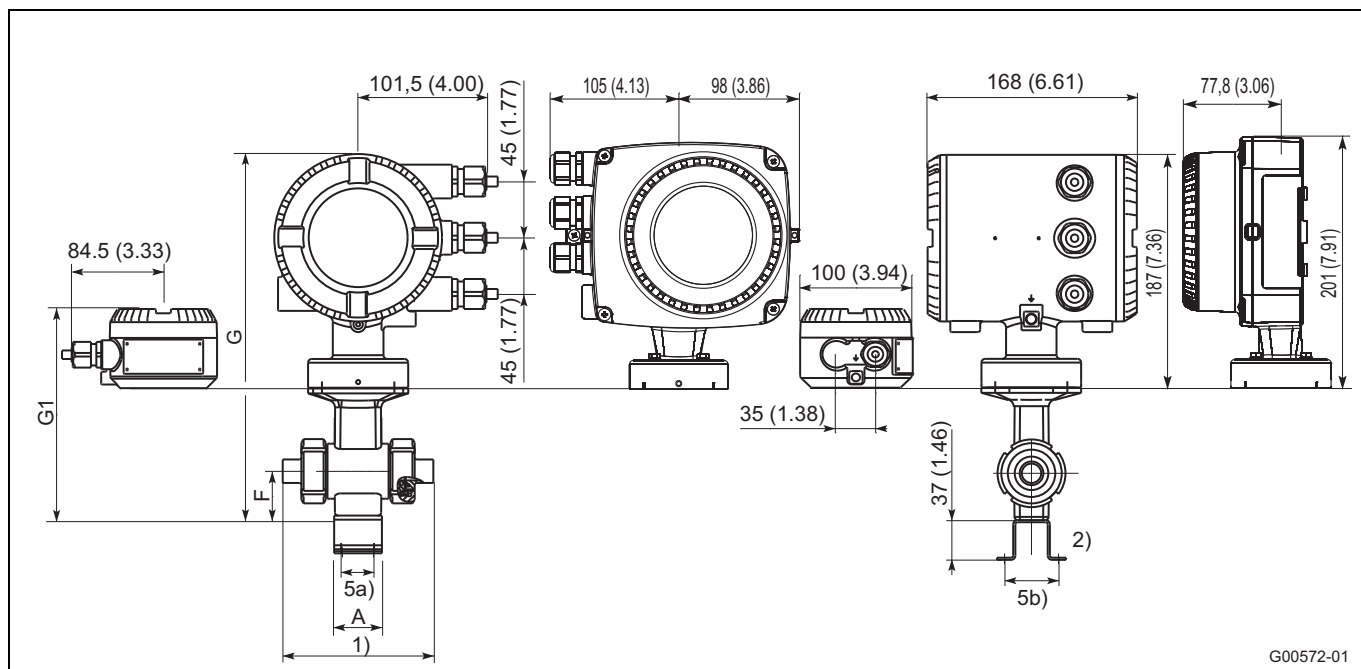

Fig. 38: Dimensions in mm (inch)

		Dimensions [mm]				Approx. weight [kg] ³⁾	
DN	PN ²⁾	A	F	G ⁴⁾	G1 ⁴⁾	Compact design	Ext. Transmitter
3 ... 8 ⁵⁾	10 ... 40	37	38.5	293	180	4	2
10	10 ... 40	37	38.5	293	180	4	2
15	10 ... 40	37	38.5	293	180	4	2
20	10 ... 40	42	43	302	190	4.5	2.5
25	10 ... 40	54	48	311	199	5	3
32	10 ... 40	62	53	321	208	5	3
40	10 ... 40	67	57	330	217	5.5	3.5

Tolerance L: +0 / -3 mm

		Dimensions [inch]				Approx. weight [lb] ³⁾	
DN	Inch	A	F	G ⁴⁾	G1 ⁴⁾	Compact design	Ext. Transmitter
3 ... 8	1/8 ... 5/16	1.5	1.52	11.5	7.1	8.82	4.41
10	3/8	1.5	1.52	11.5	7.1	8.82	4.41
15	1/2	1.5	1.52	11.5	7.1	8.82	4.41
20	3/4	1.65	1.69	11.9	7.5	9.92	5.51
25	1	2.13	1.89	12.2	7.8	11.02	6.61
32	1 1/4	2.44	2.09	12.6	8.2	11.02	6.61
40	1 1/2	2.64	2.24	13.0	8.5	12.13	7.72

Tolerance L: +0 / -0.118 inch

- 1) Installation length including process connection: Refer to page 48.
- 2) Bracket (optional), not available for 3A approval.
- 3) Plus process connection weight: Refer to page 48.
- 4) Depending on the device design, the dimensions change according to the following table.

Device design		Dimension G	Dimension G1
No ignition protection	Standard temperature design	0	0
Explosion protection Zone 1, Div. 1	Standard temperature design	+74 mm (+2.91 inch)	Not available
Explosion protection Zone 2, Div. 2	Standard temperature design	0	0

- 5) Installation hole spacing for angle bracket as per the table below.

Nominal diameter	Installation hole spacing	
	5a)	5b)
DN 3 ... 20	28 mm (1.1 inch)	50 mm (1.97 inch)
DN 25 ... 40	46 mm (1.81 inch)	70 mm (2.76 inch)

9.6 Variable process connections, DN 50 ... 100 (2 ... 4")

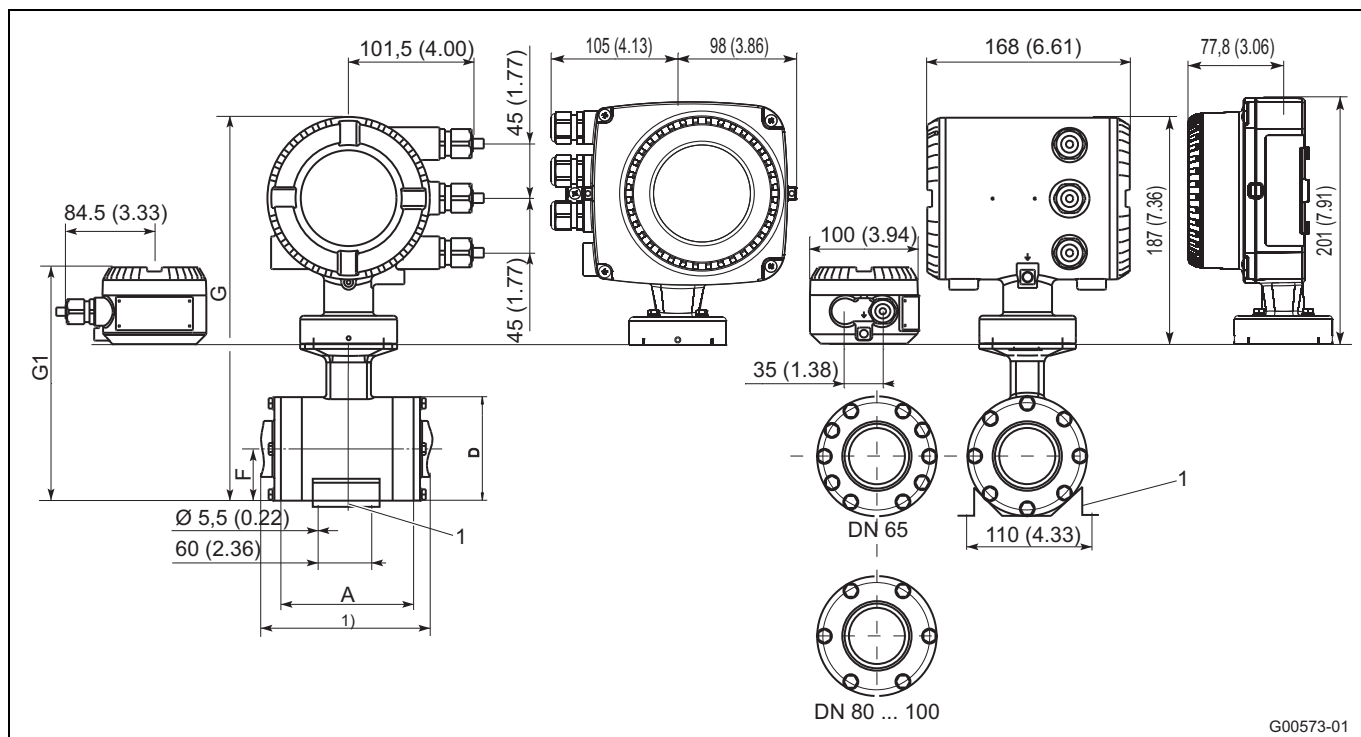

Fig. 39: Dimensions in mm (inch)

1 Bracket (optional), not available for 3A approval.

Dimensions [mm]							Approx. weight [kg] ⁴⁾	
DN	PN	A ^{1) 2)}	A ^{1) 3)}	F	G ⁵⁾	G1 ⁵⁾	integral mount design	remote mount design
50	10 ... 40	128	128	50	332	213	4	2
65	10 ... 40	114	200	58	348	235	4	2
80	10 ... 40	114	200	67	365	252	4	2
100	10 ... 40	114	250	81	393	280	4.5	2.5

Tolerance L: +0 / -3 mm (+0 / -0.118 inch)

Dimensions [mm]							Approx. weight [kg] ⁴⁾	
DN	Inch	A ^{1) 2)}	A ^{1) 3)}	F	G ⁵⁾	G1 ⁵⁾	integral mount design	remote mount design
50	2	5.04	5.04	1.97	13.06	8.39	8.82	4.41
65	2 1/2	4.49	7.87	2.28	13.70	9.26	8.82	4.41
80	3	4.49	7.87	2.64	14.37	9.92	8.82	4.41
100	4	4.49	9.84	3.19	15.45	11.01	9.92	5.51

Tolerance L: +0 / -3 mm (+0 / -0.118 inch)

- 1) Installation length including process connection: Refer to page 48.
- 2) Old lay length. Please refer to the model coding to specify the lay length (old lay length / new lay length). Old Lay Length for replacement purposes only
- 3) New Lay Length.
- 4) Plus process connection weight: Refer to page 48.
- 5) Depending on the device design, the dimensions change according to the following table.

Device design		Dimension G	Dimension G1
No ignition protection	Standard temperature design	0	0
Explosion protection Zone 1, Div. 1	Standard temperature design	+74 mm (+2.91 inch)	Not available
Explosion protection Zone 2, Div. 2	Standard temperature design	0	0

9.7 Adapter for variable process connections DN 3 ... 100 (1/10 ... 4")

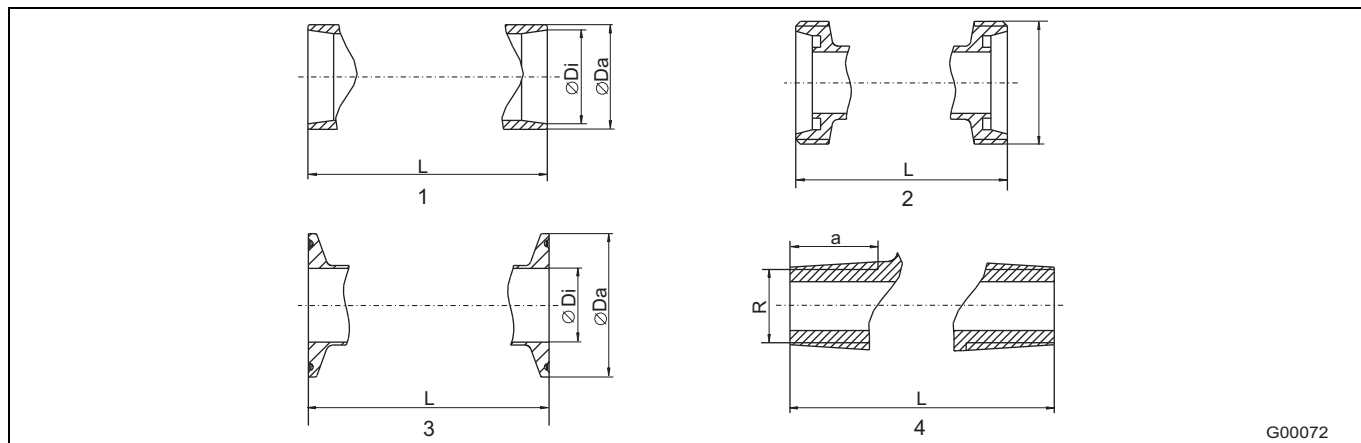

Fig. 40

- 1 Weld stubs
- 2 Threaded pipe connection in acc. with DIN 11851
- 3 Tri-Clamp
- 4 External threads

Weld stubs

Dimensions in mm

DN	ISO 2037		DIN 11850			SMS		DIN 2463		ISO 1127			L 1)	L 2)	Weight [kg]
	Ø Di	Ø Da	Ø Di	Ø Da	Series	Ø Di	Ø Da	Ø Di	Ø Da	Ø Di	Ø Da	Series			
3 ... 10	10	12	10	13	2	-	-	10,3	13,5	10,3	13,5	1	127	127	0,4
15	15,2	17,2	16	19	2	-	-	18,1	21,3	18,1	21,3	1	127	127	0,4
20	19,3	21,3	20	23	2	-	-	23,7	26,9	23,7	26,9	1	132	132	0,7
25	22,6	25	26	29	2	22,6	25	25	28	23,7	26,9	1	149	149	0,7
32	31,3	33,7	32	34	1	-	-	32	35	30,5	33,7	1	166	166	1
40	35,6	38	38	41	2	35,6	38	36,8	40	39	42,2	1	171	171	1
50	48,6	51	50	53	3	48,6	51	49	52	47,8	51	2	173	173	1
65	60,3	63,5	66	70	2	60,3	63,5	66	70	66	70	2	165	251	1,4
80	72,9	76,1	81	85	2	72,9	76,1	81	85	72,9	76,1	1	169	255	2
100	97,6	101,6	100	104	2	100	104	100	104	97,6	101,6	2	199	305	3

Dimensions in inches

DN	ISO 2037		DIN 11850			SMS		DIN 2463		ISO 1127			L 1)	L 2)	Weight [lb]
	Ø Di	Ø Da	Ø Di	Ø Da	Series	Ø Di	Ø Da	Ø Di	Ø Da	Ø Di	Ø Da	Series			
1/10 ... 3/8	0.39	0.47	0.39	0.51	2	-	-	0.41	0.53	0.41	0.53	1	5	5	0.88
1/2	0.60	0.68	0.63	0.75	2	-	-	0.71	0.84	0.71	0.84	1	5	5	0.88
3/4	0.76	0.84	0.79	0.91	2	-	-	0.93	1.06	0.93	1.06	1	5.20	5.20	1.54
1	0.89	0.98	1.02	1.14	2	0.89	0.98	0.98	1.10	0.93	1.06	1	5.87	5.87	1.54
1 1/4	1.23	1.33	1.26	1.34	1	-	-	1.26	1.38	1.20	1.33	1	6.54	6.54	2.20
1 1/2	1.40	1.50	1.50	1.61	2	1.40	1.50	1.45	1.57	1.54	1.66	1	6.73	6.73	2.20
2	1.91	2.01	1.97	2.09	3	1.91	2.01	1.93	2.05	1.88	2.01	2	6.81	6.81	2.20
2 1/2	2.37	2.50	2.60	2.76	2	2.37	2.50	2.60	2.76	2.60	2.76	2	6.50	9.88	3.09
3	2.87	3	3.19	3.35	2	2.87	3	3.19	3.35	2.87	3	1	6.65	10.04	4.41
4	3.84	4	3.94	4.09	2	3.94	4.09	3.94	4.09	3.84	4	2	7.83	12.01	6.61

1) Old Lay Length. Please refer to the model coding to specify the lay length (old lay length / new lay length). Old Lay Length for replacement purposes only .
 2) New Lay Length.

Other variable process connections

Dimensions in mm

DN	Threaded pipe connection			Tri-Clamp									
	DIN 11851			DIN 32676					ASME BPE				
	Rd. thd.	L	Weight [kg]	Ø Di	Ø Da	Series	L	Weight [kg]	Tri-Clamp	Ø Di	Ø Da	L	Weight [kg]
3 ... 10	28 x 1/8"	169 ¹⁾	0,5	10	34	3	163 ¹⁾	0,5	1/2"	9,4	25	143 ¹⁾	0,5
		169 ²⁾					163 ²⁾					143 ²⁾	
15	34 x 1/8"	169 ¹⁾	0,5	16	34	3	163 ¹⁾	0,5	3/4"	15,7	25	143 ¹⁾	0,5
		169 ²⁾					163 ²⁾					143 ²⁾	
20	44 x 1/6"	180 ¹⁾	0,9	20	34	3	168 ¹⁾	0,7	1"	22,1	50,4	143 ¹⁾	0,7
		180 ²⁾					168 ²⁾					143 ²⁾	
25	52 x 1/6"	207 ¹⁾	0,9	26	50,5	3	192 ¹⁾	0,8	1"	22,1	50,4	143 ¹⁾	1,2
		207 ²⁾					192 ²⁾					143 ²⁾	
32	58 x 1/6"	230 ¹⁾	1,4	32	50,5	3	209 ¹⁾	1,5	-	-	-	-	-
		230 ²⁾					209 ²⁾						
40	65 x 1/6"	237 ¹⁾	1,4	38	50,5	3	214 ¹⁾	1,4	1 1/2"	34,8	50,4	277 ¹⁾	1,8
		237 ²⁾					214 ²⁾					277 ²⁾	
50	78 x 1/6"	243 ¹⁾	1,4	50	64,0	3	216 ¹⁾	1,2	2"	47,5	63,9	277 ¹⁾	1,8
		243 ²⁾					216 ²⁾					277 ²⁾	
65	96 x 1/6"	245 ¹⁾	2,2	66	91,0	1	221 ¹⁾	1,6	2 1/2"	60,2	77,4	277 ¹⁾	2,0
		331 ²⁾					307 ²⁾					277 ²⁾	
80	110 x 1/4"	259 ¹⁾	3,2	81	106	1	225 ¹⁾	2,4	3"	72,9	90,9	337 ¹⁾	3,6
		345 ²⁾					311 ²⁾					337 ²⁾	
100	130 x 1/4"	307 ¹⁾	4,4	100	119	1	255 ¹⁾	3,1	4"	97,4	118,9	337 ¹⁾	4,1
		413 ²⁾					361 ²⁾					337 ²⁾	

Dimensions in inches

DN	Threaded pipe connection			Tri-Clamp									
	DIN 11851			DIN 32676					ASME BPE				
	Rd. thd.	L	Weight [lb]	Ø Di	Ø Da	Series	L	Weight [lb]	Tri-Clamp	Ø Di	Ø Da	L	Weight [lb]
1/10 ... 3/8	1.10 x 1/8"	6,65 ¹⁾	1,10	0,39	1,34	3	6,42 ¹⁾	1,10	1/2"	0,37	0,98	5,63 ¹⁾	1,10
		6,65 ²⁾					6,42 ²⁾					5,63 ²⁾	
1/2	1.34 x 1/8"	6,65 ¹⁾	1,10	0,63	1,34	3	6,42 ¹⁾	1,10	3/4"	0,62	0,98	5,63 ¹⁾	1,10
		6,65 ²⁾					6,42 ²⁾					5,63 ²⁾	
3/4	1.73 x 1/6"	7,09 ¹⁾	1,98	0,79	1,34	3	6,61 ¹⁾	1,54	1"	0,87	1,98	5,63 ¹⁾	1,54
		7,09 ²⁾					6,61 ²⁾					5,63 ²⁾	
1	2.05 x 1/6"	8,15 ¹⁾	1,98	1,02	1,99	3	7,56 ¹⁾	1,76	1"	0,87	1,98	5,63 ¹⁾	2,65
		8,15 ²⁾					7,56 ²⁾					5,63 ²⁾	
1 1/4	2.28 x 1/6"	9,06 ¹⁾	3,09	1,26	1,99	3	8,23 ¹⁾	3,31	-	-	-	-	-
		9,06 ²⁾					8,23 ²⁾						
1 1/2	2.56 x 1/6"	9,33 ¹⁾	3,09	1,50	1,99	3	8,43 ¹⁾	3,09	1 1/2"	1,37	1,98	10,91 ¹⁾	3,97
		9,33 ²⁾					8,43 ²⁾					10,91 ²⁾	
2	3.07 x 1/6"	9,57 ¹⁾	3,09	1,97	2,52	3	8,50 ¹⁾	2,65	2"	1,87	2,52	10,91 ¹⁾	3,97
		9,57 ²⁾					8,50 ²⁾					10,91 ²⁾	
2 1/2	3.78 x 1/6"	9,65 ¹⁾	4,85	2,60	3,58	1	8,70 ¹⁾	3,53	2 1/2"	2,37	3,05	10,91 ¹⁾	4,41
		13,03 ²⁾					12,09 ²⁾					10,91 ²⁾	
3	4.33 x 1/4"	10,20 ¹⁾	7,05	3,19	4,17	1	8,86 ¹⁾	5,29	3"	2,87	3,58	13,27 ¹⁾	7,94
		13,58 ²⁾					12,24 ²⁾					13,27 ²⁾	
4	5.12 x 1/4"	12,09 ¹⁾	9,70	3,94	4,69	1	10,04 ¹⁾	6,83	4"	3,83	4,68	13,27 ¹⁾	8,84
		16,26 ²⁾					14,21 ²⁾					13,27 ²⁾	

1) Old Lay Length. Please refer to the model coding to specify the lay length (old lay length / new lay length). Old Lay Length for replacement purposes only .

2) New Lay Length.

External threads ISO 228 / DIN 2999, tapered**Dimensions in mm**

DN	R	a	L	Weight [kg]
3 ... 10	3/8"	18	139	0.4
15	1/2"	18	139	0.4
20	3/4"	25	164	0.8
25	1"	25	179	0.8

Dimensions in inches

DN	R	a	L	Weight [lb]
1/10 ... 3/8	3/8"	0.71	5.47	0.88
1/2	1/2"	0.71	5.47	0.88
3/4	3/4"	0.98	6.46	1.76
1	1"	0.98	7.05	1.76

Weld stubs suitable for OD tubing**Dimensions in mm**

DN	Weld stub size	Di	Da	L	Weight [kg]
10 (3/8")	1/2"	9.40	12.70	127	0.4
15 (1/2")	3/4"	15.75	19.05	127	0.4
20 (1")	1"	22.10	25.40	132	0.7
25 (1")	1"	22.10	25.40	149	1
40 (1 1/2")	1 1/2"	34.80	38.10	171	1
50 (2")	2"	47.50	50.80	173	1

Dimensions in inches

DN	Weld stub size	Di	Da	L	Weight [lb]
10 (3/8")	1/2"	0.37	0.50	5	0.9
15 (1/2")	3/4"	0.62	0.75	5	0.9
20 (1")	1"	0.87	1	5.20	1.5
25 (1")	1"	0.87	1	5.87	2.2
40 (1 1/2")	1 1/2"	1.37	1.50	6.73	2.2
50 (2")	2"	1.87	2	6.81	2.2

9.8 1/8" sanitary connections DN 1 ... 2 (1/25 ... 3/32")

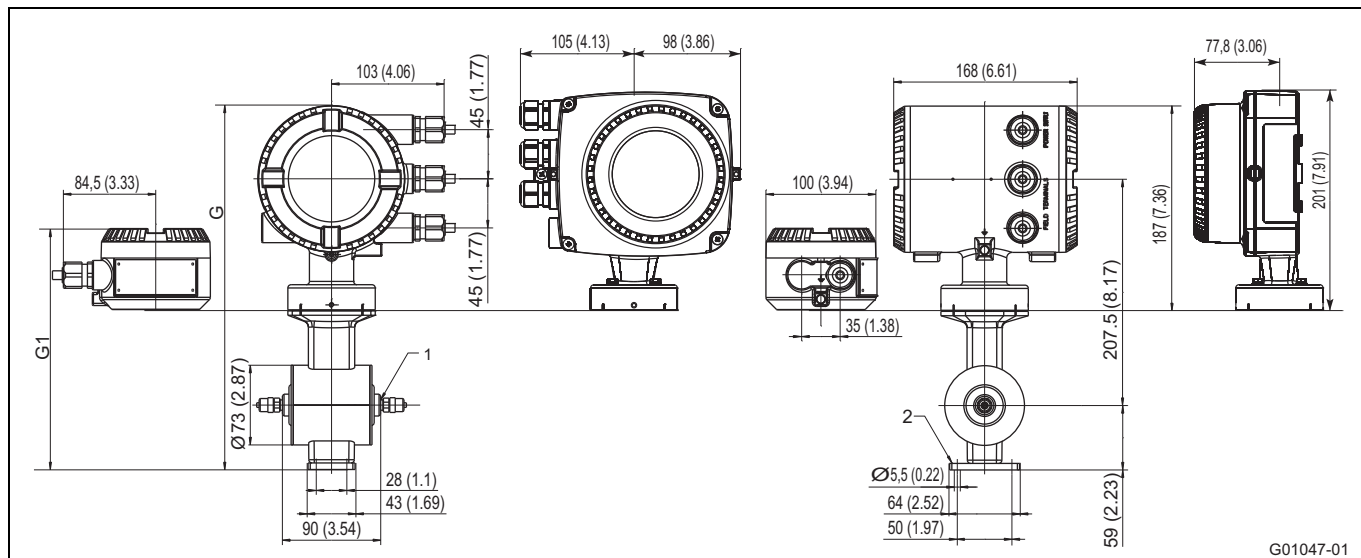

Fig. 41: Dimensions in mm (inch)

1 Connecting dimensions for gland: G 1/8" female thread

2 Mounting bracket (standard)

Dimensions [mm]				Approx. weight [kg]	
Process connection	PN	G	G1	Integral mount design	Remote mount design
1/8" sanitary connectors ¹⁾	10	334	221	5	3

Dimensions [inch]				Approx. weight [lb]	
Process connection	PN	G	G1	Integral mount design	Remote mount design
1/8" sanitary connectors ¹⁾	10	13.15	8.70	11	6.6

1) For hose 6 x 4 mm (0.24 x 0.16 inch).

9.9 Transmitter housing (dual-compartment housing) model FET521 and FET525 Zone 2, Div 2

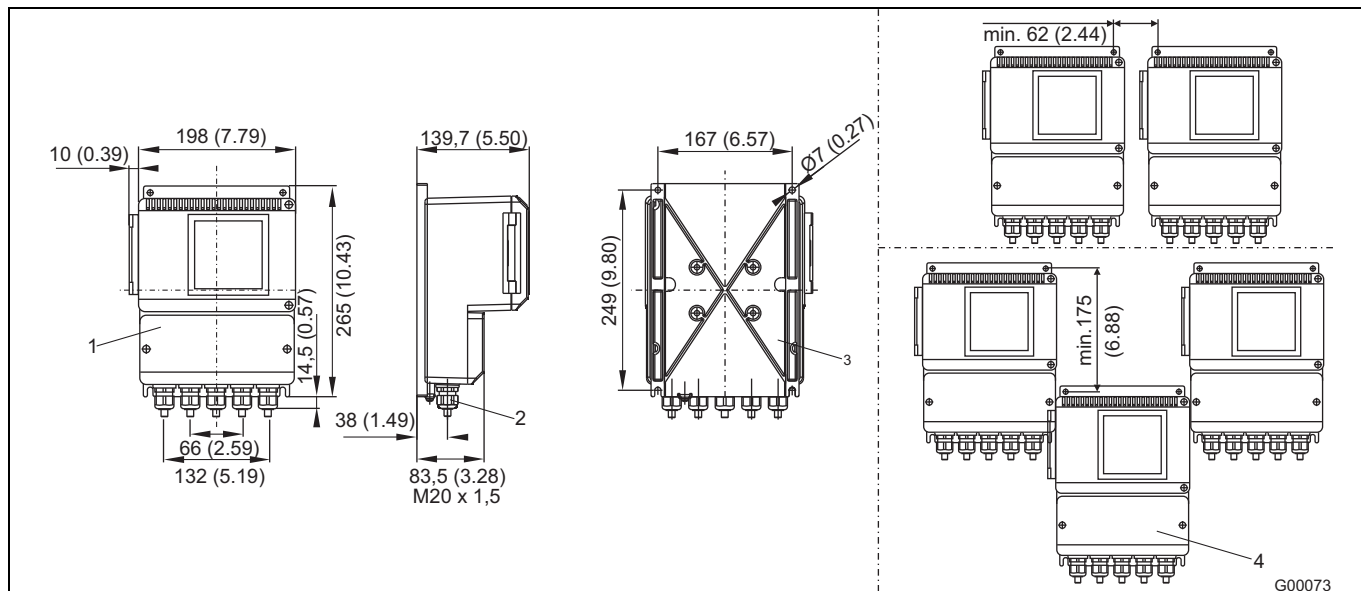

Fig. 42: Dimensions in mm (inch)

- 1 Field-mount housing with window
- 2 Cable gland M20 x 1.5
- 3 Installation holes for pipe mounting set, for 2" pipe installation; mounting set available on request (order no. 3KXF081100L0001)
- 4 Protection class IP 67

9.10 Transmitter housing (single-compartment housing) model FET521

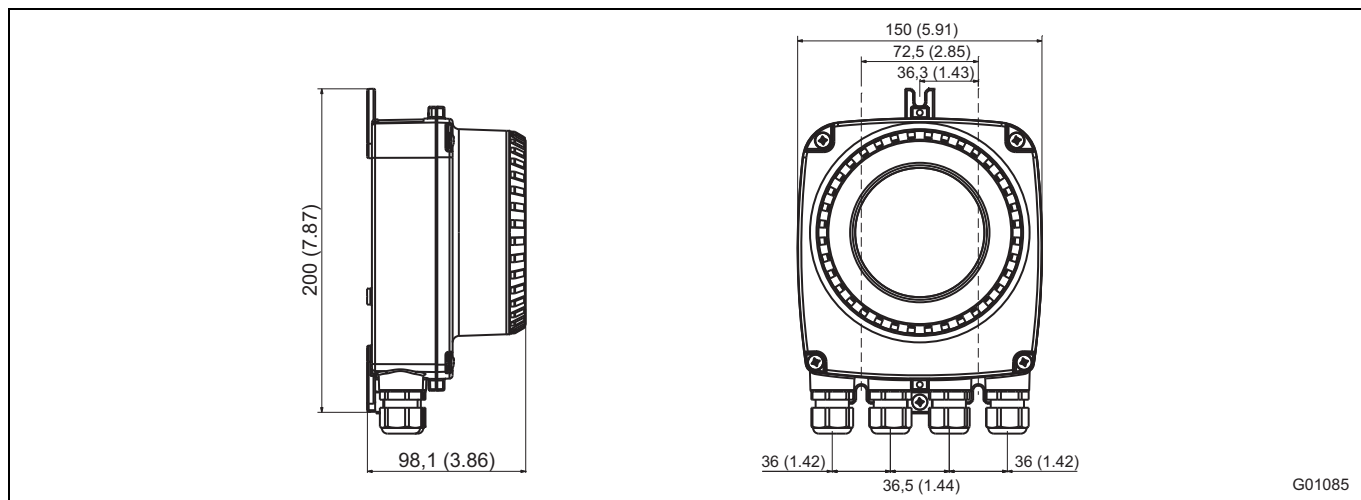

Fig. 43: Dimensions in mm (inch)

10 Ordering information

10.1 HygienicMaster FEH511, FEH515 electromagnetic flowmeter, compact design

Version number	Main order number																											Add. order no.
	1 - 6	7	8	9	10	11	12	13	14	15	16	17	18	19	20	21	22	23	24	25	26	27						
Without explosion protection	FEH511	X	X	X	X	X	X	X	X	X	X	X	X	X	X	X	X	X	X	X	X	X	X	X	X	XX		
With explosion protection	FEH515	X	X	X	X	X	X	X	X	X	X	X	X	X	X	X	X	X	X	X	X	X	X	X	X	XX		
Nominal diameter																												
DN 1 (1/25 in.)	1)	1	1	1																								
DN 1.5 (1/17 in.)	1)	1	1	5																								
DN 2 (1/12 in.)	1)	1	1	2																								
DN 3 (1/10 in.)		0	0	3																								
DN 4 (5/32 in.)		0	0	4																								
DN 6 (1/4 in.)		0	0	6																								
DN 8 (5/16 in.)		0	0	8																								
DN 10 (3/8 in.)		0	1	0																								
DN 15 (1/2 in.)		0	1	5																								
DN 20 (3/4 in.)		0	2	0																								
DN 25 (1 in.)		0	2	5																								
DN 32 (1-1/4 in.)		0	3	2																								
DN 40 (1-1/2 in.)		0	4	0																								
DN 50 (2 in.)		0	5	0																								
DN 65 (2-1/2 in.)		0	6	5																								
DN 80 (3 in.)		0	8	0																								
DN 100 (4 in.)		1	0	0																								
Lining material																												
PFA																												
PEEK			1)																									
Electrode design																												
Standard																												
Pointed head																												
Signal electrode material																												
Stainless steel 1.4539 (904)																												
Hastelloy C-4 (2.4610)																												
Titanium																												
Tantalum																												
Hastelloy B-3 (2.4600)																												
Platinum-iridium																												
Stainless steel 1.4571 (316Ti)																												
Grounding accessories																												
Standard																												
Grounding electrodes (for material, refer to "Signal electrode material")																												
Process connection																												
Flange DIN PN 16																												
Flange DIN PN 40																												
Flange, ASME CL 150																												
Flange, ASME CL 300																												
Flange, JIS 10K																												
External threads ISO 228 / DIN 2999 (tapered)																												
Cable gland in acc. with DIN 11851																												
Weld stubs in acc. with ISO 2037																												
Weld stubs in acc. with DIN 2463																												
Weld stubs in acc. with DIN 11850																												
Weld stubs in acc. with ISO 1127																												
Weld stubs suitable for OD tubing																												
Weld stubs in acc. with SMS																												

Continued on next page

- 1) Model FEH511 DN1 - 2 only
- 2) Only with DN 100 (4 in.).
- 3) Only DN 3 ... 80 (1/10 ... 3 in.).
- 4) Refer to the data sheet for available nominal diameters and the nominal pressure rating

Continued

Version number	Main order number																											Add. order no.
	1-6	7	8	9	10	11	12	13	14	15	16	17	18	19	20	21	22	23	24	25	26	27						
Without explosion protection	FEH511	X	X	X	X	X	X	X	X	X	X	X	X	X	X	X	X	X	X	X	X	X	X	X	X	XX		
With explosion protection	FEH515	X	X	X	X	X	X	X	X	X	X	X	X	X	X	X	X	X	X	X	X	X	X	X	X	XX		
Process connection																												
Tri-Clamp in acc. with DIN 32676											4) T																	
Tri-Clamp in acc. with ASME BPE											4) T																	
Wafer type											4) W																	
1/8 in. sanitary connectors											1) M																	
Without adapter											5) Y																	
Process connection material																												
Stainless steel											6) D																	
Stainless steel with EPDM gasket											E																	
Stainless steel with EPDM gasket and mounting fixture											7) F																	
Stainless steel with silicone gasket											G																	
Stainless steel with silicone gasket and mounting fixture											7) H																	
Without process connection or gasket; with attachment											8) W																	
Without process connection, gasket, or attachment											8) Y																	
PVC (with 1/8" sanitary connectors)											1) P																	
POM (with 1/8" sanitary connectors)											1) M																	
Certificates																												
Meter tube with PED approval											0																	
Acceptance test certificate (3.1) to EN 10204											2																	
Pressure test to AD-2000											3																	
Material certificate 3.1 to EN 10204 and pressure test to AD-2000											4																	
Calibration																												
Standard accuracy											9) A																	
Increased accuracy											10) B																	
Standard accuracy + ScanMaster function											9) K																	
Increased accuracy + ScanMaster function											10) L																	
Standard accuracy for certified calibration											M																	
5-point DKD calibration											T																	
Sensor temperature range / Ambient temperature range																												
Standard sensor design / -20 ... 60 °C (-4 ... 140 °F)											11)		1															
Standard sensor design / -40 ... 60 °C (-4 ... 140 °F)											11)		2															
High-temperature sensor design / -20 ... 60 °C (-4 ... 140 °F)											12)		3															
High-temperature sensor design / -40 ... 60 °C (-4 ... 140 °F)											12)		4															
Name plate																												
Sticker													A															
Stainless steel													B															
Stainless steel, and TAG label stainless steel													C															
Signal cable length																												
No cable													0															

Continued on next page

- 1) Model FEH511 DN1 ... 2 only
- 4) Refer to the data sheet for available nominal diameters and the nominal pressure rating
- 5) Spare sensor, for replacement purposes only.
- 6) Must be specified for flange connection or 1/8" sanitary connectors.
- 7) 3A conformity not available.
- 8) 3A conformity not available. Must be specified for "wafer type" or "without adapter" process connection types.
- 9) Standard accuracy (DN3 ... 100, 0.3 % of rate) assumes 2 calibration points. If more than 2 calibration points are required, you must specify 3 or 5 points under "Number of test points". Accuracy for DN1 ... 2, 0.7 % of rate.
- 10) Increased accuracy (DN10 ... 100, 0.2 % of rate) assumes 3 calibration points. If more than 3 calibration points are required, you must specify 5 points under "Number of test points". Not available for DN1 ... 8 (1/25 ... 5/16 in.).
- 11) Maximum fluid temperature for standard sensor design: 130 °C (266°F) with PFA, DN 1 ... 2: 120 °C (248 °F).
- 12) Maximum fluid temperature for high-temperature sensor design: 180 °C (356°F) with PFA. High-temperature sensor design is only available with units with a "flange" process connection.

Continued

Version number	Main order number																											Add. order no.	
	1-6	7	8	9	10	11	12	13	14	15	16	17	18	19	20	21	22	23	24	25	26	27							
Without explosion protection	FEH511	X	X	X	X	X	X	X	X	X	X	X	X	X	X	X	X	X	X	X	X	X	X	X	X	X	X	XX	
With explosion protection	FEH515	X	X	X	X	X	X	X	X	X	X	X	X	X	X	X	X	X	X	X	X	X	X	X	X	X	X	XX	
Explosion protection																													
None																													
ATEX / IEC Zone 1																													
ATEX / IEC Zone 2 / 21																													
usFMc Div 2 Zone 2																													
usFMc Div 1																													
Protection type for transmitter / sensor																													
Standard / IP 67 (NEMA 4X)																													
Cable gland																													
M20 x 1.5																													
1/2 in. NPT																													
PF 1/2 in.																													
Power supply																													
100 ... 230 V AC, 50 Hz																													
24 V AC / DC, 50 Hz																													
100 ... 230 V AC, 60 Hz																													
24 V AC / DC, 60 Hz																													
Signal inputs / outputs																													
HART + 20 mA passive + pulses + contact input / output																													
HART + 20 mA active + pulses + contact input / output																													
HART + 20 mA active + pulses + contact output																													
PROFIBUS PA + contact output																													
FOUNDATION Fieldbus + contact output																													
Default settings / Diagnostics																													
Parameters are at factory settings / Extended diagnostics functions activated																													
Parameters are set according to customer specifications / Extended diagnostics functions activated																													
Accessories																													
None																													
Plug connector																													
M12 x 1 fieldbus																													
Housing design																													
Single-compartment housing																													
Dual-compartment housing																													
Lay Length																													
Old length for DN 65, DN 80, DN 100																													
New length for DN 65, DN 80, DN 100																													
Additional options																													
With Gore-Tex diaphragm																													
Number of test points																													
3 points																													
5 points																													
Language of documentation																													
German																													
English																													
Chinese																													
Russian																													
Western Europe / Scandinavia language package (languages: DE, EN, DA, ES, FR, IT, NL, PT, FI, SV)																													
Eastern Europe language package (languages: DE, EL, CS, ET, LV, LT, HU, PL, SK, SL, RO, BG)																													

13) Only available for model FEH515. Zone 21 dust explosion protection only possible in conjunction with dual-compartment transmitter housing.

14) Transmitter degree of protection = IP67 (NEMA 4X) with single-compartment and dual-compartment transmitter housing

15) Choice with design Zone 2 / Div 2 or Zone 1 / Div1.

16) Choice with design Zone 2 / Div 2.

17) Choice with design Zone 1 / Div 1.

18) Only for PROFIBUS PA Not for model FEH515.

19) 3A approval not available.

20) Old Lay Length for replacement purposes only.

21) Only available for model FEH511.

10.2 HygienicMaster FEH521, FEH525 electromagnetic flowmeter, remote mount design

Version number	Main order number																											Add. order no.	
	1 - 6	7	8	9	10	11	12	13	14	15	16	17	18	19	20	21	22	23	24	25	26	27							
Without explosion protection	FEH521	X	X	X	X	X	X	X	X	X	X	X	X	X	X	X	X	X	X	X	X	X	X	X	X	X	XX		
With explosion protection	FEH525	X	X	X	X	X	X	X	X	X	X	X	X	X	X	X	X	X	X	X	X	X	X	X	X	X	XX		
Nominal diameter																													
DN 1 (1/25 in.)	1)	1	1	1																									
DN 1.5 (1/17 in.)	1)	1	1	5																									
DN 2 (1/12 in.)	1)	1	1	2																									
DN 3 (1/10 in.)		0	0	3																									
DN 4 (5/32 in.)		0	0	4																									
DN 6 (1/4 in.)		0	0	6																									
DN 8 (5/16 in.)		0	0	8																									
DN 10 (3/8 in.)		0	1	0																									
DN 15 (1/2 in.)		0	1	5																									
DN 20 (3/4 in.)		0	2	0																									
DN 25 (1 in.)		0	2	5																									
DN 32 (1-1/4 in.)		0	3	2																									
DN 40 (1-1/2 in.)		0	4	0																									
DN 50 (2 in.)		0	5	0																									
DN 65 (2-1/2 in.)		0	6	5																									
DN 80 (3 in.)		0	8	0																									
DN 100 (4 in.)		1	0	0																									
Lining material																													
PFA																													
PEEK																													
Electrode design																													
Standard																													
Pointed head																													
Signal electrode material																													
Stainless steel 1.4539 (904)																													
Hastelloy C-4 (2.4610)																													
Titanium																													
Tantalum																													
Hastelloy B-3 (2.4600)																													
Platinum-iridium																													
Stainless steel 1.4571 (316Ti)																													
Grounding accessories																													
Standard																													
Grounding electrodes (for material, refer to "Signal electrode material")																													
Process connection																													
Flange DIN PN 16																													
Flange DIN PN 40																													
Flange, ASME CL 150																													
Flange, ASME CL 300																													
Flange, JIS 10K																													
External threads ISO 228 / DIN 2999 (tapered)																													
Cable gland in acc. with DIN 11851																													
Weld stubs in acc. with ISO 2037																													
Weld stubs in acc. with DIN 2463																													
Weld stubs in acc. with DIN 11850																													
Weld stubs in acc. with ISO 1127																													
Weld stubs suitable for OD tubing																													
Weld stubs in acc. with SMS																													

Continued on next page

- 1) Only with model FEH521 DN 1 ... 2.
- 2) Only with DN 100 (4 in.).
- 3) Only DN 3 ... 80 (1/10 ... 3 in.).
- 4) Refer to the data sheet for available nominal diameters and the nominal pressure rating

Continued

Version number	Main order number																											Add. order no.						
	1-6	7	8	9	10	11	12	13	14	15	16	17	18	19	20	21	22	23	24	25	26	27												
Without explosion protection	FEH521	X	X	X	X	X	X	X	X	X	X	X	X	X	X	X	X	X	X	X	X	X	X	X	X	XX								
With explosion protection	FEH525	X	X	X	X	X	X	X	X	X	X	X	X	X	X	X	X	X	X	X	X	X	X	X	X	XX								
Process connection																																		
Tri-Clamp in acc. with DIN 32676											4)	T	1																					
Tri-Clamp in acc. with ASME BPE											4)	T	3																					
Wafer type											4)	W	1																					
1/8 in. sanitary connectors											1)	M	3																					
Without adapter											5)	Y	0																					
Process connection material																																		
Stainless steel											6)	D																						
Stainless steel with EPDM gasket													E																					
Stainless steel with EPDM gasket and mounting fixture											7)	F																						
Stainless steel with silicone gasket													G																					
Stainless steel with silicone gasket and mounting fixture											7)	H																						
Without process connection or gasket; with attachment											8)	W																						
Without process connection, gasket, or attachment											8)	Y																						
PVC (with 1/8" sanitary connectors)											1)	P																						
POM (with 1/8" sanitary connectors)											1)	M																						
Certificates																																		
Meter tube with PED approval													0																					
Acceptance test certificate (3.1) to EN 10204													2																					
Pressure test to AD-2000													3																					
Material certificate 3.1 to EN 10204 and pressure test to AD-2000													4																					
Calibration																																		
Standard accuracy											9)	A																						
Increased accuracy											10)	B																						
Standard accuracy + ScanMaster function											9)	K																						
Increased accuracy + ScanMaster function											10)	L																						
Standard accuracy for certified calibration													M																					
5-point DKD calibration													T																					
Sensor temperature range / Ambient temperature range																																		
Standard sensor design / -20 ... 60 °C (-4 ... 140 °F)											11)	1																						
Standard sensor design / -40 ... 60 °C (-4 ... 140 °F)											11)	2																						
High-temperature sensor design / -20 ... 60 °C (-4 ... 140 °F)											12)	3																						
High-temperature sensor design / -40 ... 60 °C (-4 ... 140 °F)											12)	4																						
Name plate																																		
Sticker													A																					
Stainless steel													B																					
Stainless steel, and TAG label stainless steel													C																					

Continued on next page

- 1) Only with model FEH521 DN1 ... 2.
- 4) Refer to the data sheet for available nominal diameters and the nominal pressure rating
- 5) Spare sensor, for replacement purposes only.
- 6) Must be specified for flange connection or 1/8" sanitary connectors.
- 7) 3A conformity not available.
- 8) 3A conformity not available. Must be specified for "wafer type" or "without adapter" process connection types.
- 9) Standard accuracy (DN3 ... 100, 0.3 % of rate) assumes 2 calibration points. If more than 2 calibration points are required, you must specify 3 or 5 points under "Number of test points". Accuracy for DN1 ... 2, 0.7 % of rate.
- 10) Increased accuracy (DN10 ... 100, 0.2 % of rate) assumes 3 calibration points. If more than 3 calibration points are required, you must specify 5 points under "Number of test points". Not available for DN1 ... 8 (1/25 ... 5/16 in.).
- 11) Maximum fluid temperature for standard sensor design: 130 °C (266°F) with PFA.
- 12) Maximum fluid temperature for high-temperature sensor design: 180 °C (356°F) with PFA. High-temperature sensor design is only available with units with a "flange" process connection.

Continued

Version number	Main order number																				Add. order no.		
	1-6	7	8	9	10	11	12	13	14	15	16	17	18	19	20	21	22	23	24	25		26	27
Without explosion protection	FEH521	X	X	X	X	X	X	X	X	X	X	X	X	X	X	X	X	X	X	X	X	X	XX
With explosion protection	FEH525	X	X	X	X	X	X	X	X	X	X	X	X	X	X	X	X	X	X	X	X	X	XX
Signal cable length																							
No cable																							0
5 m (approx. 15 ft.) standard cable																							1
10 m (approx. 30 ft.) standard cable																							2
20 m (approx. 60 ft.) standard cable																							3
30 m (approx. 100 ft.) standard cable																							4
50 m (approx. 165 ft.) standard cable																							5
80 m (approx. 260 ft.) standard cable																							6
100 m (approx. 325 ft.) standard cable																							7
150 m (approx. 490 ft.) standard cable																							8
Explosion protection																							
None																							A
ATEX / IEC Zone 2 / 21																							13) M
usFMc Div 2 Zone 2																							13) P
Protection type for transmitter / sensor																							
Standard / IP 67 (NEMA 4X)																							14) 1
Standard / IP 68 (NEMA 6P)																							14)15) 2
Standard / IP 68 (NEMA 6P), signal cable connected and sealed in																							14) 3
Cable gland																							
M20 x 1.5																							A
1/2 in. NPT																							B
PF 1/2 in.																							C
Power supply																							
None																							0
Signal inputs / outputs																							
None																							Y
Default settings / Diagnostics																							
Parameters are at factory settings / Extended diagnostics functions activated																							2
Parameters are set according to customer specifications / Extended diagnostics functions activated																							4
Accessories																							
None																							
With preamplifier, integrated into sensor housing																							16)
Lay Length																							
Old length for DN 65, DN 80, DN 100																							17)
New length for DN 65, DN 80, DN 100																							
Line frequency																							
50 Hz (When ordering the sensor without a transmitter, specify the mains frequency.)																							F5
60 Hz (When ordering the sensor without a transmitter, specify the mains frequency.)																							F6
Additional options																							
With Gore-Tex diaphragm																							18)
Language of documentation																							
German																							M1
English																							M5
Chinese																							M6
Russian																							MB
Western Europe / Scandinavia language package (languages: DE, EN, DA, ES, FR, IT, NL, PT, FI, SV)																							MW
Eastern Europe language package (languages: DE, EL, CS, ET, LV, LT, HU, PL, SK, SL, RO, BG)																							ME
Number of test points																							
3 points																							P3
5 points																							P5

- 13) Only available for model FEH515.
- 14) Transmitter degree of protection = IP67 (NEMA 4X) with single-compartment and dual-compartment housing.
- 15) Only with external transmitter, sealing compound (optional) D141B038U01.
- 16) Preamplifier required if signal cable length is > 50 m (160 ft).
- 17) Old Lay Length for replacement purposes only.
- 18) Only available for model FEH525.

10.3 FET521, FET525 external transmitter for HygienicMaster

	Main order number															Add. order no.
	Version number	1 – 6	7	8	9	10	11	12	13	14	15					
Without explosion protection	FET521	X	X	X	X	X	X	X	X	X	X	X	X	X	X	XX
With explosion protection	FET525	X	X	X	X	X	X	X	X	X	X	X	X	X	X	XX
Sensor temperature range / Ambient temperature range																
Standard sensor design / -20 ... 60 °C (-4 ... 140 °F)		1														
Standard sensor design / -40 ... 60 °C (-4 ... 140 °F)		2														
High-temperature sensor design / -20 ... 60 °C (-4 ... 140 °F)		3														
High-temperature sensor design / -40 ... 60 °C (-4 ... 140 °F)		4														
Name plate																
Sticker			A													
Stainless steel			B													
Stainless steel, and TAG label stainless steel			C													
Signal cable length																
No cable				0												
Explosion protection																
None							A									
ATEX / IEC Zone 2 / 21				1)			M									
usFMc Div 2 Zone 2				1)			P									
Protection type for transmitter / sensor																
Standard / IP 67 (NEMA 4X)					2)		1									
Cable gland																
M20 x 1.5								A								
1/2 in. NPT								B								
PF 1/2 in.								C								
None								Y								
Power supply																
100 ... 230 V AC, 50 Hz													1			
24 V AC / DC, 50 Hz													2			
100 ... 230 V AC, 60 Hz													3			
24 V AC / DC, 60 Hz													4			
Signal inputs / outputs																
HART + 20 mA passive + pulses + contact input / output										3)				B		
HART + 20 mA active + pulses + contact input / output										4)				C		
PROFIBUS PA + contact output														E		
FOUNDATION Fieldbus + contact output														F		
Default settings / Diagnostics																
Without / standard diagnostic functions												5)		0		
Parameters are at factory settings / Extended diagnostics functions activated														2		
Parameters are set according to customer specifications / Extended diagnostics functions activated														4		
Plug connector																
M12 x 1 fieldbus														6)		U2
Transmitter housing design																
Single-compartment housing														7)		H1
Dual-compartment housing																H2
Additional options																
With Gore-Tex diaphragm														7)		KG
Language of documentation																
German																M1
English																M5
Chinese																M6
Russian																MB
Western Europe / Scandinavia language package (languages: DE, EN, DA, ES, FR, IT, NL, PT, FI, SV)																MW
Eastern Europe language package (languages: DE, EL, CS, ET, LV, LT, HU, PL, SK, SL, RO, BG)																ME

- 1) Model FET525 only.
- 2) Transmitter degree of protection = IP67 (NEMA 4X) with single-compartment and dual-compartment housing.
- 3) Choice with design Zone 2 / Div 2 or Zone 1 / Div1.
- 4) Choice with design Zone 2 / Div 2.
- 5) Must be selected if transmitter is being ordered as a spare part or without a sensor.
- 6) Only for Profibus PA, not for model FET525.
- 7) Only with model FET521.

10.4 FET501 transmitter plug-in module for ProcessMaster/HygienicMaster

	Main order number										Additional order no.						
	Version number	1-6	7	8	9	10	11	12	13	14		15					
		FET501	X	X	X	X	X	X	X	X	X	X	X	X	X	X	
Temperature Range of Installation / Ambient Temperature Range Standard design / -20 ... 60 °C (-4 ... 140 °F)			1														X
Name Plate Adhesive label				A													
Signal Cable Length and Type Without signal cable					0												
Explosion Protection Certification Without						A											
Protection Class Transmitter / Protection Class Sensor Others								9									
Cable Conduits Others										Z							
Power Supply 100 ... 230 V AC, 50 Hz 24 V AC / DC, 50 Hz 100 ... 230 V AC, 60 Hz 24 V AC / DC, 60 Hz													1				
													2				
													3				
													4				
Input and Output Signal Type HART + 20 mA passive + Pulse + Contact I/O HART + 20 mA active + Pulse + Contact I/O PROFIBUS PA + contact output FOUNDAs FOUNDATION Fieldbus + contact output																	B C E F
Configuration Type / Diagnostics Type Without / Standard diagnostic functions																	0
Language of Documentation German English Chinese Russian Language package Western Europe / Scandinavia (Languages: DE, EN, DA, ES, FR, IT, NL, PT, FI, SV) Language package Eastern Europe (Languages: DE, EL, CS, ET, LV, LT, HU, PL, SK, SL, RO, BG)																	M1 M5 M6 MB MW ME

10.5 Flowmeter sensor simulator - FXC4000

	Main order number						
	Version number	1-5	6	7	8	9	10
		55XC4	X	X	X	X	X
Flow Signal Setting Without (adapter only) 3-position digitswitch with 1000 steps			0 1				
Power Supply Without (adapter only) 110 ... 240 V AC 50 / 60 Hz // With Schuko plug 24 ... 48 V AC / DC // With 4 mm plug 110 ... 240 V AC 50 / 60 Hz // With US plug				0 1 2 3			
Accessories Without Adapter for converter type FXE4000-E4, FXM2000-XM2, FXF2000-DF23 Adapter board for converter type FSM4000-S4 Adapter board for converter type FET321, FET325, FET521, FET525				0 1 5 6			
Design level (specified by ABB)							*
Name Plate German English French						1 2 3	

10.6 Ordering information Wafer type Accessories (Table H)

Wafer type Accessories

Description	Nominal size	Nominal pressure rating	Order number
FX / FSM Wafer type Accessories	DN 3 ... DN 10 (1/10 ... 3/8 in.)	PN 10 ... PN 40	D614L265U03
		ASME CL 150	D614L265U03
		ASME CL 300	D614L265U04
	DN 15 (1/2 in.)	PN 10 ... PN 40	D614L265U03
		ASME CL 150	D614L266U05
		ASME CL 300	D614L266U06
	DN 20 (3/4 in.)	PN 10 ... PN 40	D614L267U04
		ASME CL 150	D614L267U05
		ASME CL 300	D614L267U06
	DN 25 (1 in.)	PN 10 ... PN 40	D614L268U04
ASME CL 150		D614L268U05	
ASME CL 300		D614L268U06	
DN 32 (1-1/4 in.)	PN 10 ... PN 40	D614L269U04	
	ASME CL 150	D614L269U05	
	ASME CL 300	D614L269U06	
DN 40 (1-1/2 in.)	PN 10 ... PN 40	D614L270U04	
	ASME CL 150	D614L270U05	
	ASME CL 300	D614L270U06	
DN 50 (2 in.)	PN 10 ... PN 40	D614L296U04	
	ASME CL 150	D614L296U05	
	ASME CL 300	D614L296U06	
DN 65 (2-1/2 in.)	PN 10 ... PN 16	D614L297U08	
	PN 25 ... PN 40	D614L297U09	
	ASME CL 150	D614L297U10	
	ASME CL 300	D614L297U11	
DN 80 (3 in.)	PN 10 ... PN 40	D614L298U08	
	ASME CL 150	D614L298U09	
	ASME CL 300	D614L298U10	
DN 100 (4 in.)	PN 10 ... PN 16	D614L299U07	
	PN 25 ... PN 40	D614L299U08	
	ASME CL 150	D614L299U09	

Welding adapter

Material	Nominal size	Order number
Stainless steel AISI 304 (1.4301)	DN 3 ... DN 10 (1/10 ... 3/8 in.)	D413C470U01
		D413C471U01
		D413C472U01
	DN 25 (1 in.)	D413C473U01
		D413C474U01
		D413C475U01
		D413C488U03
	DN 65 (2-1/2 in.)	D413C461U09
		D413C496U03
		D413C498U03

The adapter is a tool for sensors that feature weld stubs as the process connection type. It enables these weld stubs to be welded into the pipeline in a coplanar manner.

10.7 Diagnostic and verification software - ScanMaster FZC500



ScanMaster allows you to easily check the installed device for proper functioning. The determined test and verification results are stored in a database and can be printed if required.

ScanMaster is based on DTM technology and can be run on Asset Vision Basic or other frame applications (as of FDT 1.2).

There are two ways to communicate with the device.

- Via a HART modem
- Via FZA100 infrared service port adapter

10.7.1 Communication via HART protocol on the 20 mA line

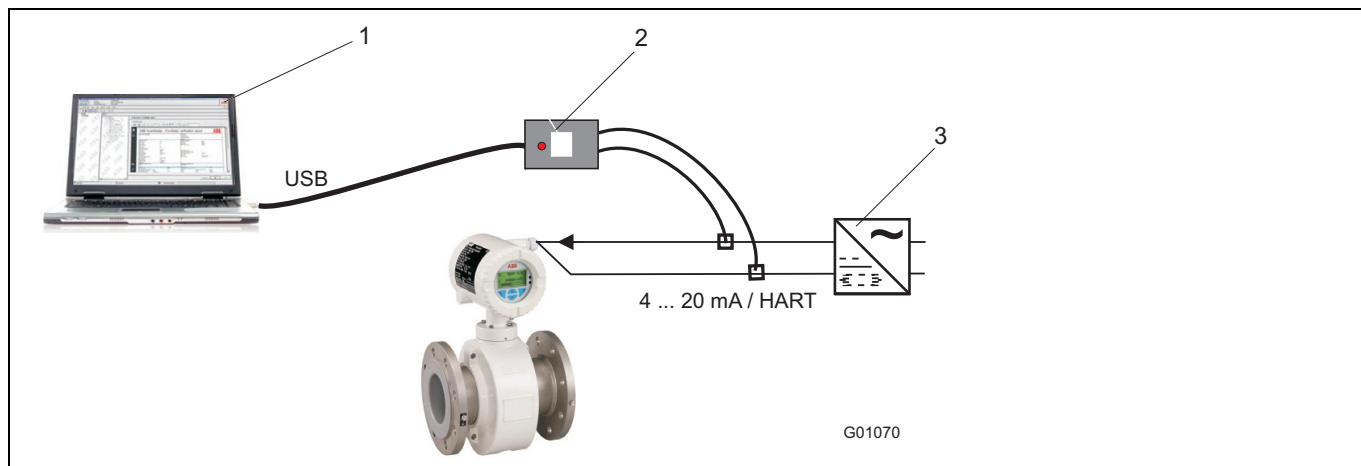

Fig. 44

- | | |
|--|---|
| <p>1 Frame application,
e.g., DAT200 Asset Vision Basic
- Communication DTM: "is HRT USB"
- ScanMaster DTM</p> | <p>2 USB HART FSK / PC modem, electrical isolation,
e.g., NHA121Nx (Ex)
or NHA121No (Std.)</p> <p>3 Power supply unit</p> |
|--|---|

10.7.2 Communication via FZA100 infrared adapter

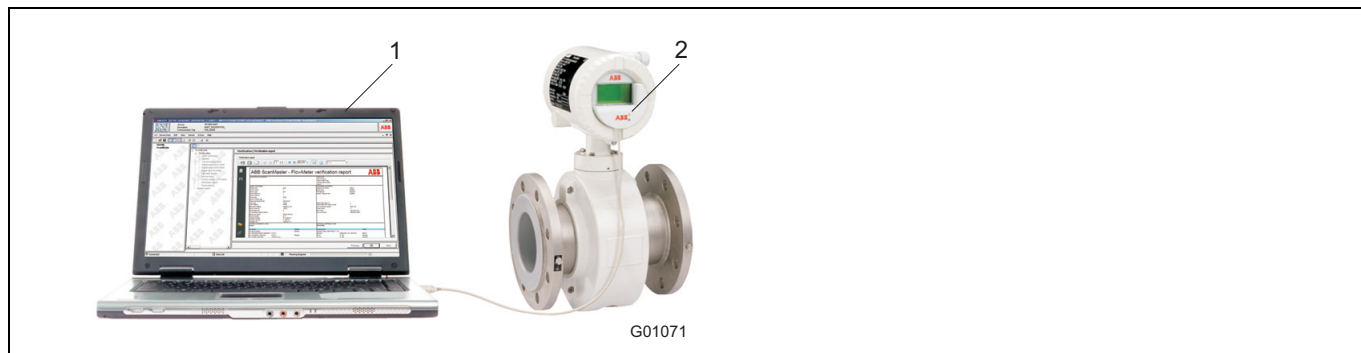
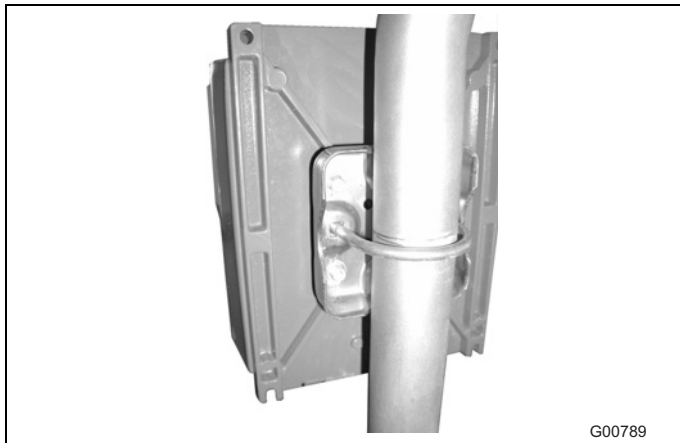
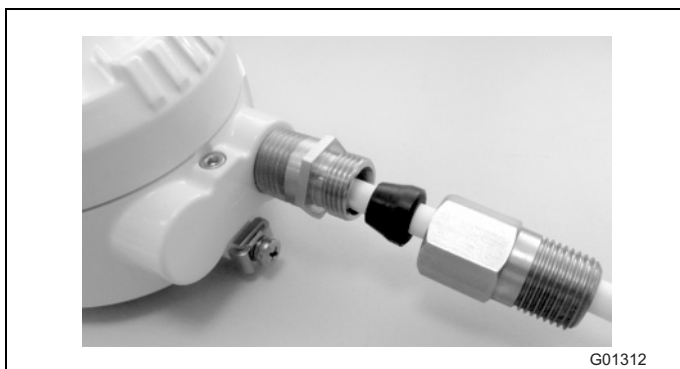

Fig. 45

- | | |
|---|----------------------------------|
| <p>1 Frame application,
e.g., DAT200 Asset Vision Basic
- Communication DTM:
DTM HART Communication ServicePort
- ScanMaster DTM
- Service Port Splitter software</p> | <p>2 FZA100 infrared adapter</p> |
|---|----------------------------------|

10.8 Infrared service port adapter type FZA100**10.9 Installation set for 2" pipe installation in dual-compartment field-mount housing**

Part number: 612B091U07

10.10 Installation set for NPT 1/2" cable gland

Installation set for sealing the cable conduit during outdoor installation.

Part number: 3KXF081300L0001

Trademarks

® HART is a registered trademark of the HART Communication Foundation

® PROFIBUS and PROFIBUS PA are registered trademarks of PROFIBUS & PROFINET International (PI)

® FOUNDATION fieldbus is a registered trademark of the Fieldbus Foundation

™ Hastelloy C-4 is a Haynes International trademark

™ Hastelloy B-3 is a Haynes International trademark

Contact us

ABB Limited

Measurement & Analytics

Howard Road, St. Neots
Cambridgeshire, PE19 8EU
UK

Tel: +44 (0)870 600 6122

Fax: +44 (0)1480 213 339

Mail: enquiries.mp.uk@gb.abb.com

ABB Inc.

Measurement & Analytics

125 E. County Line Road
Warminster, PA 18974
USA

Tel: +1 215 674 6000

Fax: +1 215 674 7183

ABB Automation Products GmbH

Measurement & Analytics

Dransfelder Str. 2
37079 Goettingen
Germany

Tel: +49 551 905-0

Fax: +49 551 905-777

Mail: [vertrieb.messtechnik-
produkte@de.abb.com](mailto:vertrieb.messtechnik-produkte@de.abb.com)

ABB Engineering (Shanghai) Ltd.

Measurement & Analytics

No. 4528, Kangxin Highway, Pudong New District
Shanghai, 201319,
P.R. China

Tel: +86(0) 21 6105 6666

Fax: +86(0) 21 6105 6677

Mail: china.instrumentation@cn.abb.com

www.abb.com/flow

Note

We reserve the right to make technical changes or modify the contents of this document without prior notice. With regard to purchase orders, the agreed particulars shall prevail. ABB does not accept any responsibility whatsoever for potential errors or possible lack of information in this document.

We reserve all rights in this document and in the subject matter and illustrations contained therein. Any reproduction, disclosure to third parties or utilization of its contents - in whole or in parts - is forbidden without prior written consent of ABB.

Copyright© 2018 ABB

All rights reserved

3KXF232500R1001



Sales













Service



Software



Our offering:

	Actuators and Positioners		Analytical Instruments
	Device Management, Fieldbus and Wireless		Flow Measurement
	Force Measurement		Level Measurement
	Natural Gas Measurement		Pressure Measurement
	Recorders and Controllers		Temperature Measurement

HMI – Automação e Instrumentação, Lda.

Travessa da Indústria, nº 111
4780-573 Santo Tirso
PORTUGAL

Tel. +351 252 850 501
Fax. +351 300 013 487

Web: www.hmi.pt

Email: hmi@hmi.pt