



FICHA TÉCNICA DE PRODUTO

PRODUCT DATASHEET

HMI – Automação e Instrumentação, Lda.

Rua dos 5 Caminhos, nº 570
4780-382 Santo Tirso
PORTUGAL

Tel. +351 252 850 501
Fax. +351 300 013 487

Web: www.hmi.pt

Email: hmi@hmi.pt

ABB MEASUREMENT & ANALYTICS | DATA SHEET

AquaProbe FEA100

Insertion-type electromagnetic flow sensor with WaterMaster transmitter



Measurement made easy

Maximum performance,
minimum hassle

Suitable for permanent or temporary installation

- total user flexibility

The most stable transmitter in the world

- self-calibrating transmitter and ultra-low temperature coefficient for highest accuracy

One solution for all your needs

- designed for use in all clean water applications

Quick transmitter exchange

- revolutionary data storage enables transmitter interchange / commissioning without reconfiguration

Advanced infrared service port

- supports simultaneous and parallel operation of HART, remote HMI, cyclic data output and parameter dump

OIML R49 permanent self-checking

- type P approved transmitter
- continuous self-checking of flow sensor and transmitter ensures highest accuracy / long term performance

3-Year material defect warranty (AquaProbe sensor)

'Hot tap' capability

- enables installation with no interruption to water supply

AquaProbe FEA100

The AquaProbe FEA100 extends the capability of the ABB AquaProbe flowmeter by bringing together the proven AquaProbe flow sensor with the innovative WaterMaster transmitter.

AquaProbe has been designed, in close consultation with the water industry, as an economic alternative to full-bore metering. It comprises an electromagnetic sensing head mounted on the end of a support rod. The sensing head can be installed in existing pipelines without the need for the major excavations or alterations to pipework associated with full-bore meters. It can be fitted without interrupting the water supply and can be removed easily for periodic calibration or inspection.

AquaProbe is designed for installation in existing pipelines by means of a small valved tapping. It is normally installed with the sensing head on the pipe centreline, but may be located at the critical position (the mean velocity position) a distance of 1/8 of the pipe diameter away from the wall.

It provides an accurate local measurement of the water velocity and, provided the flow profile is developed fully, a good flow volume measurement.

If the profile is not fully developed, a traverse of the pipe can be performed, enabling an accurate flow volume measurement to be obtained in non-ideal networks.

Key features include the wide flow range with the minimum measured velocity (well below that detected by insertion turbine or DP devices), no moving parts resulting in increased reliability and reduced maintenance.

AquaProbe is ideal for permanent installation to monitor potable or clean water flow. Also through the provision of multiple tappings on the supply pipelines, AquaProbe can be used as a portable survey tool to assist in the building of an accurate network model, locate leaks and check the operation of installed full-bore meters.

The high sensitivity of AquaProbe enables it to traverse the pipe to establish the flow profile and so identify hydraulic problems in complex systems or ensure maximum accuracy from an AquaProbe that has been installed in a non-ideal location.



Figure 1 AquaProbe flow sensor

Based on ABB-proven technology, AquaProbe is supported by the expertise of ABB, the world's leading flow meter manufacturer with many pioneering advances in water flow metering over the last decade – for example, AquaMag™, WaterMaster™, AquaProbe™ and CalMaster™.

ABB operate nationally- and internationally-accredited flow calibration facilities in the UK, Germany, USA, Australia, China and India. We also offer comprehensive, locally based before- and after-sales service.

Comprehensive features

A wide range of features and user benefits are built into WaterMaster as standard:

- bi-directional flow
- unique, self-calibrating transmitter (patent approval in progress) for the ultimate in stability and repeatability
- OIML R49 Type P continuous self-checking transmitter, with alarms, ensures both flow sensor and transmitter accuracy
- true electrode and coil impedance measurement
- comprehensive simulation mode
- universal switch mode power supply (options are available for AC and DC supplies)
- comprehensive self-diagnostics compliant with NAMUR NE107
- programmable multiple alarm capability
- HART protocol over 4 to 20 mA and infrared link
- 3 configurable pulse / frequency and alarm outputs
- advanced infrared service port supports remote HMI, HART, cyclic data out and parameter dump
- read-only switch and ultra-secure service password for total security
- PROFIBUS DP v1 option

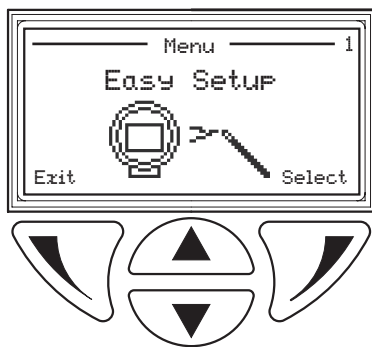

Figure 2 Comprehensive display

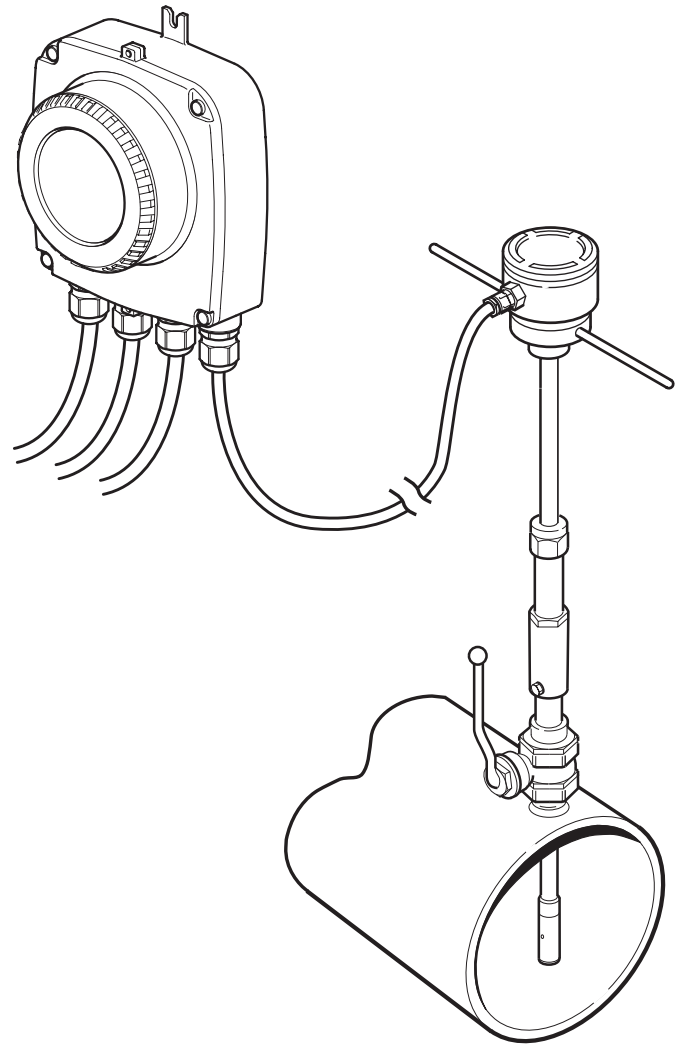

Figure 3 FEA100 remote system

Support software

AquaProbe FEA100 also has on-board remote communication ability, such as interfacing to PROFIBUS DP and HART, that enables the user to collect data remotely.

ABB also supply ScrewDriver, an enhanced software that provides users with all-round improved profile analysis, flow profiling set-up, downloading and display options when used in conjunction with a WaterMaster transmitter.

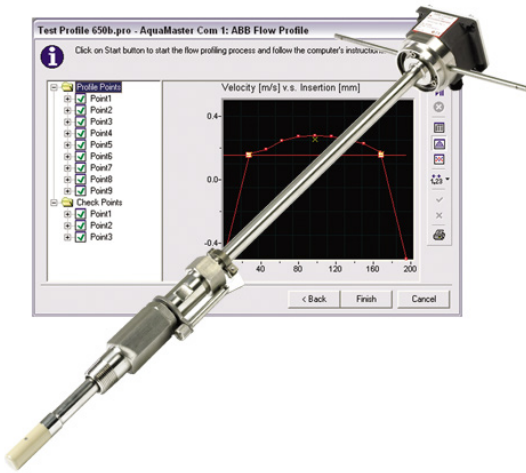

Figure 4 PC software support

Intuitive navigation and configuration

The user-friendly interface enables fast and simple data entry for all parameters. 'Easy Setup' guides the operator step-by-step through the menu to set parameters as quickly as possible, simplifying the commissioning phase.

Improved performance through Digital Signal Processing (DSP)

Advanced Digital Signal Processing (DSP) gives improved performance and enables real-time measurements for maximum reliability.

DSP enables the transmitter to separate the real signal from the noise, providing high quality outputs especially in harsh environments involving vibration, hydraulic noise and temperature fluctuation.

Self-calibration

A unique self-calibration concept developed by ABB (patent pending) has been implemented in AquaProbe FEA100. Compliance with OIML R49 Type P (Permanent) checking requirements requires that electromagnetic flowmeters have 'Checking Facilities', where a simulated signal is fed into the input of the flow transmitter and the output is compared and checked within predetermined limits.

FEA100 has taken this to the next level and uses this signal to not only check the accuracy, but also to perform automatic calibration. This not only meets and exceeds the OIML R49 Type P requirements, it also means the meter has the following features:

- self-calibrating transmitter
- factory calibration no longer necessary
- calibration adjustment is continuous during normal running
- ultra-stable performance with time
- very low temperature coefficient
- the measurement accuracy depends on one precision resistor only
- adjustment % displayed to user for diagnostic use
- alarm limits to trap hardware failures and out-of-range adjustments

Speed, ease and security in the field

'Fit-and-Flow' data storage inside the FEA100 eliminates the need to match flow sensor and transmitter in the field. On initial installation, the self-configuration sequence replicates all calibration factors, meter size and serial numbers into the transmitter automatically, as well as customer site-specific settings, eliminating the opportunity for error.

This redundant storage of data in both the flow sensor and transmitter memory is continually updated during all operations to ensure the integrity of the measurement. An automatic data self-repair routine corrects any data corruption such as totalizer volume corruption that could occur during a power failure.



Figure 5 Transmitter with infrared communications device attached

Detailed diagnostics for rapid decision making

AquaProbe FEA100 is proven to be robust and reliable, with unmatched diagnostic capabilities providing the correct information to keep your process up and running. In accordance with NAMUR NE107, alarms and warnings are classified with the status of 'maintenance required', 'check function', 'failure' and 'out of specification'.

The following screen shows an alarm history with the number of occurrences for the alarm, together with time durations.



Figure 6 Diagnostics display

Advanced infrared service port

As standard, AquaProbe FEA100 incorporates an infrared service port that enables the meter's configuration to be saved externally. If a customer alters the configuration and causes the meter to behave erratically, the infrared service port enables ABB technicians to assist in troubleshooting the problem by enabling easy, remote access to the configuration data.

The infrared service port is used to interrogate HMI menu items automatically and dump the HMI parameter settings and cyclic output measured values (such as flowrate and diagnostic measurement) through the service port to a terminal program. Data can then be downloaded to a PC, saved to a terminal application and output as text or spreadsheet data.

The perfect balance of power, performance, flexibility and control

With AquaProbe, flexibility doesn't mean complicated. Take advantage of its innovative and versatile attributes to achieve interoperability within a wide range of asset management systems.

AquaProbe, the best solution for your flow measurement needs.

Now the best in class is even better!

Easy, low cost installation

No matter what the location or installation requirements, AquaProbe provides a cost-effective solution. The flow sensor is fully submersible, enabling installation in flooded chambers.

The AquaProbe is installed by means of a small valve tapping on the water supply pipeline, normally with the sensing head on the pipe center line. It may be located at the critical position (the mean velocity position) a distance of $\frac{1}{6}$ of the pipe diameter away from the wall.

AquaProbe provides an accurate local measurement of the water velocity and, provided the installation instructions have been carefully followed, a good flow volume measurement.

'Fit and Flow'

- No need to match flow sensor and transmitter
- Fast, reliable installation
- Foolproof, no errors
- Flow sensor stores all calibration factors, site settings, serial numbers and totalizer values
- Totalizer volume values backed-up in flow sensor for total security

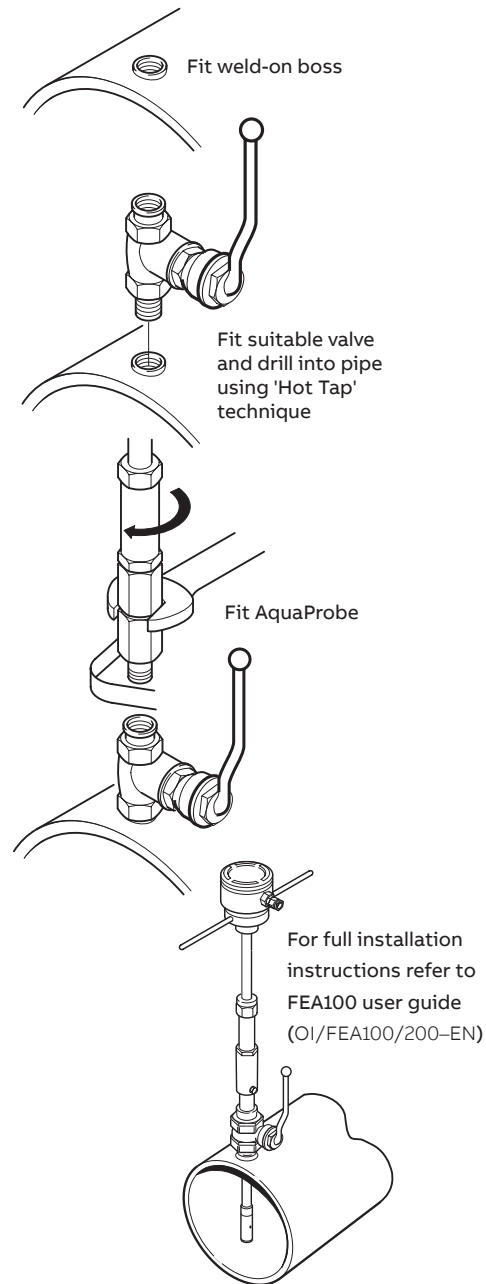

Figure 7 Typical installation (metal pipe)

Technical specification

AquaProbe flow sensor

Maximum insertion length

- 300 mm (12 in.)
- 500 mm (20 in.)
- 700 mm (25 in.)
- 1000 mm (40 in.)

Pipe sizes

200 to 8000 mm (8 to 320 in.) nominal bore

Protection

IP68/NEMA6P (Indefinite submersion down to 10 m [30 ft.])

Weight

<3.5 kg (7.7 lb)

Accuracy

Velocity

- $\pm 2\%$ of Rate or ± 2 mm/s (± 0.08 in./s) whichever is the greater

Volume

- Refer to ISO 7145-1982 (BS 1042 section 2.2) for details

Flow condition

- Fully developed profile in accordance with ISO 7145-1982 (BS1042 section 2.2.)

Max. pressure

20 bar (295 psi)

Pressure equipment directive 97/23/EC

This product is applicable in networks for the supply, distribution and discharge of water and associated equipment and is therefore exempt

Conductivity

>50 $\mu\text{S}/\text{cm}$

Connections

- 1 in. BSP
- 1 in. NPT
- 1.5 in. BSP

Maximum flow

The maximum velocity depends upon the actual insertion length. Typical insertion lengths are 0.125 and 0.5 x pipe diameter.

The graph (Figure 8) is a guide* to the maximum allowable velocity for different insertion lengths.

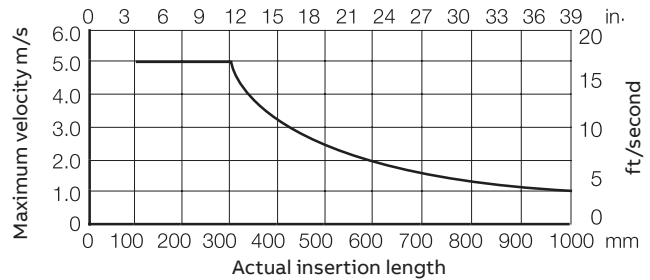

Figure 8 Maximum allowable velocity for different insertion lengths

Warranty

All AquaProbe sensors come with a factory-standard 3-year material defect warranty.

Wetted materials

Body

- Stainless steel

Flow sensor

Suitable for potable water (WRAS listed)

Electrodes – stainless steel 316L

Seals

Suitable for potable water (WRAS listed)

Temperature ranges

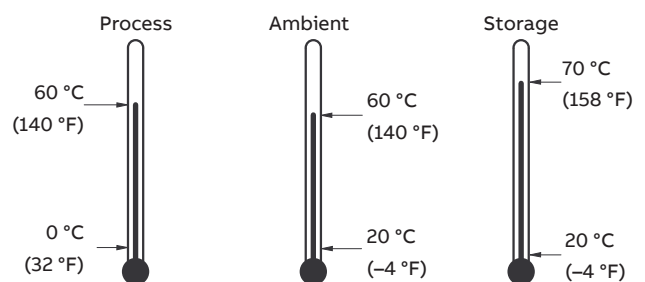

Figure 9 Temperature ranges

Pressure tapping provision

$\frac{1}{8}$ in BSP

*The graph is intended as a guide only. Factors that influence the maximum insertion length into the pipe include: flow sensor mounting components, for example, standoffs, bushes and valves; other influences include pipeline vibration, fluid vibration and pump noise.

...Technical specification

WaterMaster Transmitter

Power supply

Low voltage: 24 V AC +10 %/-30 % @ <7 VA

Mains: 85 to 265 V AC @ <7 VA

DC: 24 V ±30 % @ <0.4 A

Supply voltage fluctuations within the specified range have no effect on accuracy

Digital Outputs (3)

Rating 30 V @ 220 mA, open collector, galvanically isolated

Maximum output frequency 5250 Hz

1 off dedicated to Alarm/ Logic, programmable function

2 off configurable to either Pulse/Frequency or Alarm/ Logic function

Current output – HART FEX100 Variant

4 to 20 mA or 4 to 12/20 mA, galvanically isolated

Maximum loop resistance 750 Ω

HART protocol Version 5.7 (HART registered)

Signal levels compliant with NAMUR NE 43 (3.8 to 20.5 mA)

Low alarm 3.6 mA, High alarm 21.8 mA

Additional accuracy ±0.1 % of reading

Temperature coefficient: typically <±20 ppm/°C

RS485 Communications – PROFIBUS FEX100-DP Variant

Registered name FEX100-DP

RS485 (9.6kbps to 1.5Mbps), galvanically isolated

DPV0, DPV1

PA Profile 3.01

Standard idents: 9700, 9740, 9741

FEX100-DP specific ident: 3431

3 Concurrent MS2 master connections

Electrical connections

20 mm glands, ½ in NPT, 20 mm armored glands

Flow sensor cable length

5, 10, 20, 30, 50, 80, 100, 150 m

(16, 33, 65, 98, 164, 263, 329, 492 ft)

Temperature limitations

Temperature coefficient: typically

<±10 ppm/°C @ Vel ³0.5 m/s

Ambient temperature: -20 to 60 °C (-4 to 140 °F)

Environmental protection

Humidity: 0 to 100 %

Rating: IP67 (NEMA 4X) to 1 m (3.3 ft) depth

Tamper-Proof Security

Write access prevented by internal switch combined with external security seals for secure applications

Languages

English, French, German, Italian, Spanish, Polish

Infrared service port

USB adapter (accessory), USB 1.1. and 2.0 compatible

Driver software for Windows 2000, XP, Vista and

Windows 7

Housing material

Powder-coated aluminium with glass window

Probe limits of upstream disturbance

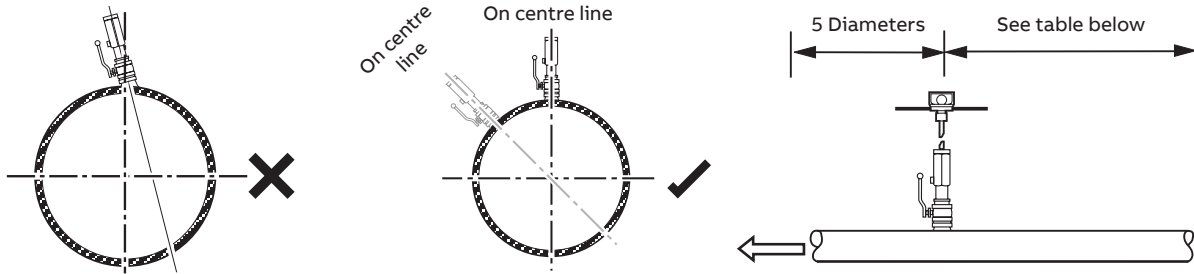

Type of disturbance upstream from the measuring cross-section	Minimum upstream straight length*	
	For a measurement at the point of mean axial velocity	For a measurement on the axis of the conduit
90° Elbow or a T-bend	50	25
Several 90° Coplanar Bends	50	25
Several 90° Non-coplanar Bends	80	50
Total Angle Convergent 18 to 36°	30	10
Total Angle Divergent 14 to 28°	55	25
Fully Opened Butterfly Valve	45	25
Fully Opened Plug Valve	30	15

*Expressed in multiples of the diameter of the conduit.

Downstream from the measurement cross-section, the straight length must be at least equal to five duct diameters whatever the type of disturbance.

Note. This Table is an extract from ISO7145 (BS 1042): Section 2.2: 1982 and is reproduced with the permission of BSI. Complete copies of the standard can be obtained by post from BSI Publications, Linford Wood, Milton Keynes, MK14 6LE.

Electrical connections

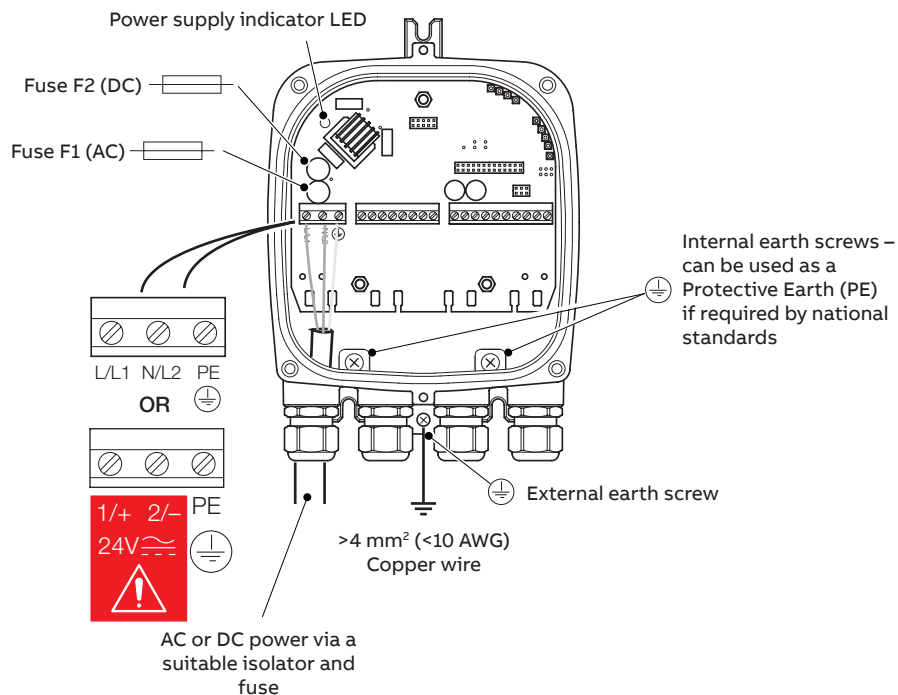

Overall dimensions

Flow sensor

Dimensions in mm (in.)

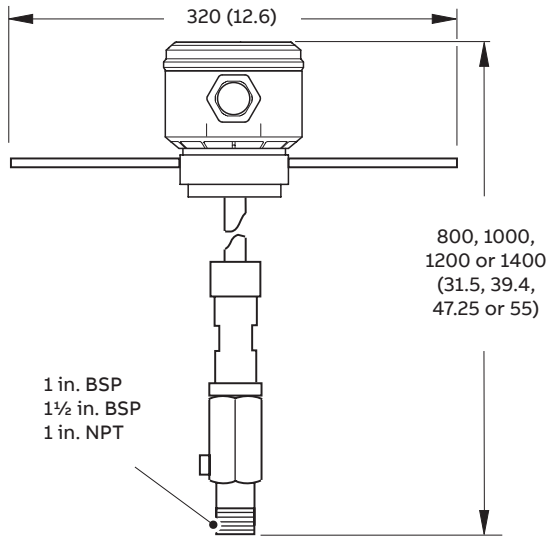

Terminal box – flow sensor-mounted

Dimensions in mm (in.)

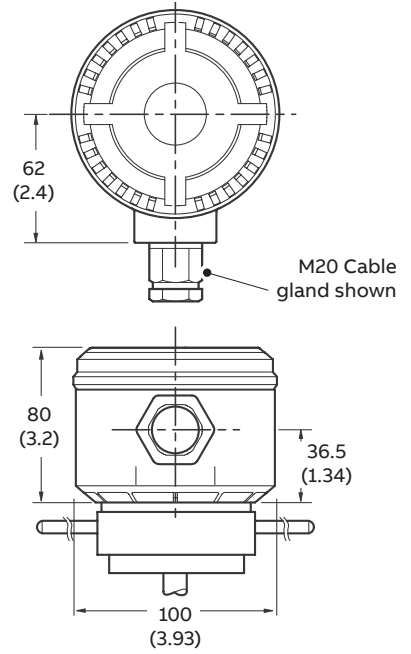

Remote transmitter

Dimensions in mm (in.)

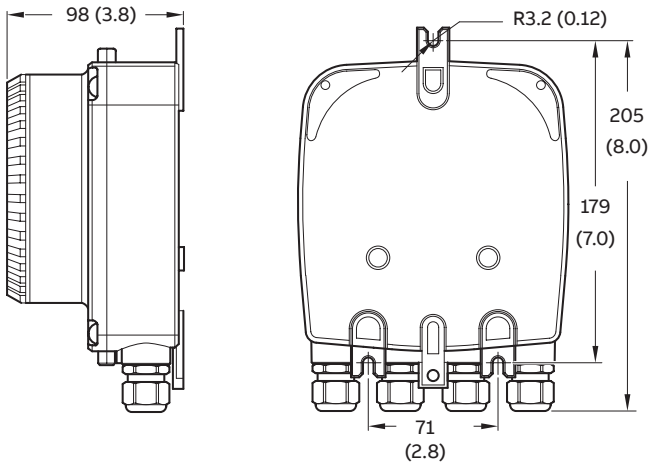

Trademarks and acknowledgements

HART is a registered trademark of the HART Communication Foundation

Microsoft Excel™, Windows XP™, Vista™ and Windows 7™ are registered trademarks of the Microsoft Corp.

PROFIBUS™ is a registered trademark of PROFIBUS corporation.

Sales



Service



Software



ABB Limited
Measurement & Analytics

Oldends Lane
Stonehouse
Gloucestershire GL10 3TA
UK

Tel: +44 (0)1453 826 661

Fax: +44 (0)1453 829 671

Mail: instrumentation@gb.abb.com

ABB Engineering (Shanghai) Ltd.
Measurement & Analytics

No. 4528, Kangxin Highway,
Pudong New District
Shanghai, 201319,
P.R. China

Tel: +86(0) 21 6105 6666

Fax: +86(0) 21 6105 6677

Mail: china.instrumentation@cn.abb.com

ABB Limited
Measurement & Analytics

125 E. County Line Road
Warminster PA 18974
USA

Tel: +1 215 674 6000

Fax: +1 215 674 7183







abb.com/measurement

We reserve the right to make technical changes or modify the contents of this document without prior notice. With regard to purchase orders, the agreed particulars shall prevail. ABB does not accept any responsibility whatsoever for potential errors or possible lack of information in this document.

We reserve all rights in this document and in the subject matter and illustrations contained therein. Any reproduction, disclosure to third parties or utilization of its contents – in whole or in parts – is forbidden without prior written consent of ABB.



Our offering:

	Actuators and Positioners		Analytical Instruments
	Device Management, Fieldbus and Wireless		Flow Measurement
	Force Measurement		Level Measurement
	Natural Gas Measurement		Pressure Measurement
	Recorders and Controllers		Temperature Measurement

HMI – Automação e Instrumentação, Lda.

Rua dos 5 Caminhos, nº 570
4780-382 Santo Tirso
PORTUGAL

Tel. +351 252 850 501
Fax. +351 300 013 487

Web: www.hmi.pt

Email: hmi@hmi.pt