



FICHA TÉCNICA DE PRODUTO

PRODUCT DATASHEET

---

HMI – Automação e Instrumentação, Lda.

---

Rua dos 5 Caminhos, nº 570  
4780-382 Santo Tirso  
PORTUGAL

Tel. +351 252 850 501  
Fax. +351 300 013 487

Web: [www.hmi.pt](http://www.hmi.pt)

Email: [hmi@hmi.pt](mailto:hmi@hmi.pt)

# VA Master FAM540 Metal Cone Variable Area Flowmeter

Measurement made easy



For measuring liquids, gases and steam

Graphical 2-line LCD display

**Magnet stick operation**

- Configuration also possible with closed housing

Easily adjustable for new operating conditions

**Approvals for explosion protection**

- ATEX
- IECEx
- FM, CSA

# VA Master FAM540

## Metal Cone Variable Area Flowmeter

### Overview

Model	FAM541	FAM544	FAM545	FAM546
	Standard design  G10448	Hygienic design  G10449	With PTFE liner  G10450	With heating jacket  G10451
Measured error in accordance with VDE / VDI 3513	1.6 % qg = 50 %	1.6 % qg = 50 %	2.5 % qg = 50 %	1.6 % qg = 50 %
Reproducibility	0.25 % of measured value	0.25 % of measured value	0.25 % of measured value	0.25 % of measured value
Process connection	Flange in accordance with DIN, ASME, JIS, female thread	Thread DIN 11851, SMS 1145	Flange in accordance with DIN, ASME, JIS	Flange in accordance with DIN, ASME, JIS
Nominal connection diameters	DN 15 (1/2") ... DN 100 (4")	DN 25 (1") ... DN 100 (4")	DN 25 (1") ... DN 100 (4")	DN 25 (1") ... DN 100 (4")
Maximum measuring medium temperature	400 °C (752 °F)	140 °C (284 °F)	120 °C (248 °F)	400 °C (752 °F)
Maximum pressure rating	PN 400 / class 2500	PN 40	PN 40 / class 300	PN 100 / class 600
Wetted material	Stainless steel 1.4404 (316L), 1.4571 (316Ti)	Stainless steel 1.4404 (316L), 1.4571 (316Ti)	PTFE	Stainless steel 1.4404 (316L), 1.4571 (316Ti)
Housing material	Stainless steel 1.4404 (316L), 1.4571 (316Ti)	Stainless steel 1.4404 (316L)	Stainless steel 1.4571 (316Ti)	Stainless steel 1.4404 (316L), 1.4571 (316Ti)
Gasket material	Viton A (DN 15 only)	Viton A (DN 25 only)	PTFE	Viton A (DN 25 only)

#### Indicator / transmitter

IP degree of protection in accordance with EN 60529	IP66, IP67, NEMA 4X
Mechanical indicator	Analog indicator with or without alarm signaling unit
Electronic indicator	Analog indicator with transmitter 4 ... 20 mA, with or without LCD indicator
Communication	HART protocol (only for analog indicators with transmitters)
Power supply	Without alarm signaling unit: no power supply Analog indicator with alarm signaling unit: 8 V DC via switch amplifier Analog indicator with transmitter: 10 ... 46 V DC (Ex: 10 ...30 V DC)
Indicator housing material	Al Si 12 material number 3.2582 (copper content 0.1 %), stainless steel 1.4408
Paint	Epoxy paint 80 ... 100 µm; Bottom color: RAL 7012, cover color: RAL 9002 (No housing paint for stainless steel indicator housing)

#### Approvals

Ex-approvals	ATEX / IECEx: Zone 0 / 1 / 2 / 21 FM / cCSAus: XP, IS, DIP, NI, FM Zone 1 + 2
Sealing concept	Dual sealing in accordance with ANSI / ISA-12.27.01
SIL approval (not for FAM545)	Analog indicator with alarm signaling unit: SIL 2 Analog indicator with transmitter: FMEDA evaluation

## Introduction and basics

### Installation conditions

- The installation recommendations of VDI / VDE Directive 3513 must be observed.
- The flowmeter is installed vertically in the piping. The measuring media must flow from bottom to top.
- Keep the device as far as possible from pipe vibrations and powerful magnetic fields.
- The piping should be the same size as the connection size of the flowmeter.
- Inlet and outlet sections are generally not required. Care should be taken to avoid flow turbulence, pulsations, pressure shocks and other flow instabilities in order to prevent measuring inaccuracies, increased wear or damage.
- When selecting devices, pay close attention to the chemical resistance of the wetted parts of the device and the process connection gaskets in relation to the measuring medium.
- Avoid pulsating flow of the measuring medium. Use the optional float damping if necessary.
- For gaseous measuring media we recommend an undisturbed inlet length of five times the inside diameter of the piping in accordance with VDI / VDE Directive 3513 sheet 3. Additional measures such as flow straighteners or perforated plates may be necessary for highly unbalanced flow profiles.
- Avoid contamination of gaseous measuring media (refer to BGR 132-7.3.2.2.2).
- For liquid measuring media, the nominal size of the piping should be dimensioned as large as possible (if economically viable).
- Avoid gas inclusions in liquid measuring media.
- Use slow opening valves.
- If the flowmeter is installed in a pipeline where decommissioning is impossible or inexpedient, a bypass line should be provided.
- Shut-off and throttle valves should preferably be attached to the outlet of the flowmeter.

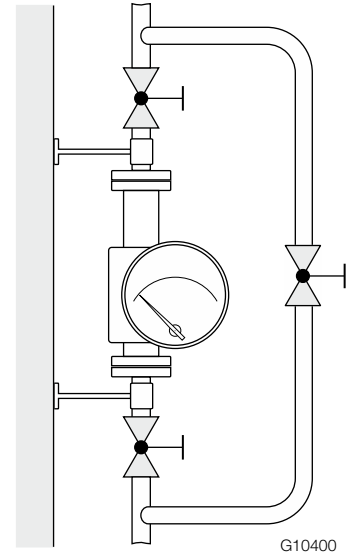

**Fig. 1: Installation of the flowmeter (example)**

Refer to VDI/VDE Directive 3513 sheet 3, Selection and Installation Recommendations for Variable Area Flowmeters.

### Sensor insulation

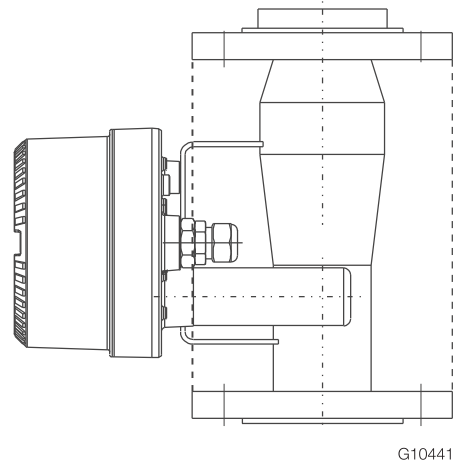

**Fig. 2: Insulation of the flowmeter**

As shown in Fig. 2, the flowmeter may only be insulated up to the flange diameter.

# VA Master FAM540

## Metal Cone Variable Area Flowmeter

### Operating conditions

A variable area flowmeter is specified for a defined set of operating conditions of the measuring medium. For liquids and gases, these are pressure and temperature-related properties (density and viscosity) under operating conditions.

For gases, in particular, this means operating at a specific operating pressure and operating temperature. The specified accuracy of the device always refers to the operating conditions underlying the specification.

### Temperature data

The following diagram shows the maximum permissible measuring medium temperature depending on the ambient temperature.

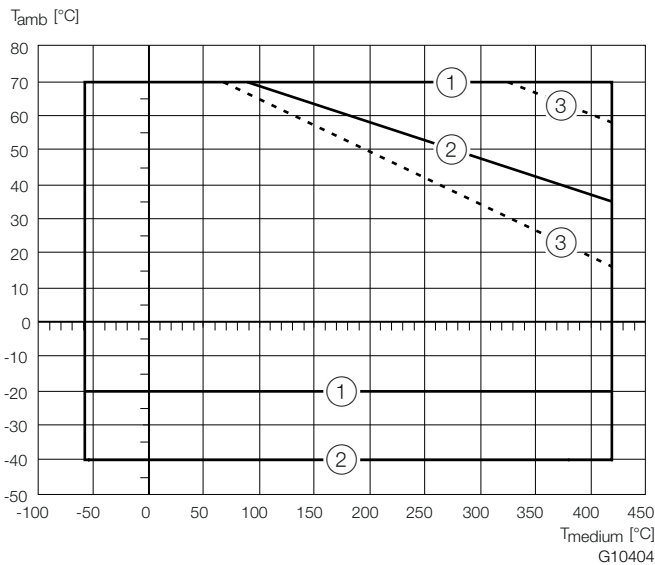

Fig. 3: Medium temperature ( $T_{\text{medium}}$ ), ambient temperature ( $T_{\text{amb}}$ )

- ① Devices with alarm output -20 ... 70 °C (-4 ... 158 °F)
- ② Devices with current output -40 ... 70 °C (-40 ... 158 °F)
- ③ With insulation

### NOTE

When using in potentially explosive atmospheres, observe the temperature information in the ATEX / IECEx limit values starting from „Safety specifications ATEX / IECEx“ on page 34 and the FM / cCSAus limit values tables starting from „Safety specifications FM, cCSAus“ on page 43!

### Pressure loss

The available operating pressure at the measuring point must be higher than the pressure loss listed for the flowmeter in the specifications.

It is important to also consider the pressure loss downstream from the flowmeter due to losses in the piping and other fittings.

### Prevention of compression oscillations when measuring gases

With low flow amounts and low operating pressure, so-called compression oscillations of the float can occur.

If the maximum upstream pressure listed in the specifications is not reached, the flowmeter can optionally be equipped with a gas damper.

To prevent self-generated compression oscillations, note the following information from VDI / VDE 3513 Sheet 3:

- Select a flowmeter with the lowest possible pressure loss.
- Minimize the piping length between the flowmeter and the closest up or downstream throttling location.
- Restrict the usual measuring range from the usual 10 ... 100 % to 25 ... 100 %.
- When setting the flow rate value, always start assuming larger values.
- Increase the operating pressure and consider its effect on the flow rate values due to the change in gas density at the new operating conditions.
- Minimize non-throttled, free volumes upstream and downstream of the device.

### Pressure shocks

Especially when measuring gases, it is possible that pressure or shock waves can occur when fast opening solenoid valves are employed and the piping cross-sections are not throttled, or if there are gas bubbles in liquids.

As a result of the sudden expansion of the gas in the piping, the float is forcibly driven against the upper floatstop.

Under certain conditions, this can lead to destruction of the device.

Gas damping is not suited to compensating for pressure shocks!

### Solids content in the measuring medium

Variable area flowmeters have only limited suitability for measuring media containing solids.

Depending on the concentration, particle size and type of solid, increased mechanical abrasion may occur, especially at the critical measuring edge of the float.

In addition, solidified deposits on the float can change its weight and shape.

These effects can lead to erroneous measurement results, depending on the float type.

In general, the use of appropriate filters is recommended in such applications.

For the flow measurement of measuring media containing magnetic particles, we recommend the installation of a magnetic separator upstream of the variable area flowmeter.

### Float designs

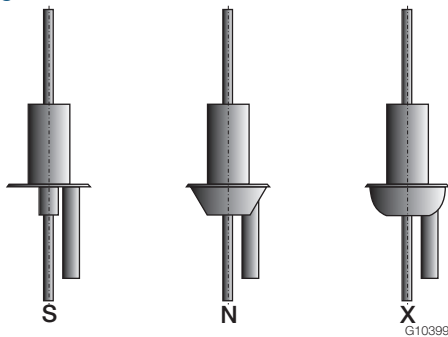

Fig. 4: Float designs

#### Float "S":

Basic shape of float.

Low flow rates, minimal pressure losses, essentially independent of viscosity; lower upstream pressure required for gas measurement.

#### Float "N":

Higher flow ranges, average pressure losses, well suited to liquids with minimum viscosity; higher minimum upstream pressure requirements for gas measurements.

#### Float "X":

Highest flow rates, maximum pressure losses, well suited to liquids with minimum viscosity; higher minimum upstream pressure requirements for gas measurements.

### Measuring range limits

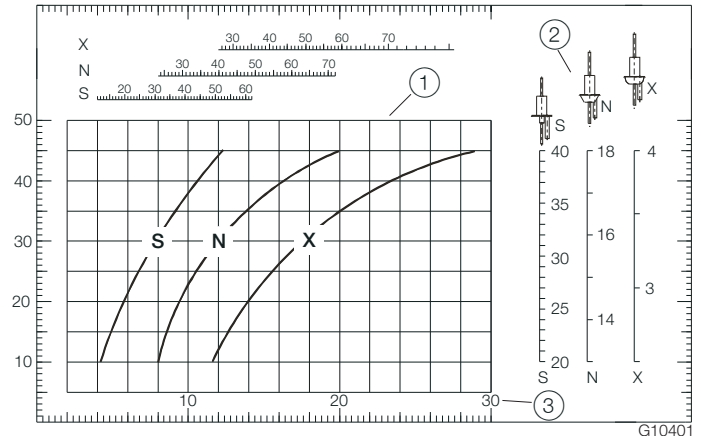

Fig. 5: Flow rate depending on float shape and weight (example)

- ① Pressure loss (dP in mbar)
- ② Diameter of the float weight (mm)
- ③ x 1000 l/h water

For measuring range limits depending on nominal size and float type, refer to the measuring range tables.

### Calculating the viscosity influence number (VIN)

The floats are designed geometrically so as to be independent of viscosity within broad limits. This means that the measuring medium viscosity can vary within these limits without resulting in a change of scale.

The viscosity influence number (VIN) is given in the device measuring range tables.

- If the calculated VIN is greater than the listed VIN, viscosity has no influence on the measurements.
- If the calculated VIN is greater than the listed viscosity, the flowmeters are equipped from the factory with a scale adjusted to the viscosity.

$$VIN = \eta \cdot \sqrt{\frac{(\rho_s - 1) \cdot 1}{(\rho_{s1} - \rho_1) \cdot \rho_1}}$$

#### Legend

$\eta$	Dynamic viscosity of the measuring medium [mPa s]
$\rho_s$	Density of the float in accordance with the selection in the measuring range table ( $r = 8.02 \text{ g/cm}^3$ )
$\rho_{s1}$	Density of the float being used
$\rho_1$	Density of the measuring medium

# VA Master FAM540 Metal Cone Variable Area Flowmeter

## Indicator and transmitter

A magnet in the float translates the height of the float as a measurement for the flow to the decouple-proof magnet follower system of the flowmeter, which is directly connected to the indicator pin.

For analog indicators, the flow value is shown by the indicator on the scale. For indicators with a two-wire transmitter, the indicator position is additionally measured directly at the axis. A standard eddy-current brake is used to dampen indicator vibrations and ensure outstanding readability.

The indicator/transmitter unit is attached to the flowmeter with 2 screws in a reproducible manner. To facilitate installation, the indicator can be removed. A name plate on the flowmeter bracket allows you to assign a unique identifier at a later date.

### Analog indicator with or without alarm signaling unit

The analog indicators are available with or without an alarm signaling unit. The alarm signaling units are housed on an alarm module that can also be retrofitted. It is available as a single (min. or max. alarm) or dual (min. or max. alarm) alarm module.

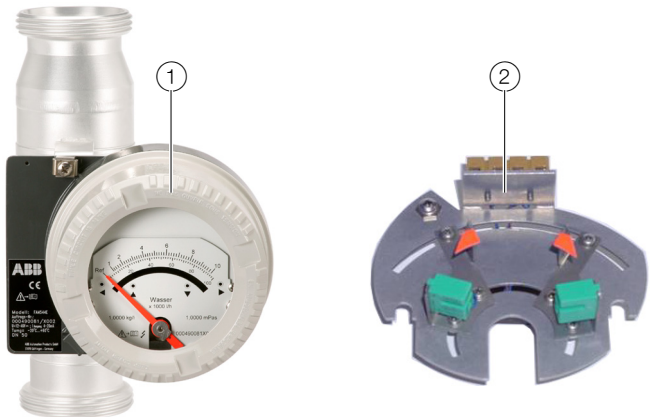

G10452

**Fig. 6: Analog indicator**  
① Analog indicator ② Alarm module (option)

## Product highlights

- Decouple-proof and hysteresis-free magnet follower system.
- The device conforms to NAMUR Recommendations NE43, NE53, NE107.
- Installing and uninstalling the analog indicator on the meter tube is possible without opening the indicator housing.
- Reading repeatability:  $\pm 0.25\%$  of scale end value.
- The alarm signaling unit can be retrofitted as an alarm module.
- The switching points of the alarm signaling units are adjustable without removing the scale.
- The set switching points of the alarm signaling units are visible from the exterior.

## Alarm signaling unit

Additional switching amplifiers are needed to operate the alarm signaling units.

See chapter „Ordering Information“ on page 50 for further information.

### Alarm signaling unit specifications

Operating mode	bistable
Reproducibility	$\pm 0.5\%$ of scale end value
Nominal voltage	8 V DC (Ri approx. 1 k $\Omega$ )
Operating voltage	5 ... 25 V DC
Switching frequency, max.	3 kHz

## Switching amplifier

For analog indicators with alarm signaling units (model FAM54xB/C/Dx)

### Specifications

Power supply	230 V AC, +10 % / -15 %, 45 ... 60 Hz 115 V AC, +10 % / -15 %, 45 ... 60 Hz 24 V DC, +10 % / -15 %
Output	1 or 2 switching relays with potential-free changeover contacts
Switching capacity	Maximum 250 V, maximum 4 A, maximum 500 VA
Maximum permissible cable length	Between switch amplifier and alarm signaling unit: 300 m (984 ft)
Permissible ambient temperature	-20 ... 60 °C (-4 ... 140 °F)
Electrical connection	Screw terminals, maximum 2.5 mm <sup>2</sup> (14 AWG)
Type of assembly	35 mm top-hat rail in acc. with EN 60715:2001
IP rating	IP20 in accordance with EN 60529
Weight	Approx. 150 g (0.3 lb)

### Analog indicator with transmitter

The electronic transmitter uses two-wire technology. An optional LCD indicator offers the possibility of adjusting on-site to changed measuring medium parameters.

For models with an LCD indicator, ABB recommends that you use a bar graph scale to avoid differences between a product scale and the flow rate shown on the LCD indicator.

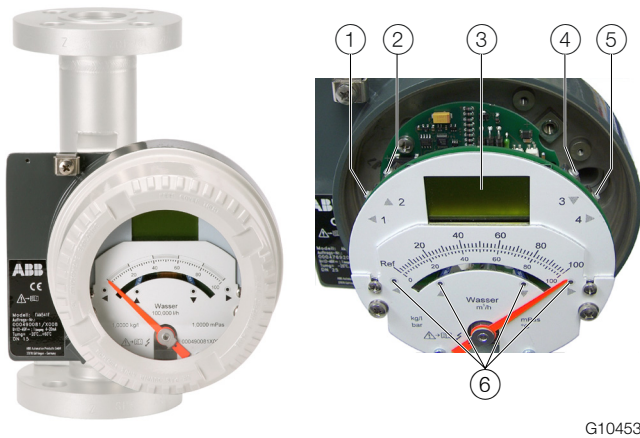

Fig. 7: LCD indicator with operating buttons and magnet stick markings

- ① ◀ button    ② ▶ button    ③ LCD indicator    ④ ▼ button  
⑤ ▲ button    ⑥ Dots for magnet stick operation

### Product highlights

- 4 ... 20 mA current output.
- Current output for an alarm can be configured to 21 ... 23 mA (NAMUR NE43).
- Programmable binary output (min. / max. device alarm, general alarm or pulse output).
- Parameterization using HART communication via handheld terminal or DSV401 (SMART VISION).
- Damping: 1 ... 100 s configurable (5  $\tau$ ).
- Low flow cut-off: 0 ... 5 % for current and pulse output.
- Measuring medium parameters can be changed at any time (pressure and temperature influence, density, units, etc.).
- Simulation of current and binary output (manual process execution).
- EEPROM storage of counter readings and parameters specific to the measuring point (over 10 years).
- LCD indicator can be retrofitted.

### LCD indicators

- High-contrast LCD indicator.
- Flow rate and flow totalizer value display.
- Plain text fault diagnostics
- Menu-guided parameterization with four buttons.
- Parameterization of the device using a magnet stick without opening the housing.



# VA Master FAM540

## Metal Cone Variable Area Flowmeter

### Electrical connections

#### NOTE

When using in potentially explosive atmospheres, observe the electrical data in the ATEX / IECEx limit value tables starting from „Safety specifications ATEX / IECEx“ on page 34 and the FM / cCSAus limit value tables starting from „Safety specifications FM, cCSAus“ on page 43!

#### Analog indicator with alarm signaling unit Model FAM54xB/C/Dx

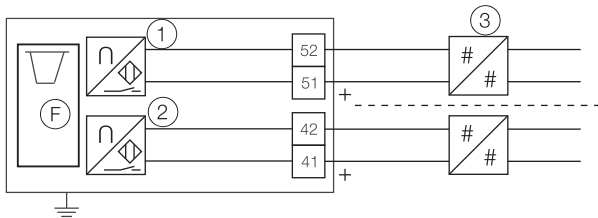

Fig. 8: Alarm signaling unit

- ① Maximum alarm signaling unit ② Minimum alarm signaling unit  
③ Switch amplifier (F) Flowmeter

#### Alarm signaling unit specifications

Operating mode	bistable
Reproducibility	±0.5% of scale end value
Nominal voltage	8 V DC (R <sub>i</sub> approx. 1 kΩ)
Operating voltage	5 ... 25 V DC
Switching frequency, max.	3 kHz

#### Analog indicator with transmitter Model FAM54xE/Fx

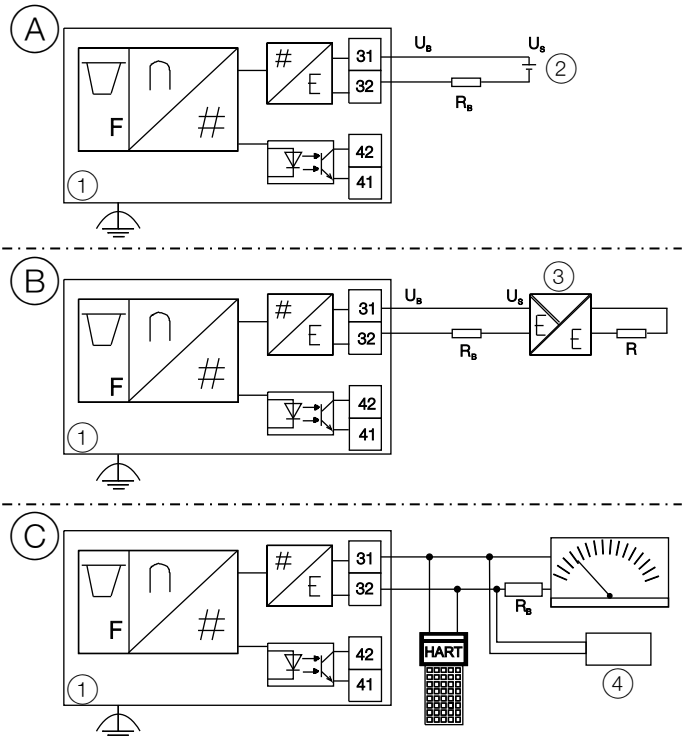

Fig. 9: Analog indicator with transmitter

- ① Flowmeter ② Power supply ③ Power supply unit  
④ HART modem

#### Legend

U <sub>B</sub>	Operating voltage
U <sub>S</sub>	Input terminal voltage
R <sub>B</sub>	Maximum permissible load for power supply unit (e.g. indicator)
R	Maximum permissible load for output circuit; is determined by power supply unit
	Functional earth

## Cables

Maximum cable length 1500 m, AWG 24 twisted and shielded.

## Power supply / current output

Terminals 31 / 32 serve both as a connection for the power supply and as a 4 ... 20 mA current output for the transmitter. The current output is also used for HART communication.

Power supply	
Terminals	31 / 32
Voltage	Standard: 10 ... 46 V DC Explosion-proof design: 10 ... 30 V DC.
Residual ripple	Maximum 5 % or $\pm 1.5 V_{SS}$
Power consumption	< 1 W

Current output	
Terminals	31 / 32
Output	4 ... 20 mA, can be configured to 21 ... 23 mA for an alarm (in accordance with NAMUR NE43)
Load	Minimum > 250 $\Omega$ , maximum 1500 $\Omega$ (for I at alarm = 23.0 mA)
Temperature effect	$\leq 8 \mu A/K$
Power consumption	< 1 W

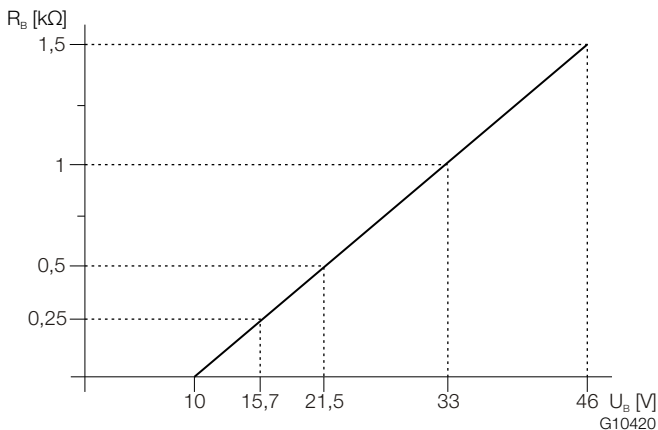

Fig. 10: Load diagram of the current output

## HART output

### Model FAM54xE/Fx

Specifications	
Terminals	31 / 32
Configuration	– Directly on the device – Using DAT200 Asset Vision Basic software and HART-DTM
Transmission	FSK modulation on current output 4 ... 20 mA in accordance with Bell 202 standard
Baud rate	1200 baud
Display	Logic 1: 1200 Hz Logic 0: 2200 Hz
Maximum signal amplitude	1.2 mA <sub>SS</sub>
Load (RB) at current output	250 ... 1500 $\Omega$

See the separate interface description for detailed information.

## System integration

In conjunction with the DTM (Device Type Manager) available for the device, the corresponding framework applications in accordance with FDT 0.98 or 1.2 (DAT200 Asset Vision Basic) can be used for communication (configuration, parameterization). Other tool/system integrations (e.g., Emerson AMS/Siemens PCS7) are available on request. The necessary DTMs and additional files can also be downloaded from [www.abb.com/flow](http://www.abb.com/flow).

## Programmable binary output

Terminals 41 / 42 are used as a primary programmable binary output. The pulse output, general alarm, min./max. alarm and general alarm functions, as well as "no function" can be configured using the software.

Binary output	
Terminals	41 / 42
Output	– NAMUR contact (DIN 19234) or – Standard optoelectronic coupler ( $U_H = 16 \dots 30$ V DC)
Switching behavior	Configurable as normally closed or normally open contacts
Internal resistance	With contact open > 10 k $\Omega$
Switching current	Maximum 15 mA
Output voltage	Minimum $U_o$ 2 V DC

## Pulse output

Terminals	41 / 42
Pulse width	5 ... 256 ms, maximum 50 % of the period
Frequency $f_{max}$	Maximum 50 Hz

# VA Master FAM540

## Metal Cone Variable Area Flowmeter

### Model FAM541 - Standard design



G10448

Fig. 11: Model FAM541

#### Scale

Design optionally with percentage scale or product scale.

#### Gas damping

Option, for preventing compression oscillations in case of gas measurements with low operating pressure.

#### SIL approval

- SIL2 declaration of conformity for devices with alarm function.
- Manufacturer's declaration (SIL1) in accordance with IEC 61508 / IEC61511 for devices with a current output of 4 ... 20 mA.

#### Measuring accuracy

1.6 % qg = 50 % in accordance with VDE / VDI 3513, sheet 2, optional 1 % of upper range value.

#### Measuring range limits and span limits

Measuring span: 10:1

For detailed information about measuring ranges, see chapter „Measuring range table“ on page 12.

#### Temperature limits °C (°F)

##### Medium temperature range

- -55 ... 400 °C (-67 ... 752 °F)

##### Ambient temperature range

- -40 ... 85 °C (-40 ... 185 °F)

#### NOTE

- When using in potentially explosive atmospheres, observe the temperature information in the ATEX / IECEx limit values starting from 34 and the FM / cCSAus limit values tables starting from „Safety specifications FM, cCSAus“ on page 43!
- Also observe the information in chapter „Temperature data“ on page 4!

#### Process connections

- Flange in accordance with EN 1092-1 (PN 16, PN 40)
- Flange in accordance with DIN 2501 (PN 63, PN 100)
- Flange with groove in accordance with DIN 2501
- Flange in accordance with ASME B16.5
- G 1" female thread (1/2" meter tube)
- G 1 1/2" female thread (1" meter tube)

#### Pressure ratings

- Standard pressure rating: PN 40 (PN 16 for DN 100 [4"])
- Flange in accordance with DIN / EN: PN 16, PN 40, PN 63, PN 100
- Flange in accordance with ASME: CL 150, CL 300, CL 600

Other designs and pressure ratings are available upon request.

See chapter „Material load“ on page 11.

#### Maximum permissible operating pressure

64 bar, 100 bar, 160 bar, 250 bar  
(CL 600 /CL 900 /CL 1500 / CL 2500)

## Materials

### Materials for the indicator housing

Component	Material
Indicator housing	Standard: aluminum, powder-coated Option: stainless steel 1.4408
Powder coating	Epoxy paint 80 ... 100 µm Bottom color: RAL 7012 Cover color: RAL 9002
Housing gasket (O-ring)	Buna N®
Sight glass	Shatterproof glass

### Materials for wetted parts

Component	Material
Meter tube	Stainless steel 1.4404 (316 L)
Conical meter pipe	Stainless steel 1.4571 (316 Ti), only DN 15 (1/2")
Flange	Stainless steel 1.4404 (316 L)
Variable area	Standard: stainless steel 1.4571 (316 Ti), Option: stainless steel 1.4571 (316 Ti)
Gas damping (option)	Stainless steel 1.4571 (316 Ti)

## Material load

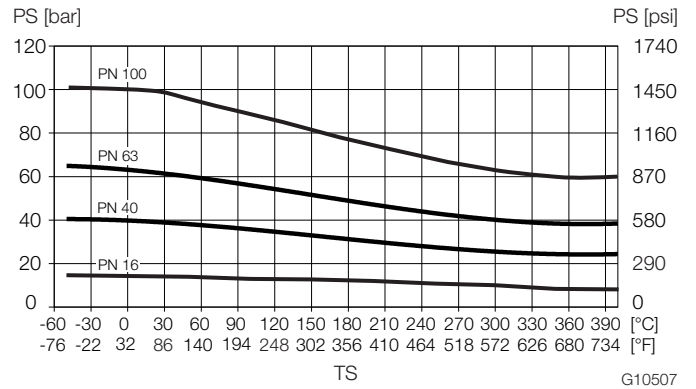

Fig. 12: DIN flange made from stainless steel

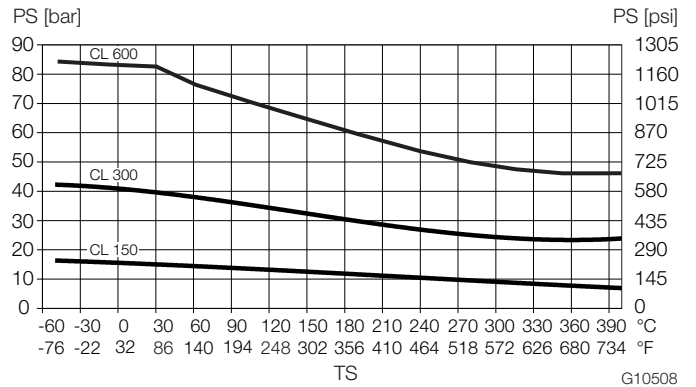

Fig. 13: ASME flange made from stainless steel

# VA Master FAM540

## Metal Cone Variable Area Flowmeter

### Measuring range table

#### NOTE

The "FlowCalc" program, which is available as a free download from [www.abb.com/flow](http://www.abb.com/flow), can be used to calculate flow rates, pressure losses, and upstream pressure requirements.

The data listed applies to water at 20 °C (68 °F), 1 kg/dm<sup>3</sup> (62.43 lb/ft<sup>3</sup>), 1 mPas (1 cP) and to air at 0 °C (70 °F), 1013 mbar (14.7 psia).

DN <sup>1)</sup>	Upper range value <sup>2)</sup> for		Meter tube / nominal flow rate H <sub>2</sub> O [l/h] / Order code <sup>3)</sup>	VIN <sup>4)</sup>	Pressure loss <sup>5)</sup> [mbar (psi)]	Minimum upstream pressure for gas measurement <sup>6)</sup>	
	Water [l/h (USgal/h)]	Air [m <sup>3</sup> /h (scfh)]				Without gas damping [bar abs (psia)]	With gas damping <sup>7)</sup> [bar abs (psia)]
DN 15 (1/2")	28 ... 32 (7.4 ... 8.5)	0.83 ... 0.95 (37 ... 45)	1/2" / 30 / A7 <sup>8)</sup>	6	80 (1.16)	4.0 (58.02)	1.0 (14.5)
DN 25 (1")	37 ... 43 (10 ... 11.4)	1.10 ... 1.28 (52 ... 59)	1/2" / 40 / B7 <sup>8)</sup>	6	80 (1.16)	4.0 (58.02)	1.0 (14.5)
	44 ... 55 (11.6 ... 14.5)	1.30 ... 1.63 (54 ... 66)	1/2" / 50 / C7 <sup>8)</sup>	6	80 (1.16)	4.0 (58.02)	1.0 (14.5)
G1"	56 ... 64 (14.5 ... 17)	1.66 ... 1.90 (68 ... 80)	1/2" / 60 / D7 <sup>8)</sup>	6	80 (1.16)	4.0 (58.02)	1.0 (14.5)
	77 ... 83 (20.5 ... 21.5)	2.29 ... 2.47 (84 ... 90)	1/2" / 80 / E7	16	40 (0.58)	3.0 (43.51)	1.0 (14.5)
	96 ... 104 (25.5 ... 27)	2.85 ... 3.09 (104 ... 112)	1/2" / 100 / F7	16	45 (0.65)	3.2 (46.41)	1.0 (14.5)
	115 ... 125 (30 ... 33)	3.42 ... 3.72 (125 ... 135)	1/2" / 120 / G7	16	50 (0.73)	3.5 (50.76)	1.0 (14.5)
	144 ... 156 (38 ... 41)	4.28 ... 4.64 (155 ... 165)	1/2" / 150 / H7	16	60 (0.87)	3.8 (55.11)	1.0 (14.5)
	188 ... 212 (50 ... 56)	5.59 ... 6.30 (205 ... 230)	1/2" / 200 / J7	16	60 (0.87)	4.0 (58.02)	1.0 (14.5)
	235 ... 265 (62 ... 70)	6.98 ... 7.88 (255 ... 285)	1/2" / 250 / K7	16	65 (0.94)	4.2 (60.92)	1.0 (14.5)
	282 ... 318 (74 ... 84)	8.38 ... 9.45 (310 ... 340)	1/2" / 300 / L7	16	70 (1.02)	4.4 (63.82)	1.0 (14.5)
	376 ... 424 (100 ... 112)	11.17 ... 12.60 (410 ... 460)	1/2" / 400 / M7	16	75 (1.09)	4.6 (66.72)	1.0 (14.5)
	470 ... 530 (125 ... 140)	13.97 ... 15.75 (510 ... 570)	1/2" / 500 / N7	16	75 (1.09)	4.8 (69.62)	1.0 (14.5)
	565 ... 635 (150 ... 165)	16.79 ... 18.87 (620 ... 680)	1/2" / 600 / P7	16	80 (1.16)	5.0 (72.52)	1.0 (14.5)
	750 ... 850 (200 ... 220)	22.29 ... 25.26 (820 ... 920)	1/2" / 800 / R7	16	85 (1.23)	5.4 (78.32)	1.0 (14.5)

DN <sup>1)</sup>	Upper range value <sup>2)</sup> for		Meter tube / nominal flow rate H <sub>2</sub> O [l/h] / Order code <sup>3)</sup>	VIN <sup>4)</sup>	Pressure loss <sup>5)</sup> [mbar (psi)]	Minimum upstream pressure for gas measurement <sup>6)</sup>	
	Water [l/h (USgal/h)]	Air [m <sup>3</sup> /h (scfh)]				Without gas damping [bar abs (psia)]	With gas damping <sup>7)</sup> [bar abs (psia)]
DN 25 (1") G1 1/2"	280 ... 656 (74 ... 170)	8.32 ... 19.50 (310 ... 700)	1" / 400 / A1	13 ... 21	20 ... 76 (0.3 ... 1.1)	2.9 ... 3.1 (42.1 ... 45.0)	1.1 ... 1.4 (16.0 ... 20.3)
	393 ... 870 (104 ... 220)	11.70 ... 25.85 (430 ... 940)	1" / 600 / B1	7 ... 10	27 ... 76 (0.4 ... 1.1)	3.0 ... 3.4 (43.5 ... 49.3)	1.2 ... 1.4 (17.4 ... 20.3)
	660 ... 1600 (170 ... 450)	19.38 ... 50.80 (720 ... 1850)	1" / 1000 / C1	16 ... 22	20 ... 76 (0.3 ... 1.1)	3.3 ... 4.3 (48.0 ... 62.4)	1.1 ... 1.4 (16.0 ... 20.3)
	975 ... 2370 (260 ... 620)	28.98 ... 70.44 (1060 ... 2550)	1" / 1600 / D1	8 ... 10	27 ... 82 (0.4 ... 1.2)	3.3 ... 5.3 (48.0 ... 77.0)	1.2 ... 1.5 (17.4 ... 21.8)
	1650 ... 4020 (440 ... 1060)	49.04 ... 119.50 (1800 ... 4300)	1" / 2500 / E1	17 ... 6	20 ... 76 (0.3 ... 1.1)	4.2 ... 6.4 (61.0 ... 92.8)	1.1 ... 1.4 (16.0 ... 20.3)
	2585 ... 6170 (680 ... 1600)	76.83 ... 183.50 (2800 ... 6600)	1" / 4000 / F1	8 ... 10	27 ... 82 (0.4 ... 1.2)	5.2 ... 8.0 (75.4 ... 116)	1.2 ... 1.5 (17.4 ... 21.8)
DN 40 (1 1/2")	4220 ... 12130 (1120 ... 3200)	125.40 ... 360.50 (4600 ... 13000)	2" / 8000 / A2	21 ... 38	11 ... 62 (0.2 ... 0.9)	3.1 ... 4.5 (45.0 ... 65.3)	1.1 ... 1.4 (16.0 ... 20.3)
	DN 50 (2")	7940 ... 18460 (2100 ... 4800)	236.0 ... 584.6 (8600 ... 20000)	2" / 12000 / B2	13 ... 17	24 ... 74 (0.3 ... 1.1)	3.8 ... 6.2 (55.1 ... 90.0)
DN 80 (3")		11760 ... 24200 (3100 ... 6400)	349.50 ... 720.00 (13000 ... 27000)	2" / 18000 / C2	3 ... 4	28 ... 72 (0.4 ... 1.0)	4.4 ... 7.5 (63.8 ... 109)
	7000 ... 21010 (1850 ... 5500)	208.00 ... 624.40 (7600 ... 22000)	3" / 12000 / A3	22 ... 54	6 ... 48 (0.1 ... 0.7)	3.4 ... 5.4 (49.3 ... 78.3)	1.1 ... 1.3 (16.0 ... 18.9)
	18090 ... 35010 (4800 ... 9200)	537.70 ... 1040 (19500 ... 38000)	3" / 25000 / B3	18 ... 25	24 ... 65 (0.3 ... 1.0)	4.8 ... 7.4 (69.6 ... 107)	1.1 ... 1.4 (16.0 ... 20.3)
DN 100 (4")	29750 ... 53810 (7000 ... 14000)	795 ... 1600 (29000 ... 58000)	3" / 40000 / C3	4 ... 5	26 ... 68 (0.4 ... 1.0)	6.0 ... 9.2 (87.0 ... 133)	1.1 ... 1.4 (16.0 ... 20.3)
	25000 ... 50000 (5400 ... 13500)	—	4" / 40000 / A4	60 ... 81	28 ... 74 (0.4 ... 1.2)	—	—
	50000 ... 120000 (12500 ... 32000)	—	4" / 80000 / B4	24	42 ... 95 (0.6 ... 1.4)	—	—

1) Connection nominal size

2) The upper range value can be selected anywhere within these limits. The measuring span is 10:1.

Example: upper range value 12 m<sup>3</sup>/h (USgal/h) water, measuring span of device 1.2 to 12 m<sup>3</sup>/h (USgal/h) water.

3) Order code for meter tube / float combination (versions 18, 19), see chapter „Main ordering information FAM541“ on page 50.

4) Viscosity influence number (VIN), see chapter „Calculating the viscosity influence number (VIN)“ on page 5.

5) The listed pressure loss values are based on the listed upper range value.

6) The minimum required pressure (abs) to prevent compression oscillations (float bounce) in the meter tube. The specifications for the minimum required pressures with and without damping are based on average installation conditions. Some installations may have higher values (high free volume upstream / downstream of the device).

7) Cylinder / piston damping. For nominal diameters DN 15 ... DN 80 (1/2 ... 3").

8) These meter tube / float combinations always require gas piston damping for gas measurements.

# VA Master FAM540 Metal Cone Variable Area Flowmeter

## Dimensions

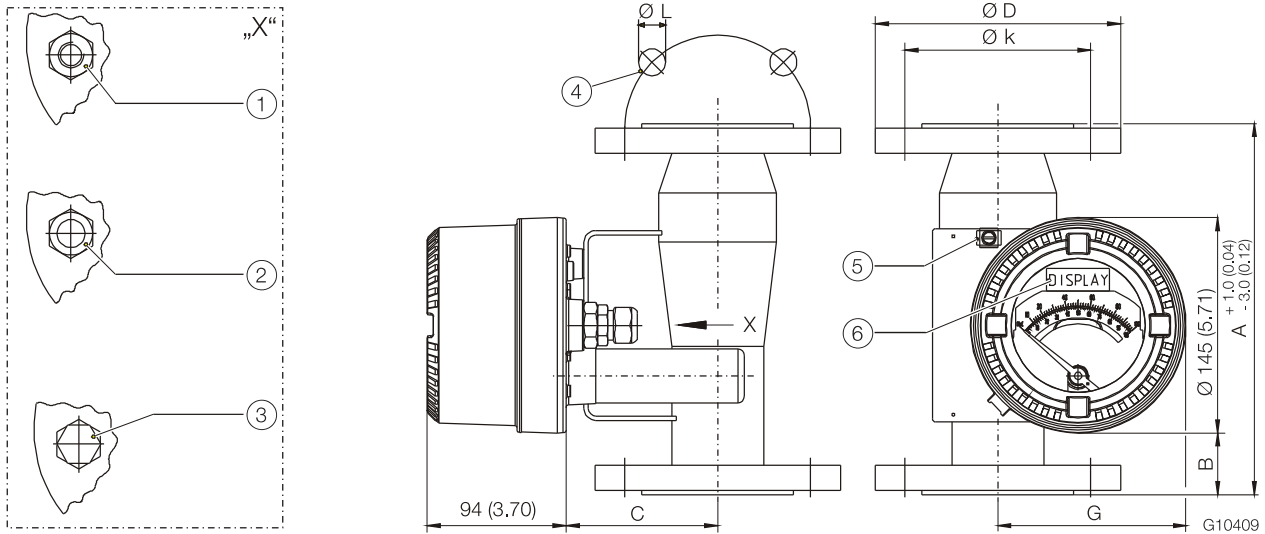

Fig. 14: Dimensions for flange devices in mm (inch), tolerances  $\pm 2$  mm

- ① Threaded bushing 1/2" NPT ② Cable gland M20x1.5 ③ Plug M25x1.5 (only for model FAM541-A) ④ N Number of holes  
⑤ Earthing terminal ⑥ LCD display, only for FAM541-F

Device size	Pressure rating	DN	Ø D [mm (inch)]	Ø k [mm (inch)]	Ø L [mm (inch)]	N	A [mm (inch)]	C [mm (inch)]	G [mm (inch)]	
1/2"	PN 40	DN 15	95.0 (3.74)	65.0 (2.56)	14.0 (0.55)	4	250.0 (9.84)	87.0 (3.43)	118.0 (4.65)	
	PN 63 / 100		105.0 (4.13)	75.0 (2.95)	14.0 (0.55)	4	258.0 (10.16)	87.0 (3.43)	118.0 (4.65)	
	CL 150	1/2"	89.0 (3.50)	60.3 (2.37)	15.9 (0.63)	4	250.0 (9.84)	87.0 (3.43)	118.0 (4.65)	
	CL 300		95.2 (3.75)	66.7 (2.63)	15.9 (0.63)	4	250.0 (9.84)	87.0 (3.43)	118.0 (4.65)	
	CL 600		95.2 (3.75)	66.5 (2.62)	15.7 (0.62)	4	260.0 (10.24)	87.0 (3.43)	118.0 (4.65)	
1"	PN 40	DN 25	115.0 (4.53)	85.0 (3.35)	14.0 (0.55)	4	250.0 (9.84)	87.0 (3.43)	118.0 (4.65)	
	PN 63 / 100		140.0 (5.51)	100.0 (3.94)	18.0 (0.71)	4	262.0 (10.31)	87.0 (3.43)	118.0 (4.65)	
	CL 150	1"	107.9 (4.25)	79.4 (3.13)	15.9 (0.63)	4	250.0 (9.84)	87.0 (3.43)	118.0 (4.65)	
	CL 300		123.8 (4.87)	88.9 (3.50)	19.0 (0.75)	4	250.0 (9.84)	87.0 (3.43)	118.0 (4.65)	
	CL 600		124.0 (4.88)	88.9 (3.50)	19.0 (0.75)	4	262.0 (10.31)	87.0 (3.43)	118.0 (4.65)	
2"	PN 40	DN 40	150 (5.91)	110 (4.33)	18.0 (0.71)	4	250.0 (9.84)	102.0 (4.02)	130.0 (5.12)	
	CL 150		1 1/2"	127 (5.0)	98.4 (3.87)	15.7 (0.62)	4	250.0 (9.84)	102.0 (4.02)	130.0 (5.12)
	CL 300		1 1/2"	155.3 (6.11)	114.3 (4.5)	22.2 (0.87)	4	250.0 (9.84)	102.0 (4.02)	130.0 (5.12)
	PN 40	DN 50	165.0 (6.50)	125.0 (4.92)	18.0 (0.71)	4	250.0 (9.84)	102.0 (4.02)	130.0 (5.12)	
	PN 63		180.0 (7.09)	135.0 (5.31)	22.0 (0.87)	4	262.0 (10.31)	102.0 (4.02)	130.0 (5.12)	
	PN 100		195.0 (7.68)	145.0 (5.71)	26.0 (1.02)	4	266.0 (10.47)	102.0 (4.02)	130.0 (5.12)	
	CL 150	2"	152.4 (6.00)	120.6 (4.75)	19.0 (0.75)	4	250.0 (9.84)	102.0 (4.02)	130.0 (5.12)	
	CL 300		165.1 (6.50)	127.0 (5.00)	19.0 (0.75)	8	250.0 (9.84)	102.0 (4.02)	130.0 (5.12)	
	CL 600		165.1 (6.50)	127.0 (5.00)	19.0 (0.75)	8	274.0 (10.79)	102.0 (4.02)	130.0 (5.12)	

Device size	Pressure rating	DN	Ø D [mm (inch)]	Ø k [mm (inch)]	Ø L [mm (inch)]	N	A [mm (inch)]	C [mm (inch)]	G [mm (inch)]
3"	PN 40	DN 80	200.0 (7.87)	160.0 (6.30)	18.0 (0.71)	8	250.0 (9.84)	132.0 (5.20)	144.0 (5.67)
	PN 63		215.0 (8.46)	170.0 (6.69)	22.0 (0.87)	8	258.0 (10.16)	132.0 (5.20)	144.0 (5.67)
	PN 100		230.0 (9.06)	180.0 (7.09)	26.0 (1.02)	8	272.0 (10.71)	132.0 (5.20)	144.0 (5.67)
	CL 150	3"	190.5 (7.50)	152.4 (6.00)	19.0 (0.75)	4	250.0 (9.84)	132.0 (5.20)	144.0 (5.67)
	CL 300		209.5 (8.25)	168.3 (6.63)	22.2 (0.87)	8	250.0 (9.84)	132.0 (5.20)	144.0 (5.67)
	CL 600		209.5 (8.25)	168.1 (6.62)	22.2 (0.87)	8	278.0 (10.94)	132.0 (5.20)	144.0 (5.67)
4"	PN 16	DN 100	220.0 (8.66)	180.0 (7.09)	18.0 (0.71)	8	250.0 (9.84)	147.0 (5.79)	158.0 (6.22)
	PN 40		235.0 (9.25)	190.0 (7.48)	22.0 (0.87)	8	250.0 (9.84)	147.0 (5.79)	158.0 (6.22)
	PN 63		250.0 (9.84)	200.0 (7.87)	26.0 (1.02)	8	262.0 (10.31)	147.0 (5.79)	158.0 (6.22)
	CL 150	4"	228.6 (9.00)	190.5 (7.50)	19.0 (0.75)	8	250.0 (9.84)	147.0 (5.79)	158.0 (6.22)
	CL 300		254.0 (10.00)	200.0 (7.87)	22.2 (0.87)	8	266.0 (10.47)	147.0 (5.79)	158.0 (6.22)

#### Overall length for devices with female thread connectors

Process connection	Overall length [mm (inch)]
Female thread 1"	296 (11.65)
Female thread 1 1/2"	304 (11.97)

#### Weight in kg (lb)

Indicator housing material	Device size (meter tube)				
	DN 15 (1/2")	DN 25 (1")	DN 50 (2")	DN 80 (3")	DN 100 (4")
Al Si 12	4.5 / (9.9)	5.8 / (12.8)	9.5 / (20.9)	15.7 / (34.6)	34.0 / (75)
Stainless steel 1.4408	7.0 / (15.4)	8.3 / (18.3)	12.0 / (26.4)	18.2 / (40.1)	36.5 / (80.4)



# VA Master FAM540

## Metal Cone Variable Area Flowmeter

### Model FAM544 - hygienic design



G10449

**Fig. 15: Model FAM544 in hygienic design**

This model has been specially constructed with threaded connections in accordance with DIN 11851 to meet the more stringent hygienic requirements of the food and beverage industry in respect of biological cleaning.

All parts of the flowmeter that come into contact with the measuring medium are welded and polished. There are no gaps or other empty areas. The device is suitable for cleaning or sterilization with steam, acids and alkali. The device is also CIP-cleanable.

#### Scale

Design optionally with percentage scale or product scale.

#### Gas damping

Not available.

#### SIL approval

- SIL2 declaration of conformity for devices with alarm function.
- Manufacturer's declaration (SIL1) in accordance with IEC 61508 / IEC61511 for devices with a current output of 4 ... 20 mA.

#### Measuring accuracy

1.6 % qg = 50 % in accordance with VDE / VDI 3513, sheet 2, optional 1 % of upper range value.

#### Measuring range limits and span limits

Measuring span: 10:1

For detailed information about measuring ranges, see chapter „Measuring range table“ on page 18.

#### Temperature limits °C (°F)

##### Medium temperature range

- -55 ... 400 °C (-67 ... 752 °F)

##### Ambient temperature range

- -40 ... 85 °C (-40 ... 185 °F)

#### NOTE

- When using in potentially explosive atmospheres, observe the temperature information in the ATEX / IECEx limit values starting from 34 and the FM / cCSAus limit values tables starting from „Safety specifications FM, cCSAus“ on page 43!
- Also observe the information in chapter „Temperature data“ on page 4!

#### Process connections

- Threaded spud in accordance with DIN 11851 (SC 25 ... SC 80)
- Threaded spud in accordance with SMS 1145 (DN 38 ... DN 102)

#### Connection dimensions

Nominal Diameter	Meter tube size	SMS 1145	DIN 11851
DN 25	1/2"	SC 25	—
DN 40	1"	SC 40	DN 38
DN 50	2"	SC 50	DN 51
DN 80	3"	SC 80	DN 76
DN 100	4"	—	DN 102
DN 125	4"	SC 125	—

#### Pressure ratings

Threaded spuds in accordance with DIN 11851:

- PN 25 for DN 50 ... DN 80 (2 ... 3")
- PN 40 for DN 25 ... DN 40 (1 ... 1 1/2")
- PN 16 for DN 125 (5")

Threaded spud in accordance with DIN 1145:

- PN 6 for (DN 38 ... DN 102)

See chapter „Material load“ on page 17.

#### Maximum permissible operating pressure

See chapter „Material load“ on page 17.

## Materials

### Materials for the indicator housing

Component	Material
Indicator housing	Standard: aluminum, powder-coated Option: stainless steel 1.4408
Powder coating	Epoxy paint 80 ... 100 µm Bottom color: RAL 7012 Cover color: RAL 9002
Housing gasket (O-ring)	Buna N®
Sight glass	Shatterproof glass

### Materials for wetted parts

Component	Material
Meter tube	Stainless steel 1.4404 (316 L)
Conical meter pipe	Stainless steel 1.4571 (316 Ti), only DN 15 (1/2)
Variable area	Stainless steel 1.4571 (316 Ti)

## Material load

Process connection	Nominal Diameter	PS <sub>max</sub>	TS <sub>min</sub>	TS <sub>max</sub>
DIN 11851	DN 15 ... 40 (1/2 ... 1 1/2")	40 bar (580 psi)	-40 °C (-40 °F)	140 °C (284 °F)
	DN 50 ... 100 (2 ... 4")	25 bar (362 psi)	-40 °C (-40 °F)	140 °C (284 °F)
	DN 125 (5")	16 bar (232 psi)	-40 °C (-40 °F)	140 °C (284 °F)
SMS 1145	DN 38 ... 102 (1 1/2 ... 4")	6 bar (87 psi)	-40 °C (-40 °F)	140 °C (284 °F)

# VA Master FAM540

## Metal Cone Variable Area Flowmeter

### Measuring range table

#### NOTE

The "FlowCalc" program, which is available as a free download from [www.abb.com/flow](http://www.abb.com/flow), can be used to calculate flow rates, pressure losses, and upstream pressure requirements.

The data listed applies to water at 20 °C (68 °F), 1 kg/dm<sup>3</sup> (62.43 lb/ft<sup>3</sup>), 1 mPas (1 cP) and to air at 0 °C (70 °F), 1013 mbar (14.7 psia).

DN <sup>1)</sup>	Upper range value <sup>2)</sup> for		Meter tube / nominal flow rate H <sub>2</sub> O [l/h] / Order code <sup>3)</sup>	VIN <sup>4)</sup>	Pressure loss <sup>5)</sup> [mbar (psi)]	Minimum upstream pressure for gas measurement <sup>6)</sup> [bar abs (psia)]
	Water [l/h (USgal/h)]	Air [m <sup>3</sup> /h (scfh)]				
DN 25 (1"*)	28 ... 32 (7.4 ... 8.5)	—	1/2" / 30 / A7	6	80 (1.16)	—
	37 ... 43 (10 ... 11.4)	—	1/2" / 40 / B7	6	80 (1.16)	—
	44 ... 55 (11.6 ... 14.5)	—	1/2" / 50 / C7	6	80 (1.16)	—
	56 ... 64 (14.5 ... 17)	—	1/2" / 60 / D7	6	80 (1.16)	—
	77 ... 83 (20.5 ... 21.5)	2.29 ... 2.47 (84 ... 90)	1/2" / 80 / E7	16	40 (0.58)	3.0 (43.51)
	96 ... 104 (25.5 ... 27)	2.85 ... 3.09 (104 ... 112)	1/2" / 100 / F7	16	45 (0.65)	3.2 (46.41)
	115 ... 125 (30 ... 33)	3.42 ... 3.72 (125 ... 135)	1/2" / 120 / G7	16	50 (0.73)	3.5 (50.76)
	144 ... 156 (38 ... 41)	4.28 ... 4.64 (155 ... 165)	1/2" / 150 / H7	16	60 (0.87)	3.8 (55.11)
	188 ... 212 (50 ... 56)	5.59 ... 6.30 (205 ... 230)	1/2" / 200 / J7	16	60 (0.87)	4.0 (58.02)
	235 ... 265 (62 ... 70)	6.98 ... 7.88 (255 ... 285)	1/2" / 250 / K7	16	65 (0.94)	4.2 (60.92)
	282 ... 318 (74 ... 84)	8.38 ... 9.45 (310 ... 340)	1/2" / 300 / L7	16	70 (1.02)	4.4 (63.82)
	376 ... 424 (100 ... 112)	11.17 ... 12.60 (410 ... 460)	1/2" / 400 / M7	16	75 (1.09)	4.6 (66.72)
	470 ... 530 (125 ... 140)	13.97 ... 15.75 (510 ... 570)	1/2" / 500 / N7	16	75 (1.09)	4.8 (69.62)
	565 ... 635 (150 ... 165)	16.79 ... 18.87 (620 ... 680)	1/2" / 600 / P7	16	80 (1.16)	5.0 (72.52)
	750 ... 850 (200 ... 220)	22.29 ... 25.26 (820 ... 920)	1/2" / 800 / R7	16	85 (1.23)	5.4 (78.32)

DN <sup>1)</sup>	Upper range value <sup>2)</sup> for		Meter tube / nominal flow rate H <sub>2</sub> O [l/h] / Order code <sup>3)</sup>	VIN <sup>4)</sup>	Pressure loss <sup>5)</sup> [mbar (psi)]	Minimum upstream pressure for gas measurement <sup>6)</sup> [bar abs (psia)]
	Water [l/h (USgal/h)]	Air [m <sup>3</sup> /h (scfh)]				
DN 40 (1 1/2")	280 ... 656 (74 ... 170)	8.32 ... 19.50 (310 ... 700)	1" / 400 / A1	13 ... 21	20 ... 76 (0.3 ... 1.1)	2.9 ... 3.1 (42.1 ... 45.0)
	393 ... 870 (104 ... 220)	11.70 ... 25.85 (430 ... 940)	1" / 600 / B1	7 ... 10	27 ... 76 (0.4 ... 1.1)	3.0 ... 3.4 (43.5 ... 49.3)
	660 ... 1600 (170 ... 450)	19.38 ... 50.80 (720 ... 1850)	1" / 1000 / C1	16 ... 22	20 ... 76 (0.3 ... 1.1)	3.3 ... 4.3 (48.0 ... 62.4)
	975 ... 2370 (260 ... 620)	28.98 ... 70.44 (1060 ... 2550)	1" / 1600 / D1	8 ... 10	27 ... 82 (0.4 ... 1.2)	3.3 ... 5.3 (48.0 ... 77.0)
	1650 ... 4020 (440 ... 1060)	49.04 ... 119.50 (1800 ... 4300)	1" / 2500 / E1	17 ... 6	20 ... 76 (0.3 ... 1.1)	4.2 ... 6.4 (61.0 ... 92.8)
	2585 ... 6170 (680 ... 1600)	76.83 ... 183.50 (2800 ... 6600)	1" / 4000 / F1	8 ... 10	27 ... 82 (0.4 ... 1.2)	5.2 ... 8.0 (75.4 ... 116)
DN 50 (2")	4220 ... 12130 (1120 ... 3200)	125.40 ... 360.50 (4600 ... 13000)	2" / 8000 / A2	21 ... 38	11 ... 62 (0.2 ... 0.9)	3.1 ... 4.5 (45.0 ... 65.3)
	7940 ... 18460 (2100 ... 4800)	236.0 ... 584.6 (8600 ... 20000)	2" / 12000 / B2	13 ... 17	24 ... 74 (0.3 ... 1.1)	3.8 ... 6.2 (55.1 ... 90.0)
	11760 ... 24200 (3100 ... 6400)	349.50 ... 720.00 (13000 ... 27000)	2" / 18000 / C2	3 ... 4	28 ... 72 (0.4 ... 1.0)	4.4 ... 7.5 (63.8 ... 109)
DN 50 (2"*)	3580 ... 7932 (944 ... 2080)	106.0 ... 236.0 (3830 ... 8520)	2" / 6000 Hygiene / H2	18 ... 28	18 ... 63 (0.3 ... 0.9)	3.1 ... 4.5 (45.0 ... 65.3)
	7670 ... 16700 (2025 ... 4400)	228.3 ... 496.0 (8520 ... 17900)	2" / 12000 Hygiene / J2	8 ... 9	33 ... 77 (0.5 ... 1.1)	3.8 ... 6.2 (55.1 ... 90.0)
DN 80 (3")	7000 ... 21010 (1850 ... 5500)	208.00 ... 620 (7600 ... 22000)	3" / 12000 / A3	22 ... 54	6 ... 48 (0.1 ... 0.7)	3.4 ... 5.4 (49.3 ... 78.3)
	18090 ... 35010 (4800 ... 9200)	537.70 ... 1040 (19500 ... 38000)	3" / 25000 / B3	18 ... 25	24 ... 65 (0.3 ... 1.0)	4.8 ... 7.4 (69.6 ... 107)
	29750 ... 53810 (7000 ... 14000)	795 ... 1550 (29000 ... 58000)	3" / 40000 / C3	4 ... 5	26 ... 68 (0.4 ... 1.0)	6.0 ... 9.2 (87.0 ... 133)
DN 80 (3"*)	9864 ... 21420 (2550 ... 5650)	293.0 ... 637.0 (10600 ... 23000)	3" / 16000 Hygiene / H3	25 ... 43	13 ... 49 (0.2 ... 0.7)	3.4 ... 5.4 (49.3 ... 78.3)
	22800 ... 41640 (6015 ... 10950)	677.0 ... 1237.0 (24500 ... 44600)	3" / 30000 Hygiene / H3	15 ... 18	30 ... 66 (0.4 ... 1.0)	4.8 ... 7.4 (69.6 ... 107)
DN 100 / DN 125 (4"*) / (5"*)	25000 ... 50000 (5400 ... 13500)	—	4" / 40000 / A4	60 ... 81	28 ... 74 (0.4 ... 1.2)	—
	50000 ... 120000 (12500 ... 32000)	—	4" / 80000 / B4	24	42 ... 95 (0.6 ... 1.4)	—

1) Connection nominal size

2) The upper range value can be selected anywhere within these limits. The measuring span is 10:1.

Example: upper range value 12 m<sup>3</sup>/h (USgal/h) water, measuring span of device 1.2 to 12 m<sup>3</sup>/h (USgal/h) water.

3) Order code for meter tube /float combination (versions 18, 19), see chapter „Main ordering information FAM544“ on page 54.

4) Viscosity influence number (VIN), see chapter „Calculating the viscosity influence number (VIN)“ on page 5.

5) The listed pressure loss values are based on the listed flow rate end value.

6) The minimum required pressure (abs) to prevent compression oscillations (float bounce) in the meter tube. The specifications for the minimum required pressures are based on average installation conditions. Some installations may have higher values (high free volume upstream / downstream of the device).

7) Only for threaded spuds in accordance with DIN 11851

8) Only for threaded spuds in accordance with SMS 1145

# VA Master FAM540 Metal Cone Variable Area Flowmeter

## Dimensions

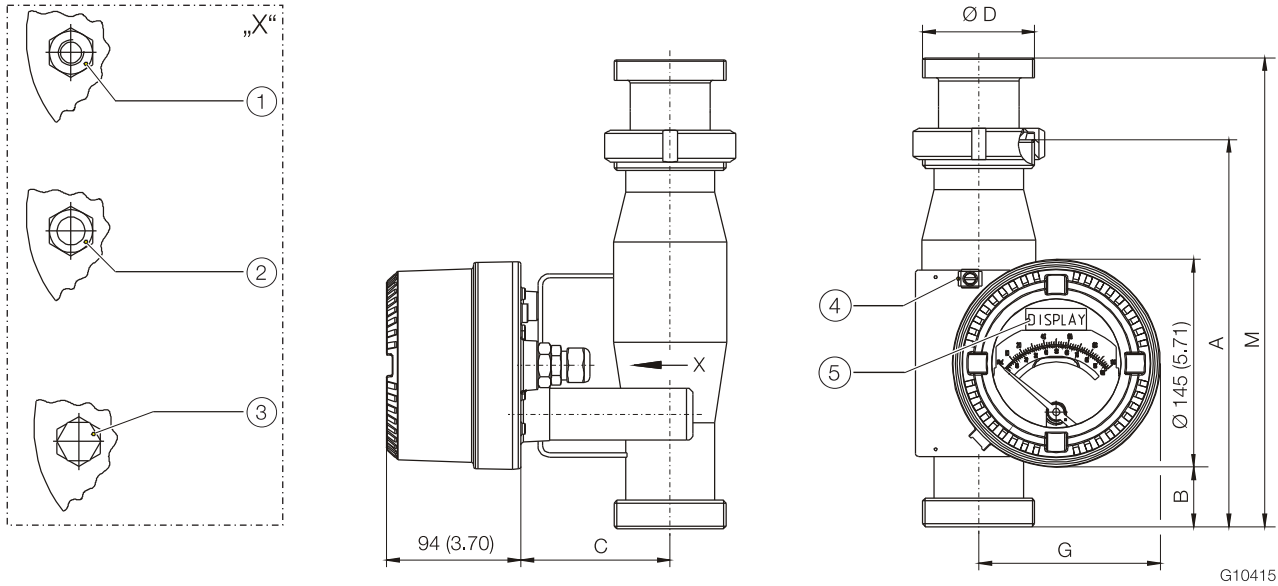

Fig. 16: Dimensions in mm (inch), tolerances  $\pm 2$  mm

- ① Threaded bushing 1/2" NPT ② Cable gland M20x1.5 ③ Plug M25x1.5 (only for model FAM541-A) ④ Earthing terminal  
⑤ LCD display only for FAM541-F

## Dimensions for devices with threaded spuds in accordance with DIN 11851

Device size	DN [mm (inch)]	Pressure rating	$\varnothing$ D	A <sup>1)</sup> [mm (inch)]	B [mm (inch)]	C [mm (inch)]	G [mm (inch)]	M <sup>1)</sup> [mm (inch)]
1/2"	25 (1")	PN 40	Rd 52 x 1/6"	270.0 (10.63)	51.5 (2.03)	87.0 (3.43)	118.0 (4.65)	—
1"	40 (1 1/2")	PN 40	Rd 65 x 1/6"	270.0 (10.63)	51.5 (2.03)	87.0 (3.43)	118.0 (4.65)	—
2"	50 (2")	PN 25	Rd 78 x 1/6"	270.0 (10.63)	51.5 (2.03)	102.0 (4.02)	130.0 (5.12)	315.0 (12.40)
3"	80 (3")	PN 25	Rd 110 x 1/6"	272.0 (10.71)	52.5 (2.07)	132.0 (5.20)	144.0 (5.67)	326.0 (12.83)
4"	125 (5")	PN 16	Rd 160 x 1/4"	320.0 (12.6)	76.5 (3.01)	147.0 (5.79)	158.0 (6.22)	—

<sup>1</sup> Dimension A: design with threaded spud DIN 11851

Dimension M: hygienic design with threaded spud in accordance with DIN 11851 (available upon request)

Dimensions for devices with threaded spuds in accordance with SMS 1145

Device size	DN [mm]	Pressure rating	Ø D	A [mm (inch)]	B [mm (inch)]	C [mm (inch)]	G [mm (inch)]
1"	38	PN 6	Rd 60 x 1/6"	300.0 (11.81)	66.5 (2.62)	87.0 (3.43)	118.0 (4.65)
2"	51		Rd 70 x 1/6"			102.0 (4.02)	130.0 (5.12)
3"	76		Rd 98 x 1/6"			132.0 (5.20)	144.0 (5.67)
4"	102		Rd 132 x 1/6"			147.0 (5.79)	158.0 (6.22)

Weight in kg (lb)

Indicator housing material	Device size (meter tube)					
	DN 15 (1/2")	DN 25 (1")	DN 50 (2")	DN 80 (3")	DN 100 (4")	DN 125 (5")
Al Si 12	4.5 (9.9)	5.8 (12.8)	9.0 (19.8)	15.7 (34.6)	24.0 (53.0)	34.0 (75.0)
Stainless steel 1.4408	7.0 (15.4)	8.3 (18.3)	11.5 (25.3)	18.2 (40.1)	26.5 (58.0)	36.5 (80.4)

# VA Master FAM540

## Metal Cone Variable Area Flowmeter

### Model FAM545 - with PTFE liner



Fig. 17: Model FAM545 with PTFE liner

#### NOTE

If the device is used in potentially explosive atmospheres, a minimum measuring medium conductivity of  $> 10^{-8}$  S/m must be guaranteed.

See also chapters „Use in potentially explosive atmospheres according to ATEX and IECEx“ on page 32 and „Dimensions“ on page 25.

#### Scale

Design optionally with percentage scale or product scale.

#### Gas damping

Not available.

#### SIL approval

Not available.

#### Measuring accuracy

2.5 % qg = 50 % in accordance with VDE / VDI 3513, sheet 2.

#### Measuring range limits and span limits

Measuring span: 10:1

For detailed information about measuring ranges, see chapter „Measuring range table“ on page 24.

#### Temperature limits °C (°F)

##### Medium temperature range

- -20 ... 125 °C (-4 ... 257 °F)

##### Ambient temperature range

- -40 ... 85 °C (-40 ... 185 °F)

#### NOTE

For use in potentially explosive atmospheres, observe the temperature information in the ATEX / IECEx limit values starting from 34 and the FM / cCSAus limit values tables starting from „Safety specifications FM, cCSAus“ on page 43!

- Also observe the information in chapter „Temperature data“ on page 4!

#### Process connections

- Flange in accordance with DIN 2501 (DN 25 ... DN 80)
- Flange in accordance with ASME B16.5

#### Pressure ratings

- Standard pressure rating PN 40
- Flange in accordance with DIN 2501 (DN 40 ... DN 63)
- Flange in accordance with ASME CL 150, CL 300

See chapter „Material load“ on page 23.

#### Maximum permissible operating pressure

50 bar (CL 300), (higher pressures available upon request).

## Materials

### Materials for the indicator housing

Component	Material
Indicator housing	Standard: aluminum, powder-coated Option: stainless steel 1.4408
Powder coating	Epoxy paint 80 ... 100 µm Bottom color: RAL 7012 Cover color: RAL 9002
Housing gasket (O-ring)	Buna N®
Sight glass	Shatterproof glass

### Materials for wetted parts

Component	Material
Meter tube	Stainless steel 1.4571 (316 Ti)
Conical meter pipe	PTFE
Flange	Stainless steel 1.4571 (316 Ti)
Variable area	PTFE

## Material load

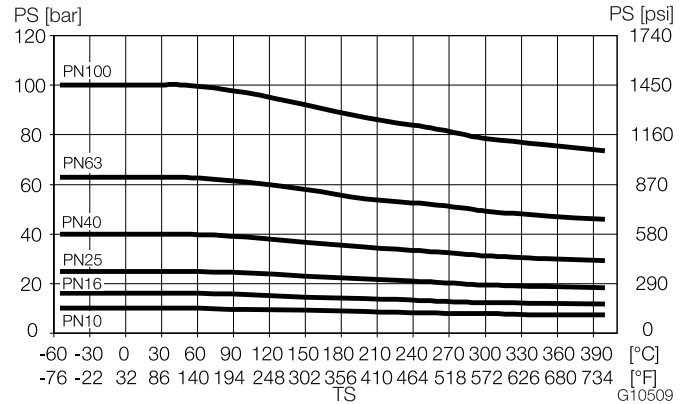

Fig. 18: DIN flange made from stainless steel

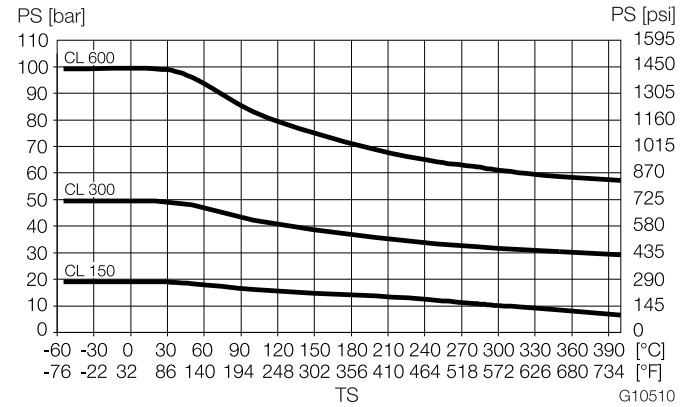

Fig. 19: ASME flange made from stainless steel



# VA Master FAM540

## Metal Cone Variable Area Flowmeter

### Measuring range table

#### NOTE

The "FlowCalc" program, which is available as a free download from [www.abb.com/flow](http://www.abb.com/flow), can be used to calculate flow rates, pressure losses, and upstream pressure requirements.

The data listed applies to water at 20 °C (68 °F), 1 kg/dm<sup>3</sup> (62.43 lb/ft<sup>3</sup>), 1 mPas (1 cP) and to air at 0 °C (70 °F), 1013 mbar (14.7 psia).

DN <sup>1)</sup>	Upper range value <sup>2)</sup> for		Meter tube / nominal flow rate H <sub>2</sub> O [l/h] / Order code <sup>3)</sup>	VIN <sup>4)</sup>	Pressure loss <sup>5)</sup> [mbar (psi)]
	Water [l/h (USgal/h)]	Air [m <sup>3</sup> /h (scfh)]			
DN 25 (1")	270 ... 370 (72 ... 96)	8.02 ... 11.0 (340 ... 470)	1" / 300 / K1	18	30 ... 55 (0.4 ... 0.8)
	370 ... 530 (98 ... 140)	11.0 ... 15.75 (440 ... 620)	1" / 500 / L1	18	35 ... 60 (0.5 ... 0.9)
	530 ... 750 (140 ... 195)	15.75 ... 22.29 (680 ... 940)	1/2" / 600 / M1	18	40 ... 65 (0.6 ... 0.9)
	750 ... 1050 (200 ... 275)	22.29 ... 31.21 (920 ... 1250)	1" / 900 / N1	18	45 ... 70 (0.7 ... 1.0)
	1050 ... 1500 (275 ... 390)	31.21 ... 44.58 (1300 ... 1800)	1" / 1300 / P1	18	55 ... 80 (0.8 ... 1.2)
	1500 ... 2100 (400 ... 550)	44.58 ... 62.41 (1850 ... 2600)	1" / 1800 / R1	18	65 ... 90 (0.9 ... 1.3)
	2100 ... 3000 (550 ... 780)	62.41 ... 89.16 (2600 ... 3600)	1" / 2500 / S1	18	75 ... 100 (1.1 ... 1.5)
DN 50 (2")	2850 ... 3350 (760 ... 920)	84.70 ... 105.50 (3300 ... 4000)	2" / 3200 / K2	26	40 ... 80 (0.6 ... 1.2)
	3350 ... 4450 (940 ... 1160)	105.50 ... 132.20 (4100 ... 5000)	2" / 4000 / L2	26	45 ... 85 (0.7 ... 1.2)
	4450 ... 5450 (1180 ... 1400)	132.20 ... 162.00 (5100 ... 6200)	2" / 5000 / M2	26	50 ... 90 (0.7 ... 1.3)
	5450 ... 6750 (1450 ... 1750)	162.00 ... 200.60 (6200 ... 7600)	2" / 6000 / N2	26	60 ... 100 (0.9 ... 1.5)
	6750 ... 8250 ( 1800 2150)	200.60 ... 245.20 (7800 ... 9400)	2" / 7500 / P2	26	70 ... 110 (1.0 ... 1.6)
	8250 ... 10000 (2200 ... 2600)	245.20 ... 297.20 (9400 ... 11400)	2" / 9100 / R2	26	90 ... 130 (1.3 ... 1.9)
DN 80 (3")	10000 ... 14000 ( 2650 3600)	294.20 ... 416.10 (12000 ... 16500)	3" / 12000 / K3	36	40 ... 70 (0.6 ... 1.0)
	14000 ... 19000 (3700 ... 5000)	416.20 ... 564.70 (17000 ... 23000)	3" / 16500 / L3	36	60 ... 90 (0.3 ... 1.3)
	19000 ... 27000 (5000 ... 7000)	564.70 ... 802.40 (23000 ... 32000)	3" / 23000 / M3	20	80 ... 110 (1.2 ... 1.6)

1) Connection nominal size

2) The upper range value can be selected anywhere within these limits. The measuring span is 10:1.

Example: upper range value 12 m<sup>3</sup>/h (USgal/h) water, measuring span of device 1.2 to 12 m<sup>3</sup>/h (USgal/h) water.

3) Order code for meter tube /float combination (versions 18, 19), see chapter „Main ordering information FAM545“ on page 57.

4) Viscosity influence number (VIN), see chapter „Calculating the viscosity influence number (VIN)“ on page 5.

5) The listed pressure loss values are based on the listed flow rate end value.

## Dimensions

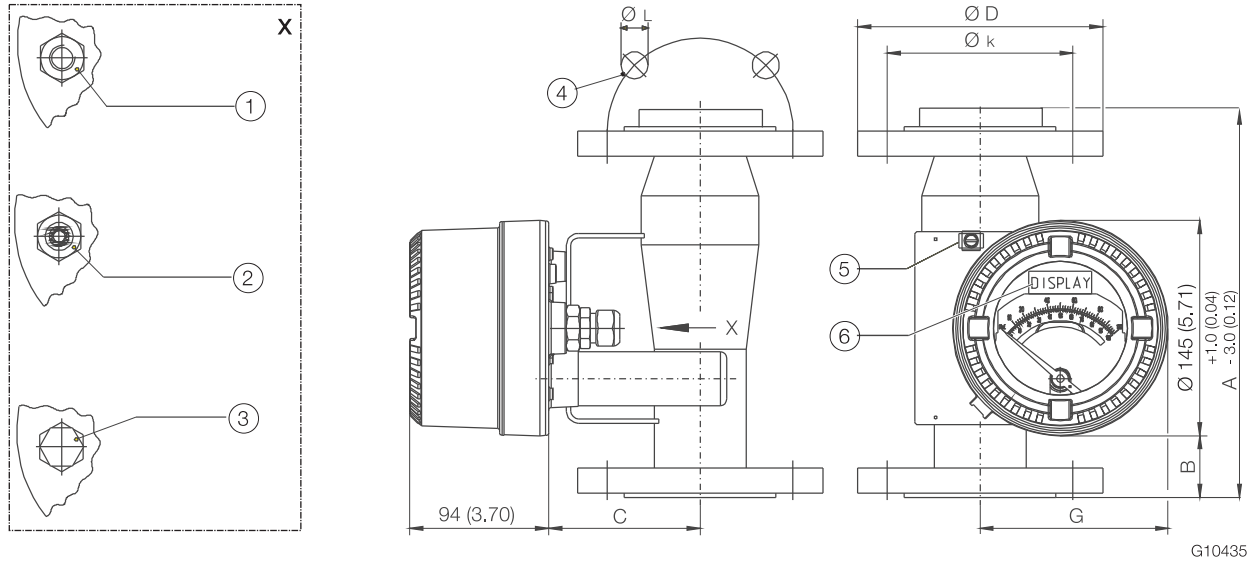

Fig. 20: Dimensions in mm (inch), tolerances  $\pm 2$  mm

- ① Threaded bushing 1/2" NPT ② Cable gland M20x1.5 ③ Plug M25x1.5 (only for model FAM545-A) ④ N Number of holes  
 ⑤ Earthing terminal ⑥ LCD display only for FAM545-F

Device size	Pressure rating	DN	$\varnothing D$ [mm (inch)]	$\varnothing k$ [mm (inch)]	$\varnothing L$ [mm (inch)]	N	A [mm (inch)]	C [mm (inch)]	G [mm (inch)]
1"	PN 40	DN 25	115.0 (4.53)	85.0 (3.35)	14.0 (0.55)	4	260.0 (10.24)	87.0 (3.43)	118.0 (4.65)
	CL 150	1"	107.9 (4.25)	79.4 (3.13)	15.9 (0.63)	4	260.0 (10.24)	87.0 (3.43)	118.0 (4.65)
	CL 300	1"	123.8 (4.87)	88.9 (3.50)	19.0 (0.75)	4	260.0 (10.24)	87.0 (3.43)	118.0 (4.65)
2"	PN 40	DN 50	165.0 (6.50)	125.0 (4.92)	18.0 (0.71)	4	375.0 (14.76)	102.0 (4.02)	130.0 (5.12)
	CL 150	2"	152.4 (6.00)	120.6 (4.75)	19.0 (0.75)	4	375.0 (14.76)	102.0 (4.02)	130.0 (5.12)
	CL 300	2"	165.1 (6.50)	127.0 (5.00)	19.0 (0.75)	8	375.0 (14.76)	102.0 (4.02)	130.0 (5.12)
3"	PN 40	DN 80	200 (7.87)	160.0 (6.30)	18.0 (0.71)	8	375.0 (14.76)	132.0 (5.20)	144.0 (5.67)
	CL 150	3"	190.5 (7.50)	152.4 (6.00)	19.0 (0.75)	4	375.0 (14.76)	132.0 (5.20)	144.0 (5.67)
	CL 300	3"	209.5 (8.25)	168.3 (6.63)	22.2 (0.87)	8	375.0 (14.76)	132.0 (5.20)	144.0 (5.67)

## Weight in kg (lb)

Indicator housing material	Device size (meter tube)		
	DN 25 (1")	DN 50 (2")	DN 80 (3")
Al Si 12	5.8 (12.8)	10.7 (23.6)	16.7 (36.8)
Stainless steel 1.4408	8.3 (18.3)	13.2 (29.1)	19.2 (42.3)

# VA Master FAM540

## Metal Cone Variable Area Flowmeter

### Model FAM546 - with heating jacket



G10451

Fig. 21: Model FAM541

#### Scale

Design optionally with percentage scale or product scale.

#### Gas damping

Option, for preventing compression oscillations in case of gas measurements with low operating pressure.

#### SIL approval

- SIL2 declaration of conformity for devices with alarm function.
- Manufacturer's declaration (SIL1) in accordance with IEC 61508 / IEC61511 for devices with a current output of 4 ... 20 mA.

#### Measuring accuracy

1.6 % qg = 50 % in accordance with VDE / VDI 3513, sheet 2, optional 1 % of upper range value.

#### Measuring range limits and span limits

Measuring span: 10:1

For detailed information about measuring ranges, see chapter „Measuring range table“ on page 28.

#### Temperature limits °C (°F)

##### Medium temperature range

- -55 ... 400 °C (-67 ... 752 °F)

##### Ambient temperature range

- -40 ... 85 °C (-40 ... 185 °F)

#### NOTE

- When using in potentially explosive atmospheres, observe the temperature information in the ATEX / IECEx limit values starting from 34 and the FM / cCSAus limit values tables starting from „Safety specifications FM, cCSAus“ on page 43!
- Also observe the information in chapter „Temperature data“ on page 4!

#### Process connections

- Flange in accordance with DIN 2501 (DN 50 (2") ... DN 100 (4"))
- Flange in accordance with EN 1092-1 (DN 25 (1"))
- Flange in accordance with ASME B16.5

#### Heating jacket connection

Female thread G 1/4, at the back of the meter tube.

#### Pressure ratings

- Standard pressure rating: PN 40 (PN 16 for DN 100 (4"))
- Flange in accordance with DIN / EN: PN 16, PN 40, PN 63, PN 100
- Flange in accordance with ASME: CL 150, CL 300, CL 600
- Heating jacket: PN 16

See chapter „Material load“ on page 27.

#### Maximum permissible operating pressure

- Meter tube: 100 bar (CL 600).
- Heating jacket: 16 Bar (232 psi)

Higher pressures on request.

## Materials

### Materials for the indicator housing

Component	Material
Indicator housing	Standard: aluminum, powder-coated Option: stainless steel 1.4408
Powder coating	Epoxy paint 80 ... 100 µm Bottom color: RAL 7012 Cover color: RAL 9002
Housing gasket (O-ring)	Buna N®
Sight glass	Shatterproof glass

### Materials for wetted parts

Component	Material
Meter tube	Stainless steel 1.4571 (316 Ti)
Conical meter pipe	Stainless steel 1.4571 (316 Ti), only DN 15 (1/2")
Flange	Stainless steel 1.4571 (316 Ti)
Variable area	– Stainless steel 1.4571 (316 Ti), standard – Stainless steel 1.4571 (316 Ti) / float head: Hastelloy™ C 2.4610, optional
Gas damping (option)	Stainless steel 1.4571 (316 Ti)

## Material load

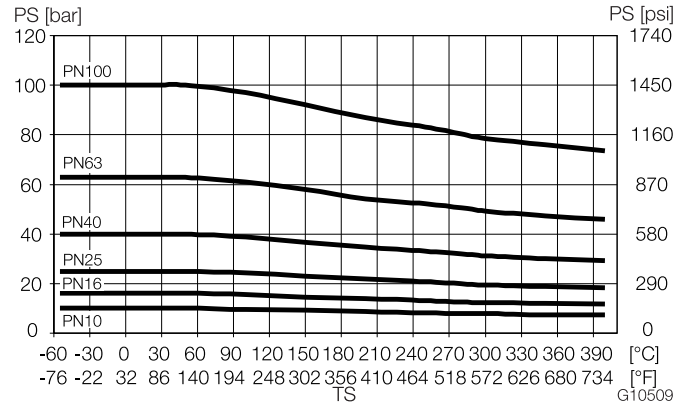

Fig. 22: DIN flange made from stainless steel

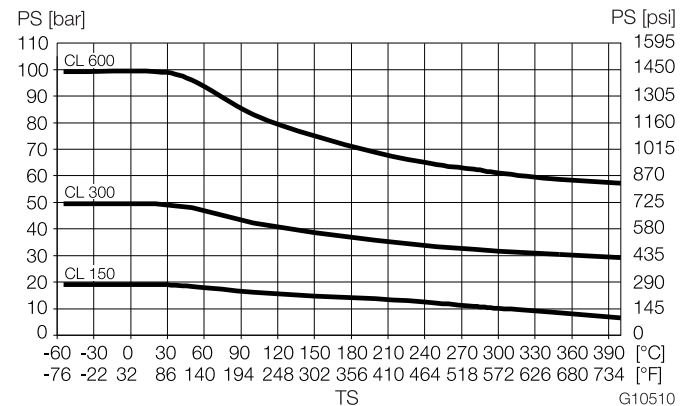

Fig. 23: ASME flange made from stainless steel

# VA Master FAM540

## Metal Cone Variable Area Flowmeter

### Measuring range table

#### NOTE

The "FlowCalc" program, which is available as a free download from [www.abb.com/flow](http://www.abb.com/flow), can be used to calculate flow rates, pressure losses, and upstream pressure requirements.

The specified data applies to water at 20 °C (68 °F) 1 kg/dm<sup>3</sup> (62.43 lb/ft<sup>3</sup>), 1 mPas (1 cP) and to air at 10 °C (70 °F), 1013 mbar (14.7 psia).

DN <sup>1)</sup>	Upper range value <sup>2)</sup> for		Meter tube / nominal flow rate H <sub>2</sub> O [l/h] / Order code <sup>3)</sup>	VIN <sup>4)</sup>	Pressure loss <sup>5)</sup> [mbar (psi)]	Minimum upstream pressure for gas measurement <sup>6)</sup>	
	Water [l/h (USgal/h)]	Air [m <sup>3</sup> /h (scfh)]				Without gas damping [bar abs (psia)]	With gas damping <sup>7)</sup> [bar abs (psia)]
DN 25 (1")	28 ... 32 (7.4 ... 8.5)	0.83 ... 0.95 (37 ... 45)	1/2" / 30 / A7 <sup>8)</sup>	6	80 (1.16)	4.0 (58.02)	1.0 (14.5)
	37 ... 43 (10 ... 11.4)	1.10 ... 1.28 (52 ... 59)	1/2" / 40 / B7 <sup>8)</sup>	6	80 (1.16)	4.0 (58.02)	1.0 (14.5)
	44 ... 55 (11.6 ... 14.5)	1.30 ... 1.63 (54 ... 66)	1/2" / 50 / C7 <sup>8)</sup>	6	80 (1.16)	4.0 (58.02)	1.0 (14.5)
	56 ... 64 (14.5 ... 17)	1.66 ... 1.90 (68 ... 80)	1/2" / 60 / D7 <sup>8)</sup>	6	80 (1.16)	4.0 (58.02)	1.0 (14.5)
	77 ... 83 (20.5 ... 21.5)	2.29 ... 2.47 (84 ... 90)	1/2" / 80 / E7	16	40 (0.58)	3.0 (43.51)	1.0 (14.5)
	96 ... 104 (25.5 ... 27)	2.85 ... 3.09 (104 ... 112)	1/2" / 100 / F7	16	45 (0.65)	3.2 (46.41)	1.0 (14.5)
	115 ... 125 (30 ... 33)	3.42 ... 3.72 (125 ... 135)	1/2" / 120 / G7	16	50 (0.73)	3.5 (50.76)	1.0 (14.5)
	144 ... 156 (38 ... 41)	4.28 ... 4.64 (155 ... 165)	1/2" / 150 / H7	16	60 (0.87)	3.8 (55.11)	1.0 (14.5)
	188 ... 212 (50 ... 56)	5.59 ... 6.30 (205 ... 230)	1/2" / 200 / J7	16	60 (0.87)	4.0 (58.02)	1.0 (14.5)
	235 ... 265 (62 ... 70)	6.98 ... 7.88 (255 ... 285)	1/2" / 250 / K7	16	65 (0.94)	4.2 (60.92)	1.0 (14.5)
	282 ... 318 (74 ... 84)	8.38 ... 9.45 (310 ... 340)	1/2" / 300 / L7	16	70 (1.02)	4.4 (63.82)	1.0 (14.5)
	376 ... 424 (100 ... 112)	11.17 ... 12.60 (410 ... 460)	1/2" / 400 / M7	16	75 (1.09)	4.6 (66.72)	1.0 (14.5)
	470 ... 530 (125 ... 140)	13.97 ... 15.75 (510 ... 570)	1/2" / 500 / N7	16	75 (1.09)	4.8 (69.62)	1.0 (14.5)
	565 ... 635 (150 ... 165)	16.79 ... 18.87 (620 ... 680)	1/2" / 600 / P7	16	80 (1.16)	5.0 (72.52)	1.0 (14.5)
750 ... 850 (200 ... 220)	22.29 ... 25.26 (820 ... 920)	1/2" / 800 / R7	16	85 (1.23)	5.4 (78.32)	1.0 (14.5)	

DN <sup>1)</sup>	Upper range value <sup>2)</sup> for		Meter tube / nominal flow rate H <sub>2</sub> O [l/h] / Order code <sup>3)</sup>	VIN <sup>4)</sup>	Pressure loss <sup>5)</sup> [mbar (psi)]	Minimum upstream pressure for gas metering <sup>6)</sup>	
	Water [l/h (USgal/h)]	Air [m <sup>3</sup> /h (scfh)]				Without gas damping [bar abs (psia)]	With gas damping <sup>7)</sup> [bar abs (psia)]
DN 50 (2")	280 ... 656 (74 ... 170)	8.32 ... 19.50 (310 ... 700)	1" / 400 / A1	13 ... 21	20 ... 76 (0.3 ... 1.1)	2.9 ... 3.1 (42.1 ... 45.0)	1.1 ... 1.4 (16.0 ... 20.3)
	393 ... 870 (104 ... 220)	11.70 ... 25.85 (430 ... 940)	1" / 600 / B1	7 ... 10	27 ... 76 (0.4 ... 1.1)	3.0 ... 3.4 (43.5 ... 49.3)	1.2 ... 1.4 (17.4 ... 20.3)
	660 ... 1600 (170 ... 450)	19.38 ... 50.80 (720 ... 1850)	1" / 1000 / C1	16 ... 22	20 ... 76 (0.3 ... 1.1)	3.3 ... 4.3 (48.0 ... 62.4)	1.1 ... 1.4 (16.0 ... 20.3)
	975 ... 2370 (260 ... 620)	28.98 ... 70.44 (1060 ... 2550)	1" / 1600 / D1	8 ... 10	27 ... 82 (0.4 ... 1.2)	3.3 ... 5.3 (48.0 ... 77.0)	1.2 ... 1.5 (17.4 ... 21.8)
	150 ... 4020 (440 ... 1060)	49.04 ... 119.50 (1800 ... 4300)	1" / 2500 / E1	17 ... 6	20 ... 76 (0.3 ... 1.1)	4.2 ... 6.4 (61.0 ... 92.8)	1.1 ... 1.4 (16.0 ... 20.3)
	285 ... 6170 (680 ... 1600)	76.83 ... 183.50 (2800 ... 6600)	1" / 4000 / F1	8 ... 10	27 ... 82 (0.4 ... 1.2)	5.2 ... 8.0 (75.4 ... 116)	1.2 ... 1.5 (17.4 ... 21.8)
DN 80 (3")	420 ... 12130 (1120 ... 3200)	125.40 ... 360.50 (4600 ... 13000)	2" / 8000 / A2	21 ... 38	11 ... 62 (0.2 ... 0.9)	3.1 ... 4.5 (45.0 ... 65.3)	1.1 ... 1.4 (16.0 ... 20.3)
	7940 ... 1860 (2100 ... 4800)	236.0 ... 584.6 (8600 ... 20000)	2" / 12000 / B2	13 ... 17	24 ... 74 (0.3 ... 1.1)	3.8 ... 6.2 (55.1 ... 90.0)	1.1 ... 1.4 (16.0 ... 20.3)
	11760 ... 24200 (3100 ... 6400)	349.50 ... 720.00 (13000 ... 27000)	2" / 18000 / C2	3 ... 4	28 ... 72 (0.4 ... 1.0)	4.4 ... 7.5 (63.8 ... 109)	1.1 ... 1.4 (16.0 ... 20.3)
DN 100 (4")	7000 ... 21010 (1850 ... 5500)	208.00 ... 624.40 (7600 ... 22000)	3" / 12000 / A3	22 ... 54	6 ... 48 (0.1 ... 0.7)	3.4 ... 5.4 (49.3 ... 78.3)	1.1 ... 1.3 (16.0 ... 18.9)
	18090 ... 35010 (4800 ... 9200)	537.70 ... 1040 (19500 ... 38000)	3" / 25000 / B3	18 ... 25	24 ... 65 (0.3 ... 1.0)	4.8 ... 7.4 (69.6 ... 107)	1.1 ... 1.4 (16.0 ... 20.3)
	29750 ... 53810 (7000 ... 14000)	795 ... 1600 (29000 ... 58000)	3" / 40000 / C3	4 ... 5	26 ... 68 (0.4 ... 1.0)	6.0 ... 9.2 (87.0 ... 133)	1.1 ... 1.4 (16.0 ... 20.3)

1) Connection nominal size

2) The upper range value can be selected anywhere within these limits. The measuring span is 10:1.

Example: upper range value 12 m<sup>3</sup>/h (USgal/h) water, measuring span of device 1.2 to 12 m<sup>3</sup>/h (USgal/h) water.

3) Order code for meter tube /float combination (versions 18, 19), see chapter „Main ordering information FAM546“ on page 60.

4) Viscosity influence number (VIN), see chapter „Calculating the viscosity influence number (VIN)“ on page 5.

5) The listed pressure loss values are based on the listed flow rate end value.

6) The minimum required pressure (abs) to prevent compression oscillations (float bounce) in the meter tube. The specifications for the minimum required pressures with and without damping are based on average installation conditions. Some installations may have higher values (high free volume upstream / downstream of the device).

7) Cylinder / piston damping. For nominal diameters DN 15 ... DN 80 (1/2 ... 3").

8) These meter tube/float combinations always require gas piston damping for gas measurements.

# VA Master FAM540 Metal Cone Variable Area Flowmeter

## Dimensions

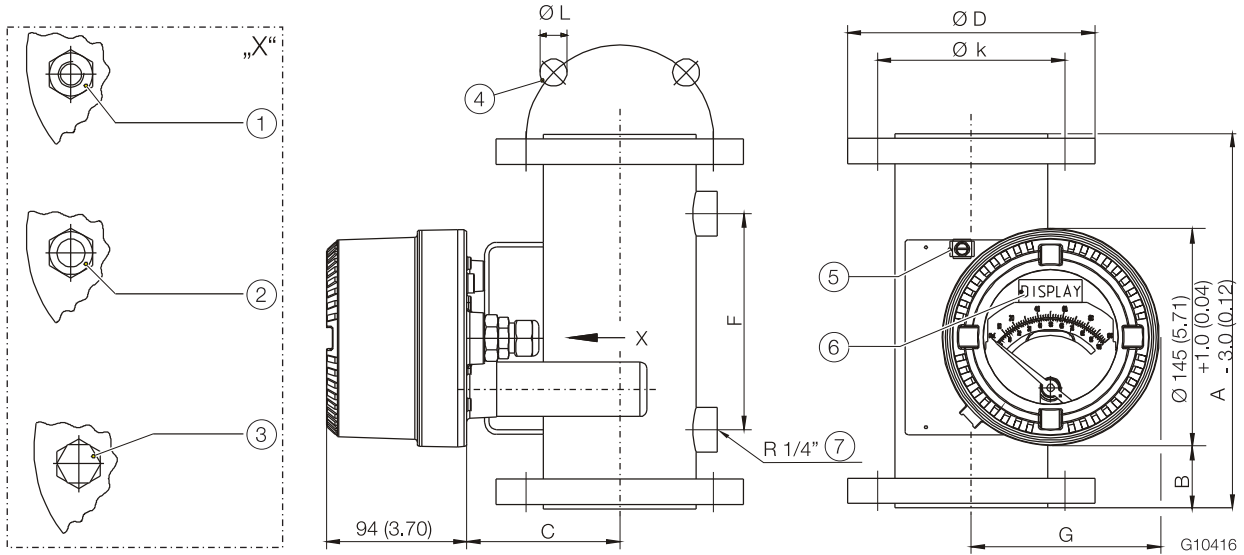

Fig. 24: Dimensions in mm (inch), tolerances  $\pm 2$  mm

- ① Threaded bushing 1/2" NPT ② Cable gland M20x1.5 ③ Plug M25x1.5 (only for model FAM546-A) ④ N Number of holes  
⑤ Earthing terminal ⑥ LCD display only for FAM546-F ⑦ Heating jacket connectors 1/2" NPT on request

Device size	Pressure rating	Ø D [mm (inch)]	Ø k [mm (inch)]	Ø L [mm (inch)]	N	A [mm (inch)]	B [mm (inch)]	C [mm (inch)]	F [mm (inch)]	G [mm (inch)]
DN 25	PN 40	115.0 (4.53)	85.0 (3.35)	14.0 (0.55)	4	258.0 (10.16)	45.5 (1.79)	87.0 (3.43)	170.0 (6.69)	118.0 (4.65)
	PN 63 / 100	140.0 (5.51)	100.0 (3.94)	18.0 (0.71)	4	270.0 (10.63)	51.5 (2.03)	87.0 (3.43)	170.0 (6.69)	118.0 (4.65)
1"	CL 150	107.9 (4.25)	79.4 (3.13)	15.9 (0.63)	4	258.0 (10.16)	45.5 (1.79)	87.0 (3.43)	170.0 (6.69)	118.0 (4.65)
	CL 300	123.8 (4.87)	88.9 (3.50)	19.0 (0.75)	4	258.0 (10.16)	45.5 (1.79)	87.0 (3.43)	170.0 (6.69)	118.0 (4.65)
	CL 600	124.0 (4.88)	88.9 (3.50)	19.0 (0.75)	4	270.0 (10.63)	51.5 (2.03)	87.0 (3.43)	170.0 (6.69)	118.0 (4.65)
DN 50	PN 40	165.0 (6.50)	125.0 (4.92)	18.0 (0.71)	4	258.0 (10.16)	45.5 (1.79)	102.0 (4.02)	170.0 (6.69)	118.0 (4.65)
	PN 63	180.8 (7.12)	135.0 (5.31)	22.0 (0.87)	4	270.0 (10.63)	51.5 (2.03)	102.0 (4.02)	170.0 (6.69)	118.0 (4.65)
	PN 100	195.0 (7.68)	145.0 (5.71)	26.0 (1.02)	4	274.0 (10.79)	53.5 (2.11)	102.0 (4.02)	170.0 (6.69)	118.0 (4.65)
2"	CL 150	152.4 (6.00)	120.7 (4.75)	19.0 (0.75)	4	258.0 (10.16)	45.5 (1.79)	102.0 (4.02)	170.0 (6.69)	118.0 (4.65)
	CL 300	165.1 (6.50)	127.0 (5.00)	19.0 (0.75)	8	263.0 (10.35)	48.0 (1.89)	102.0 (4.02)	170.0 (6.69)	118.0 (4.65)
	CL 600	165.1 (6.50)	127.0 (5.00)	19.0 (0.75)	8	284.0 (11.18)	58.5 (2.30)	102.0 (4.02)	170.0 (6.69)	118.0 (4.65)
DN 80	PN 40	200.0 (7.87)	160.0 (6.30)	18.0 (0.71)	8	262.0 (10.31)	47.5 (1.87)	117.0 (4.61)	166.0 (6.54)	130.0 (5.12)
	PN 63	215.0 (8.46)	170.0 (6.69)	22.0 (0.87)	8	270.0 (10.63)	51.5 (2.03)	117.0 (4.61)	166.0 (6.54)	130.0 (5.12)
	PN 100	230.0 (9.06)	180.0 (7.09)	26.0 (1.02)	8	282.0 (11.10)	57.5 (2.26)	117.0 (4.61)	166.0 (6.54)	130.0 (5.12)
3"	CL 150	190.5 (7.50)	152.4 (6.00)	19.0 (0.75)	4	262.0 (10.31)	47.5 (1.87)	117.0 (4.61)	166.0 (6.54)	130.0 (5.12)
	CL 300	209.5 (8.25)	168.1 (6.62)	22.3 (0.88)	8	271.0 (10.67)	52.0 (2.05)	117.0 (4.61)	166.0 (6.54)	130.0 (5.12)
	CL 600	209.5 (8.25)	168.1 (6.62)	22.2 (0.87)	8	292.0 (11.50)	58.5 (2.30)	117.0 (4.61)	166.0 (6.54)	130.0 (5.12)

Device size	Pressure rating	Ø D	Ø k	Ø L	N	A	B	C	F	G
		[mm (inch)]	[mm (inch)]	[mm (inch)]		[mm (inch)]	[mm (inch)]	[mm (inch)]	[mm (inch)]	[mm (inch)]
DN 100	PN 40	235.0 (9.25)	190.0 (7.48)	22.0 (0.87)	8	254.0 (10.00)	43.5 (1.71)	132.0 (5.20)	168.0 (6.61)	144.0 (5.67)
	PN 63	250.0 (9.84)	200.0 (7.87)	26.0 (1.02)	8	266.0 (10.47)	49.5 (1.95)	132.0 (5.20)	168.0 (6.61)	144.0 (5.67)
	PN 100	265.0 (10.43)	210.0 (8.27)	30.0 (1.18)	8	278.0 (10.94)	55.5 (2.19)	132.0 (5.20)	168.0 (6.61)	144.0 (5.67)
4"	CL 150	228.6 (9.00)	190.5 (7.50)	19.0 (0.75)	8	254.0 (10.00)	43.5 (1.71)	132.0 (5.20)	168.0 (6.61)	144.0 (5.67)
	CL 300	254.0 (10.00)	200.1 (7.88)	22.2 (0.87)	8	270.0 (10.63)	51.5 (2.03)	132.0 (5.20)	168.0 (6.61)	144.0 (5.67)
	CL 600	273.0 (10.75)	215.9 (8.50)	25.4 (1.00)	8	290.0 (11.42)	61.5 (2.42)	132.0 (5.20)	168.0 (6.61)	144.0 (5.67)

### Weight in kg (lb)

Indicator housing material	Device size (meter tube)			
	DN 25 (1")	DN 50 (2")	DN 80 (3")	DN 100 (4")
Al Si 12	6.8 / (15)	10.7 / (23.6)	15.7 / (34.6)	34 / (75)
Stainless steel 1.4408	9.3 / (20.5)	13.2 / (29.1)	18.2 / (40.1)	36.5 / (80.4)





# VA Master FAM540 Metal Cone Variable Area Flowmeter

## Use in potentially explosive atmospheres according to ATEX and IECEx

**NOTE**  
Further information on the approval of devices for use in potentially explosive atmospheres can be found in the type examination certificates or the relevant certificates at [www.abb.com/flow](http://www.abb.com/flow).

### Device overview

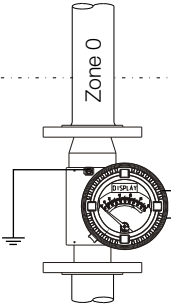
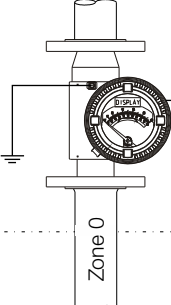
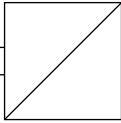
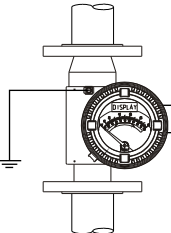
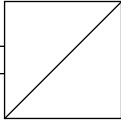
The devices are designed for maximum versatility. This is achieved through a combination of several types of protection within each device. All devices are suitable for use in potentially explosive atmospheres with combustible dust. For detailed installation instructions and terminal assignments, refer to chapter „Electrical connections“ on page 8.

Zone 1	Zone 2	Standard / No explosion protection	Order code <sup>1)</sup>					
 <p>Ex ia</p>	 <p>Ex nA</p>		<table border="1"> <tr> <td>B1 (Ex nA)</td> <td rowspan="2">A4 (Ex nA, Ex ia)</td> <td rowspan="3">A9 (Ex nA, Ex ia, Ex d)</td> </tr> <tr> <td></td> </tr> <tr> <td></td> </tr> </table> <p style="text-align: right;">G10467</p>	B1 (Ex nA)	A4 (Ex nA, Ex ia)	A9 (Ex nA, Ex ia, Ex d)		
B1 (Ex nA)	A4 (Ex nA, Ex ia)	A9 (Ex nA, Ex ia, Ex d)						
 <p>Ex d</p>								
<p> Potential equalization</p>								

1) Order code "Explosion protection and approvals" (versions 9, 10); refer to chapter „Ordering Information“ on page 50.

## Ex-marking

### NOTE

- Depending on the design, a specific marking in accordance with ATEX or IECEx applies.
- ABB reserves the right to modify the Ex-marking. Refer to the name plate for the exact marking.

Model FAM54xAx (analog indicator without alarm signaling unit)			
Labeling	Type of protection	Order code <sup>1)</sup>	Limit value table
ATEX	II 1/2 G c II T6...T1	A4, A9, B1	„Table 5“ on page 39
	II 2D c T85 °C to T <sub>medium</sub> Db		
	II 2D Ex tb IIIC T85 °C... T <sub>medium</sub> Db		

1) Order code "Explosion protection and approvals" (versions 9, 10); refer to chapter „Ordering Information“ on page 50.

Model FAM54xB/C/Dx (analog indicator with alarm signaling unit)			
Labeling	Type of protection	Order code <sup>1)</sup>	Limit value table
ATEX	II 1/2G Ex c ia IIC T6 ... T1 Ga/Gb	A4	„Table 2“ on page 36
	II 1/3G Ex c nA IIC T6 ... T1 Ga/Gc		„Table 4“ on page 38
	II 2D Ex tb IIIC T85 °C... T <sub>medium</sub> Db		„Table 2“ on page 36, „Table 4“ on page 38
IECEx	Ex ia IIC T6 ... T1 Ga/Gb	A9	„Table 2“ on page 36
	Ex nA II T6 ... T1		„Table 4“ on page 38
	Ex tb IIIC T85 °C ... T <sub>medium</sub> Db		„Table 2“ on page 36, „Table 4“ on page 38
ATEX	II 1/2G Ex c d IIC T6 ... T1 Ga/Gb	A9	„Table 3“ on page 37
	II 1/2G Ex c ia IIC T6 ... T1 Ga/Gb		„Table 2“ on page 36
	II 1/3G Ex c nA IIC T6 ... T1 Ga/Gc		„Table 4“ on page 38
	II 2D Ex tb IIIC T85 °C... T <sub>medium</sub> Db		„Table 2“ on page 36, „Table 3“ on page 37, „Table 4“ on page 38
IECEx	Ex d IIC T6 ... T1 Ga /Gb	B1	„Table 3“ on page 37
	Ex ia IIC T6 ... T1 Ga /Gb		„Table 2“ on page 36
	Ex nA IIC T6 ... T1 Ga /Gb		„Table 4“ on page 38
	Ex tb IIIC T85 °C ... T <sub>medium</sub> Db		„Table 2“ on page 36, „Table 3“ on page 37, „Table 4“ on page 38
ATEX	II 1/3G Ex c nA IIC T6 ... T1 Ga/Gc	B1	„Table 4“ on page 38
	II 2D Ex tb IIIC T85 °C... T <sub>medium</sub> Db		„Table 4“ on page 38
IECEx	Ex nA IIC T6 ... T1 Ga / Gc	B1	„Table 4“ on page 38
	Ex tb IIIC T85 °C ... T <sub>medium</sub> Db		„Table 4“ on page 38

1) Order code "Explosion protection and approvals" (versions 9, 10); refer to chapter „Ordering Information“ on page 50.

# VA Master FAM540

## Metal Cone Variable Area Flowmeter

Model FAM54xE/Fx (analog indicator with transmitter and with or without LCD indicator)				
Labeling	Type of protection	Order code <sup>1)</sup>	Limit value table	
<b>ATEX</b>	II 1/2 G Ex c ia IIC T4 ... T1 Ga/Gb	Intrinsic Safety	„Table 1“ on page 35	
	II 1/3G Ex c nA ic IIC T6 ... T1 Ga/Gc	Non-sparking materials		
	II 2 D Ex tb IIIC T85 °C... T <sub>medium</sub> Db	Dust explosion protection		
<b>IECEX</b>	Ex ia IIC T4 ... T1 Ga / Gb	Intrinsic Safety		
	Ex nA ic IIC T6 ... T1 Ga / Gc	Non-sparking materials		
	Ex tb IIIC T85 °C ... T <sub>medium</sub> Db	Dust explosion protection		
<b>ATEX</b>	II 1/2G Ex c d IIC T6 ... T1 Ga/Gb	Flameproof (enclosure)		„Table 1“ on page 35
	II 1/2 G Ex c ia IIC T4 ... T1 Ga/Gb	Intrinsic Safety		
	II 1/3G Ex c nA ic IIC T6 ... T1 Ga/Gc	Non-sparking materials		
	II 2 D Ex tb IIIC T85 °C... T <sub>medium</sub> Db	Dust explosion protection		
<b>IECEX</b>	Ex d IIC T6 ... T1 Ga / Gb	Flameproof (enclosure)		
	Ex ia IIC T4 ... T1 Ga / Gb	Intrinsic Safety		
	Ex nA ic IIC T6 ... T1 Ga / Gc	Non-sparking materials		
	Ex tb IIIC T85 °C ... T <sub>medium</sub> Db	Dust explosion protection		
<b>ATEX</b>	II 1/3G Ex c nA ic IIC T6 ... T1 Ga/Gc	Non-sparking materials	„Table 4“ on page 38	
	II 2 D Ex tb IIIC T85 °C... T <sub>medium</sub> Db	Dust explosion protection		
<b>IECEX</b>	Ex nA ic IIC T6 ... T1 Ga / Gc	Non-sparking materials		
	Ex tb IIIC T85 °C ... T <sub>medium</sub> Db	Dust explosion protection		

1) Order code "Explosion protection and approvals" (versions 9, 10); refer to chapter „Ordering Information“ on page 50.

### Safety specifications ATEX / IECEX

#### Special conditions for type of protection "Ex td" (dust explosion protection)

##### Model FAM54xB/C/D/E/Fx

The following differing temperature data applies to usage in areas with combustible dust.

Order code	Ambient temperature T <sub>amb</sub>	Maximum permissible measuring medium temperature T <sub>medium</sub>
A4, A9, B1	-50°C... +60°C	250 °C
	-50°C... +40°C	340 °C
	-50°C... +20°C	430 °C

**Table 1: Analog indicator with transmitter, with or without LCD indicator**

**Model FAM54xE/Fx**

Type of protection: flameproof enclosure, intrinsic safety, non-sparking equipment, dust explosion protection.

Order code <sup>1)</sup>	Labeling	Terminals	Electrical values	T <sub>amb</sub> -20 °C ... (-50 °C ... )	Temp. class	T <sub>medium</sub> Maximum	Insulation	Heating jacket				
A4, A9	<b>ATEX:</b> II 1/2 G Ex c ia IIC T4 ... T1 Ga/Gb II 2 D Ex tb IIIC T85 °C... T <sub>medium</sub> Db  <b>IECEx:</b> Ex ia IIC T4 ... T1 Ga / Gb Ex tb IIIC T85 °C ... T <sub>medium</sub> Db	31 / 32 <sup>2)</sup>	U <sub>i</sub> = 30 V I <sub>i</sub> = 110 mA P <sub>i</sub> = 770 mW C <sub>i</sub> = 5.3 nF L <sub>i</sub> = 266 µH	40 °C	T1	440 °C	No	No				
				40 °C	T1	375 °C	yes	No				
				40 °C	T1	260 °C	yes	yes				
				50 °C	T1	300 °C	yes	No				
				50 °C	T2	290 °C	yes	No				
				50 °C	T2	220 °C	yes	yes				
		41 / 42 <sup>2)</sup>	U <sub>i</sub> = 30 V I <sub>i</sub> = 30 mA P <sub>i</sub> = 115 mW C <sub>i</sub> = 4.8 nF L <sub>i</sub> = 133 µH	60 °C	T2	320 °C	No	No				
				60 °C	T2	230 °C	yes	No				
				60 °C	T3	170 °C	yes	yes				
				70 °C	T3	195 °C	No	No				
				70 °C	T3	150 °C	yes	No				
				70 °C	T4	125 °C	yes	yes				
				A9	<b>ATEX:</b> II 1/2G Ex c d IIC T6 ... T1 Ga/Gb II 2 D Ex tb IIIC T85 °C... T <sub>medium</sub> Db  <b>IECEx:</b> Ex d IIC T6 ... T1 Ga / Gb Ex tb IIIC T85 °C ... T <sub>medium</sub> Db	31 / 32 <sup>3)</sup>	U <sub>max</sub> = 46 V	40 °C	T1	440 °C	No	No
								40 °C	T1	375 °C	yes	No
40 °C	T1	260 °C	yes					yes				
50 °C	T1	300 °C	yes					No				
50 °C	T2	290 °C	yes					No				
50 °C	T2	220 °C	yes					yes				
41 / 42 <sup>3)</sup>	U <sub>max</sub> = 30 V I <sub>max</sub> = 30 mA P <sub>max</sub> = 115 mW	60 °C	T2			320 °C	No	No				
		60 °C	T2			230 °C	yes	No				
		60 °C	T3			170 °C	yes	yes				
		60 °C	T4			130 °C	yes	yes				
		60 °C	T5			95 °C	yes	yes				
		60 °C	T6			80 °C	yes	yes				
		A4, A9, B1	<b>ATEX:</b> II 1/3G Ex c nA ic IIC T6 ... T1 Ga/Gc II 2 D Ex tb IIIC T85 °C... T <sub>medium</sub> Db  <b>IECEx:</b> Ex nA ic IIC T6 ... T1 Ga / Gc Ex tb IIIC T85 °C ... T <sub>medium</sub> Db			31 / 32 <sup>3)</sup>	U <sub>max</sub> = 46 V	40 °C	T1	440 °C	No	No
								40 °C	T1	375 °C	yes	No
40 °C	T1			260 °C	yes			yes				
50 °C	T1			300 °C	yes			No				
50 °C	T2			290 °C	yes			No				
50 °C	T2			220 °C	yes			yes				
41 / 42 <sup>3)</sup>	U <sub>max</sub> = 30 V I <sub>max</sub> = 30 mA P <sub>max</sub> = 115 mW			60 °C	T2	320 °C	No	No				
				60 °C	T2	230 °C	yes	No				
				60 °C	T3	170 °C	yes	yes				
				70 °C	T3	195 °C	No	No				
				70 °C	T3	150 °C	yes	No				
				70 °C	T4	130 °C	yes	yes				

1) Order code "Explosion protection and approvals" (versions 9, 10); refer to chapter „Ordering Information“ on page 50.

2) For connection to an intrinsically safe circuit.

3) For connection to a non-intrinsically safe circuit. If the device is to be operated subsequently with type of protection "intrinsically safe", then U<sub>max</sub> = 60 V may not be exceeded.

# VA Master FAM540

## Metal Cone Variable Area Flowmeter

**Table 2: Analog indicator with alarm signaling unit**

**Model FAM54xB/C/Dx**

Type of protection: intrinsic safety, dust explosion protection.

Order code <sup>1)</sup>	Labeling	Terminals	Electrical values	T <sub>amb</sub> -20 °C ... (-50 °C ... )	Temp. class	T <sub>medium</sub> Maximum	Insulation	Heating jacket
A4, A9	<b>ATEX:</b> II 1/2G Ex c ia IIC T6 ... T1 Ga/Gb II 2D Ex tb IIIC T85 °C... T <sub>medium</sub> Db  <b>IECEX:</b> Ex ia IIC T6 ... T1 Ga / Gb Ex tb IIIC T85 °C ... T <sub>medium</sub> Db	41 / 42 <sup>2)</sup> 51 / 52 <sup>2)</sup>	U <sub>i</sub> = 16 V I <sub>i</sub> = 25 mA P <sub>i</sub> = 64 mW C <sub>i</sub> = 50 nF L <sub>i</sub> = 250 µH	40 °C	T1	440 °C	No	No
				40 °C	T1	375 °C	yes	No
				40 °C	T1	260 °C	yes	yes
				50 °C	T1	300 °C	yes	No
				50 °C	T2	290 °C	yes	No
				50 °C	T2	220 °C	yes	yes
				60 °C	T2	320 °C	No	No
				60 °C	T2	230 °C	yes	No
				60 °C	T3	170 °C	yes	yes
				70 °C	T3	195 °C	No	No
				70 °C	T3	150 °C	yes	No
				70 °C	T4	130 °C	yes	yes
		70 °C	T5	95 °C	yes	yes		
		60 °C	T6	80 °C	yes	yes		
		41 / 42 <sup>2)</sup> 51 / 52 <sup>2)</sup>	U <sub>i</sub> = 16 V I <sub>i</sub> = 52 mA P <sub>i</sub> = 169 mW C <sub>i</sub> = 50 nF L <sub>i</sub> = 250 µH	40 °C	T1	440 °C	No	No
				40 °C	T1	375 °C	yes	No
				40 °C	T1	260 °C	yes	yes
				50 °C	T1	300 °C	yes	No
				50 °C	T2	290 °C	yes	No
				50 °C	T2	220 °C	yes	yes
				60 °C	T2	320 °C	No	No
				60 °C	T2	230 °C	yes	No
				60 °C	T3	170 °C	yes	yes
				70 °C	T3	195 °C	No	No
				70 °C	T3	150 °C	yes	No
				70 °C	T4	130 °C	yes	yes
		60 °C	T5	60 °C	yes	yes		
		50 °C	T5	90 °C	No	yes		
		40 °C	T6	60 °C	yes	yes		
		41 / 42 <sup>2)</sup> 51 / 52 <sup>2)</sup>	U <sub>i</sub> = 16 V I <sub>i</sub> = 76 mA P <sub>i</sub> = 242 mW C <sub>i</sub> = 50 nF L <sub>i</sub> = 250 µH	40 °C	T1	440 °C	No	No
40 °C	T1			310 °C	yes	No		
40 °C	T2			190 °C	yes	yes		
50 °C	T2			340 °C	No	No		
50 °C	T2			230 °C	yes	yes		
60 °C	T2			230 °C	No	No		
60 °C	T3			160 °C	yes	yes		
70 °C	T4			120 °C	No	No		
70 °C	T4			100 °C	yes	yes		
40 °C	T5			60 °C	yes	yes		
30 °C	T6			30 °C	yes	yes		

1) Order code "Explosion protection and approvals" (versions 9, 10); refer to chapter „Ordering Information“ on page 50.

2) For connection to an intrinsically safe circuit.

**Table 3: Analog indicator with alarm signaling unit**

**Model FAM54xB/C/Dx**

Type of protection: flameproof enclosure, dust explosion protection.

Order code <sup>1)</sup>	Labeling	Terminals	Electrical values	T <sub>amb</sub> -20 °C ... (-50 °C ...)	Temp. class	T <sub>medium</sub> Maximum	Insulation	Heating jacket
A9	<b>ATEX:</b> II 1/2G Ex c d IIC T6 ... T1 Ga/Gb II 2D Ex tb IIIC T85 °C... T <sub>medium</sub> Db  <b>IECEx:</b> Ex d IIC T6 ... T1 Ga / Gb Ex tb IIIC T85 °C ... T <sub>medium</sub> Db	41 / 42 <sup>2)</sup> 51 / 52 <sup>2)</sup>	U <sub>max</sub> = 16 V I <sub>max</sub> = 25 mA P <sub>max</sub> = 64 mW	40 °C	T1	440 °C	No	No
				40 °C	T1	375 °C	yes	No
				40 °C	T1	260 °C	yes	yes
				50 °C	T1	300 °C	yes	No
				50 °C	T2	290 °C	yes	No
				50 °C	T2	220 °C	yes	yes
				60 °C	T2	320 °C	No	No
				60 °C	T2	230 °C	yes	No
				60 °C	T3	170 °C	yes	yes
				70 °C	T3	195 °C	No	No
				70 °C	T3	150 °C	yes	No
				70 °C	T4	130 °C	yes	yes
				70 °C	T5	95 °C	yes	yes
				60 °C	T6	80 °C	yes	yes
				41 / 42 <sup>2)</sup> 51 / 52 <sup>2)</sup>	U <sub>max</sub> = 16 V I <sub>max</sub> = 52 mA P <sub>max</sub> = 169 mW	40 °C	T1	440 °C
		40 °C	T1			375 °C	yes	No
		40 °C	T1			260 °C	yes	yes
		50 °C	T1			300 °C	yes	No
		50 °C	T2			290 °C	yes	No
		50 °C	T2			220 °C	yes	yes
		60 °C	T2			320 °C	No	No
		60 °C	T2			230 °C	yes	No
		60 °C	T3			170 °C	yes	yes
		70 °C	T3			195 °C	No	No
		70 °C	T3			150 °C	yes	No
		70 °C	T4			130 °C	yes	yes
		60 °C	T5			60 °C	yes	yes
		50 °C	T5			90 °C	No	yes
		40 °C	T6			60 °C	yes	yes
		41 / 42 <sup>2)</sup> 51 / 52 <sup>2)</sup>	U <sub>max</sub> = 16 V I <sub>max</sub> = 76 mA P <sub>max</sub> = 242 mW	40 °C	T1	440 °C	No	No
40 °C	T1			310 °C	yes	No		
40 °C	T2			190 °C	yes	yes		
50 °C	T2			340 °C	No	No		
50 °C	T2			230 °C	yes	yes		
60 °C	T2			230 °C	No	No		
60 °C	T3			160 °C	yes	yes		
70 °C	T4			120 °C	No	No		
70 °C	T4			100 °C	yes	yes		
40 °C	T5			60 °C	yes	yes		
30 °C	T6			30 °C	yes	yes		

1) Order code "Explosion protection and approvals" (versions 9, 10); refer to chapter „Ordering Information" on page 50.

2) For connection to a non-intrinsically safe circuit. If the device is to be operated subsequently with type of protection "intrinsically safe", then U<sub>max</sub> = 60 V may not be exceeded.

# VA Master FAM540

## Metal Cone Variable Area Flowmeter

**Table 4: Analog indicator with alarm signaling unit**

**Model FAM54xB/C/Dx**

Type of protection: non-sparking materials, dust explosion protection.

Order code <sup>1)</sup>	Labeling	Terminals	Electrical values	T <sub>amb</sub> -20 °C ... (-50 °C ... )	Temp. class	T <sub>medium</sub> Maximum	Insulation	Heating jacket
A4, A9, B1	<b>ATEX:</b> II 1/3G Ex c nA IIC T6 ... T1 Ga/Gc II 2D Ex tb IIIC T85 °C... T <sub>medium</sub> Db  <b>IECEX:</b> Ex nA IIC T6 ... T1 Ga / Gc Ex tb IIIC T85 °C ... T <sub>medium</sub> Db	41 / 42 <sup>2)</sup> 51 / 52 <sup>2)</sup>	U <sub>max</sub> = 16 V I <sub>max</sub> = 25 mA P <sub>max</sub> = 64 mW	40 °C	T1	440 °C	No	No
				40 °C	T1	375 °C	yes	No
				40 °C	T1	260 °C	yes	yes
				50 °C	T1	300 °C	yes	No
				50 °C	T2	290 °C	yes	No
				50 °C	T2	220 °C	yes	yes
				60 °C	T2	320 °C	No	No
				60 °C	T2	230 °C	yes	No
				60 °C	T3	170 °C	yes	yes
				70 °C	T3	195 °C	No	No
		70 °C	T3	150 °C	yes	No		
		70 °C	T4	130 °C	yes	yes		
		70 °C	T5	95 °C	yes	yes		
		60 °C	T6	80 °C	yes	yes		
		41 / 42 <sup>2)</sup> 51 / 52 <sup>2)</sup>	U <sub>max</sub> = 16 V I <sub>max</sub> = 52 mA P <sub>max</sub> = 169 mW	40 °C	T1	440 °C	No	No
				40 °C	T1	375 °C	yes	No
				40 °C	T1	260 °C	yes	yes
				50 °C	T1	300 °C	yes	No
				50 °C	T2	290 °C	yes	No
				50 °C	T2	220 °C	yes	yes
60 °C	T2			320 °C	No	No		
60 °C	T2			230 °C	yes	No		
60 °C	T3			170 °C	yes	yes		
70 °C	T3			195 °C	No	No		
70 °C	T3	150 °C	yes	No				
70 °C	T4	130 °C	yes	yes				
60 °C	T5	60 °C	yes	yes				
50 °C	T5	90 °C	No	yes				
40 °C	T6	60 °C	yes	yes				
A4, A9, B1	<b>ATEX:</b> II 1/3G Ex c nA IIC T6 ... T1 Ga/Gc II 2D Ex tb IIIC T85 °C... T <sub>medium</sub> Db  <b>IECEX:</b> Ex nA IIC T6 ... T1 Ga / Gc Ex tb IIIC T85 °C ... T <sub>medium</sub> Db	41 / 42 <sup>2)</sup> 51 / 52 <sup>2)</sup>	U <sub>max</sub> = 16 V I <sub>max</sub> = 76 mA P <sub>max</sub> = 242 mW	40 °C	T1	440 °C	No	No
				40 °C	T1	310 °C	yes	No
				40 °C	T2	190 °C	yes	yes
				50 °C	T2	340 °C	No	No
				50 °C	T2	230 °C	yes	yes
				60 °C	T2	230 °C	No	No
				60 °C	T3	160 °C	yes	yes
				70 °C	T4	120 °C	No	No
				70 °C	T4	100 °C	yes	yes
				40 °C	T5	60 °C	yes	yes
				30 °C	T6	30 °C	yes	yes

1) Order code "Explosion protection and approvals" (versions 9, 10); refer to chapter „Ordering Information" on page 50.

2) For connection to a non-intrinsically safe circuit. If the device is to be operated subsequently with type of protection "intrinsically safe", then U<sub>max</sub> = 60 V may not be exceeded.

**Table 5: Analog indicator without alarm signaling unit**

**Model FAM54xAx**

Type of protection: constructional safety, dust explosion protection

Order code <sup>1)</sup>	Labeling	Terminals	Electrical values	T <sub>amb</sub> -20 °C ... (-50 °C ...)	Temp. class	T <sub>medium</sub> Maximum	Insulation	Heating jacket
A4, A9, B1	<b>ATEX:</b> II 1/2 G c II T6...T1 II 2D c T85 °C to T <sub>medium</sub> II 2D Ex tb IIIC T85 °C... T <sub>medium</sub> Db <b>IECEX:</b> Ex tb IIIC T85 °C ... T <sub>medium</sub> Db	n.a.	n.a.	70 °C	T1	440 °C	yes	yes
70 °C				T2	290 °C	yes	yes	
70 °C				T3	190 °C	yes	yes	
70 °C				T4	130 °C	yes	yes	
70 °C				T5	95 °C	yes	yes	
70 °C				T6	80 °C	yes	yes	

**Electrical connections**

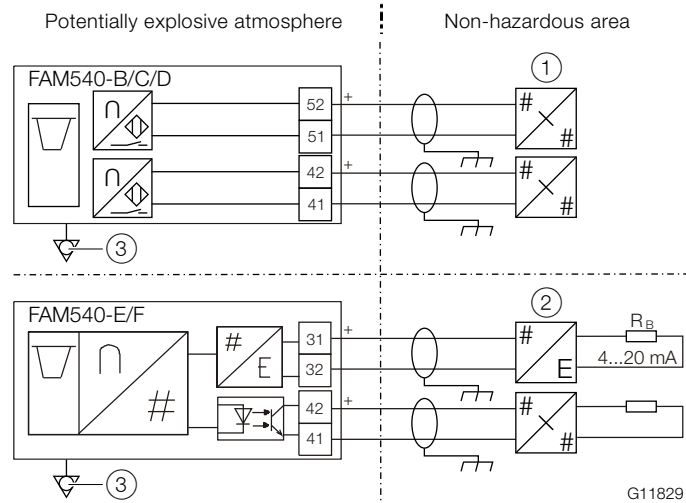

**Fig. 25: ATEX / IECEx electrical connection**  
 ① NAMUR switching amplifier ② Safety barrier  
 ③ Potential equalization

Terminal	Function
31 / 32	Power supply / current output / HART output
41 / 42	Programmable binary output Alarm signaling unit (min.)
51 / 52	Alarm signaling unit (max.)

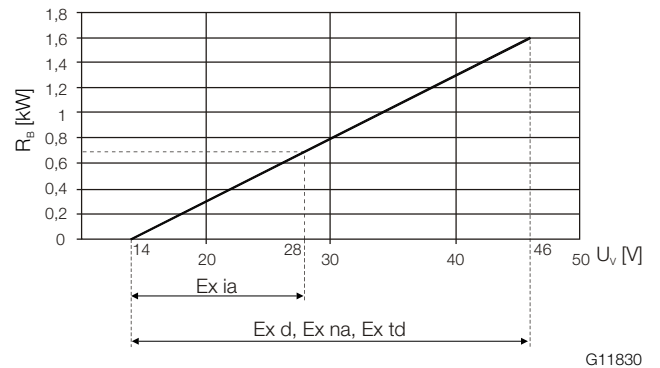

**Fig. 26: Terminals 31 / 32, power supply / load**  
 U<sub>V</sub> Power supply  
 R<sub>B</sub> Maximum permissible load in the power supply (e.g. indicator)  
 The minimum voltage U<sub>V</sub> = 0 V is based on a load of 0 Ω.



# VA Master FAM540

## Metal Cone Variable Area Flowmeter

### Signal cable

The Ex calculations are based on temperatures of 80 °C (176 °F) at the cable input. For this reason, cables with a specification of 80 °C (176 °F) must be used.

For cables limited to 70 °C (158 °F), a maximum ambient temperature of  $T_{amb} = 60$  °C (140 °F) applies.

The resulting new maximum measuring medium temperatures are determined as follows:

- Calculate a new ambient temperature:  
 $T_{amb\ new} = T_{amb} + 10$  °C (18 °F).
- Use the calculated ambient temperature  $T_{amb\ new}$  to determine the new associated permissible measuring medium temperatures in the tables.
- Please use the limit value tables with the original ambient temperature  $T_{amb}$  to determine the relevant temperature class. See chapter „Safety specifications ATEX / IECEx“ on page 34, Tables 1 through 5.

### Example:

- $T_{amb} = 50$  °C (122 °F) becomes  
 $T_{amb\ new} = 60$  °C (140 °F).
- Determine the measuring medium temperature  
 $T_{amb} = 60$  °C (140 °F).
- Determine the temperature class for  
 $T_{amb} = 50$  °C (122 °F).

### Earthing

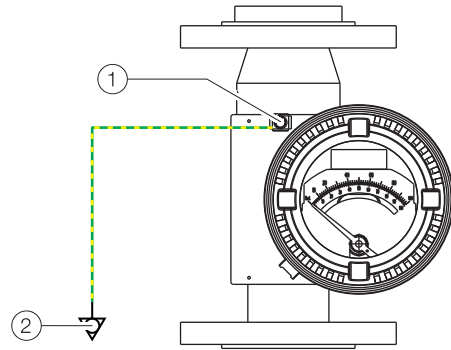

G10433

Fig. 27: Earthing

- ① Earthing terminal
- ② Potential equalization in accordance with EN 60079-0

The FAM540 housing must be correctly earthed in order to ensure proper function and safe operation.

Copper wires with a minimum cross-section of 6 mm<sup>2</sup> (AWG 10) must be used to connect to the potential equalization.

---

### **i** NOTE

---

The operator must ensure that when connecting the protective earth (PE), there are no potential differences between protective earth (PE) and potential equalization, even in the event of a fault.

---

## Use in potentially explosive atmospheres in accordance with FM and cCSAus

### NOTE

Further information on the approval of devices for use in potentially explosive atmospheres can be found in the type examination certificates or the relevant certificates at [www.abb.com/flow](http://www.abb.com/flow).

### Ex-marking

### NOTE

- Depending on the design, a specific marking in accordance with FM applies.
- ABB reserves the right to modify the Ex-marking. Refer to the name plate for the exact marking.

Model FAM54xAx (analog indicator without alarm signaling unit and model FAM54xB/C/Dx (analog indicator with alarm signaling unit))				
Labeling	Type of protection	Order code <sup>1)</sup>	Limit value table	
<b>FM</b>	XP / CL I / DIV 1 / GP ABCD / T6...T1 CL I, ZN 1 AEx d IIC T6...T1	Explosionproof	F3	„Table 2“ on page 44
	IS / CL I,II,III / DIV 1 / GP ABCDEFG / T6..T1 CL I, ZN 1 AEx ia IIC T6...T1	Intrinsic Safety	F3, F4	„Table 1“ on page 43, „Table 2“ on page 44
	DIP / CL II, III / DIV 1 / GP EFG / T6...T1	Dust-Ignitionproof		
	NI / CL I,II / DIV 2 / GP ABCDFG / T5...T1 NI / CL III T5...T1 CL II, ZN 2 AEx nA II T5...T1	Non-Incendive	F3, F4	„Table 1“ on page 43, „Table 2“ on page 44, „Table 3“ on page 45
	<b>cCSAus</b>	XP / CL I / DIV 1 / GP BCD / T6...T1 Ex d IIC T6...T1	Explosionproof	F3
	IS / CL I,II,III / DIV 1 / GP ABCDEFG / T6..T1 Ex ia IIC T6...T1	Intrinsic Safety	F3, F4	„Table 1“ on page 43,
	DIP / CL II, III / DIV 1 / GP EFG / T6...T1 DIP A21 TA 85°C to T <sub>medium</sub>	Dust-Ignitionproof	F3, F4	„Table 1“ on page 43, „Table 2“ on page 44, „Table 3“ on page 45
	NI / CL I,II / DIV 2 / GP ABCDFG / T5...T1 NI / CL III T5...T1 Ex nA II T5...T1	Non-Incendive	F3, F4	„Table 3“ on page 45

1) Order code "Explosion protection and approvals" (version digit No. 9, 10); refer to chapter „Ordering Information“ on page 50.

# VA Master FAM540

## Metal Cone Variable Area Flowmeter

Model FAM54xE/Fx (analog indicator with transmitter / with or without LCD display)					
Labeling	Type of protection	Order code <sup>1)</sup>	Limit value table		
<b>FM</b>	XP / CL I / DIV 1 / GP ABCD / T6...T1 CL I, ZN 1 AEx d IIC T6...T1	Explosionproof	F3	„Table 4“ on page 46	
	IS / CL I,II,III / DIV 1 / GP ABCDEFG / T4..T1 CL I, ZN 1 AEx ia IIC T4...T1	Intrinsic Safety	F3, F4		
	DIP / CL II, III / DIV 1 / GP EFG / T6...T1	Dust-Ignitionproof			
	NI / CL I,II / DIV 2 / GP ABCDFG / T4...T1 NI / CL III T4...T1 CL II, ZN 2 AEx nA [nL] IIC T6...T1	Non-Incendive			
	<b>cCSAus</b>	XP / CL I / DIV 1 / GP BCD / T6...T1 Ex d IIC T6...T1	Explosionproof		F3
		IS / CL I,II,III / DIV 1 / GP ABCDEFG / T4..T1 Ex ia IIC T4...T1	Intrinsic Safety		F3, F4
DIP / CL II, III / DIV 1 / GP EFG / T6...T1 DIP A21 TA 85°C to T <sub>medium</sub>		Dust-Ignitionproof			
NI / CL I,II / DIV 2 / GP ABCDFG / T4...T1 NI / CL III T4...T1 Ex nA [nL] IIC T6...T1		Non-Incendive			

1) Order code "Explosion protection and approvals" (version digit No. 9, 10); refer to chapter „Ordering Information“ on page 50.

## Safety specifications FM, cCSAus

**Table 1: Analog indicator with alarm signaling unit (temperature data for FM in °F, for cCSAus in °C)**

Order code <sup>1)</sup>	Labeling	Terminals	Electrical values	T <sub>amb</sub> -58 °F ...	T <sub>amb</sub> -50 °C ...	Temp. class	T <sub>medium</sub> Maximum	Insulation	Heating jacket
F3, F4	<b>FM</b> IS / CL I,II,III / DIV 1 / GP ABCDEFG / T6...T1 <sup>2)</sup>  DIP / CL II, III / DIV 1 / GP EFG / T6...T1  CL I, ZN 1 AEx ia IIC T6...T1	41 / 42 <sup>3)</sup> 51 / 52 <sup>3)</sup>	U <sub>i</sub> = 16 V I <sub>i</sub> = 25 mA P <sub>i</sub> = 64 mW C <sub>i</sub> = 50 nF L <sub>i</sub> = 250 µH	104 °F	40 °C	T1	824 °F 440 °C	No	No
				104 °F	40 °C	T1	707 °F 375 °C	yes	No
				104 °F	40 °C	T1	500 °F 260 °C	yes	yes
				122 °F	50 °C	T1	572 °F 300 °C	yes	No
				122 °F	50 °C	T2	554 °F 290 °C	yes	No
				122 °F	50 °C	T2	428 °F 220 °C	yes	yes
				140 °F	60 °C	T2	608 °F 320 °C	No	No
				140 °F	60 °C	T2	446 °F 230 °C	yes	No
				140 °F	60 °C	T3	338 °F 170 °C	yes	yes
				158 °F	70 °C	T3	383 °F 195 °C	No	No
				158 °F	70 °C	T3	302 °F 150 °C	yes	No
				158 °F	70 °C	T4	266 °F 130 °C	yes	yes
				158 °F	70 °C	T5	203 °F 95 °C	yes	yes
				140 °F	60 °C	T6	176 °F 80 °C	yes	yes
				<b>cCSAus</b> IS / CL I,II,III / DIV 1 / GP ABCDEFG / T6...T1 <sup>2)</sup>  DIP / CL II, III / DIV 1 / GP EFG / T6...T1  Ex ia IIC T6...T1  DIP A21 TA 85°C to T <sub>medium</sub>	41 / 42 <sup>3)</sup> 51 / 52 <sup>3)</sup>	U <sub>i</sub> = 16 V I <sub>i</sub> = 52 mA P <sub>i</sub> = 169 mW C <sub>i</sub> = 50 nF L <sub>i</sub> = 250 µH	104 °F	40 °C	T1
	104 °F	40 °C	T1				707 °F 375 °C	yes	No
	104 °F	40 °C	T1				500 °F 260 °C	yes	yes
	122 °F	50 °C	T1				572 °F 300 °C	yes	No
	122 °F	50 °C	T2				554 °F 290 °C	yes	No
	122 °F	50 °C	T2				428 °F 220 °C	yes	yes
	140 °F	60 °C	T2				608 °F 320 °C	No	No
	140 °F	60 °C	T2				446 °F 230 °C	yes	No
	140 °F	60 °C	T3				338 °F 170 °C	yes	yes
	158 °F	70 °C	T3				383 °F 195 °C	No	No
	158 °F	70 °C	T3				302 °F 150 °C	yes	No
	158 °F	70 °C	T4				266 °F 130 °C	yes	yes
	140 °F	60 °C	T5				140 °F 60 °C	yes	yes
	122 °F	50 °C	T5				194 °F 90 °C	No	yes
	104 °F	40 °C	T6				140 °F 60 °C	yes	yes
		41 / 42 <sup>3)</sup> 51 / 52 <sup>3)</sup>	U <sub>i</sub> = 16 V I <sub>i</sub> = 76 mA P <sub>i</sub> = 242 mW C <sub>i</sub> = 50 nF L <sub>i</sub> = 250 µH	104 °F	40 °C	T1	824 °F 440 °C	No	No
104 °F				40 °C	T1	590 °F 310 °C	yes	No	
104 °F				40 °C	T2	374 °F 190 °C	yes	yes	
122 °F				50 °C	T2	644 °F 340 °C	No	No	
122 °F				50 °C	T2	446 °F 230 °C	yes	yes	
140 °F				60 °C	T2	446 °F 230 °C	No	No	
140 °F				60 °C	T3	320 °F 160 °C	yes	yes	
158 °F				70 °C	T4	248 °F 120 °C	No	No	
158 °F				70 °C	T4	212 °F 100 °C	yes	yes	
104 °F				40 °C	T5	140 °F 60 °C	yes	yes	
86 °F				30 °C	T6	86 °F 30 °C	yes	yes	

1) Order code "Explosion protection and approvals" (versions 9, 10); refer to chapter „Ordering Information“ on page 50.

2) "IS" installation in accordance with Installation Drawing SDM-10-A0253.

3) For connection to an intrinsically safe circuit.

# VA Master FAM540

## Metal Cone Variable Area Flowmeter

**Table 2: Analog indicator with alarm signaling unit (temperature data for FM in °F, for cCSAus in °C)**

Order code <sup>1)</sup>	Labeling	Terminals	Electrical values	T <sub>amb</sub> -58 °F ...	T <sub>amb</sub> -50 °C ...	Temp. class	T <sub>medium</sub> Maximum		Insulation	Heating jacket
F3	<b>FM</b> XP / CL I / DIV 1 / GP ABCD / T6...T1  DIP / CL II, III / DIV 1 / GP EFG / T6...T1  CL I, ZN 1 AEx d IIC T6...T1	41 / 42 <sup>2)</sup> 51 / 52 <sup>2)</sup>	U <sub>max</sub> = 16 V I <sub>max</sub> = 25 mA P <sub>max</sub> = 64 mW	104 °F	40 °C	T1	824 °F	440 °C	No	No
				104 °F	40 °C	T1	707 °F	375 °C	yes	No
				104 °F	40 °C	T1	500 °F	260 °C	yes	yes
				122 °F	50 °C	T1	572 °F	300 °C	yes	No
				122 °F	50 °C	T2	554 °F	290 °C	yes	No
				122 °F	50 °C	T2	428 °F	220 °C	yes	yes
				140 °F	60 °C	T2	608 °F	320 °C	No	No
				140 °F	60 °C	T2	446 °F	230 °C	yes	No
				140 °F	60 °C	T3	338 °F	170 °C	yes	yes
				158 °F	70 °C	T3	383 °F	195 °C	No	No
				158 °F	70 °C	T3	302 °F	150 °C	yes	No
				158 °F	70 °C	T4	266 °F	130 °C	yes	yes
				158 °F	70 °C	T5	203 °F	95 °C	yes	yes
				140 °F	60 °C	T6	176 °F	80 °C	yes	yes
				Ex d IIC T6...T1  DIP A21 TA 85°C to T <sub>medium</sub>	41 / 42 <sup>2)</sup> 51 / 52 <sup>2)</sup>	U <sub>max</sub> = 16 V I <sub>max</sub> = 52 mA P <sub>max</sub> = 169 mW	104 °F	40 °C	T1	824 °F
	104 °F	40 °C	T1				707 °F	375 °C	yes	No
	104 °F	40 °C	T1				500 °F	260 °C	yes	yes
	122 °F	50 °C	T1				572 °F	300 °C	yes	No
	122 °F	50 °C	T2				554 °F	290 °C	yes	No
	122 °F	50 °C	T2				428 °F	220 °C	yes	yes
	140 °F	60 °C	T2				608 °F	320 °C	No	No
	140 °F	60 °C	T2				446 °F	230 °C	yes	No
	140 °F	60 °C	T3				338 °F	170 °C	yes	yes
	158 °F	70 °C	T3				383 °F	195 °C	No	No
	158 °F	70 °C	T3				302 °F	150 °C	yes	No
	158 °F	70 °C	T4				266 °F	130 °C	yes	yes
	140 °F	60 °C	T5				140 °F	60 °C	yes	yes
	122 °F	50 °C	T5				194 °F	90 °C	No	yes
	104 °F	40 °C	T6				140 °F	60 °C	yes	yes
	41 / 42 <sup>2)</sup> 51 / 52 <sup>2)</sup>	U <sub>max</sub> = 16 V I <sub>max</sub> = 76 mA P <sub>max</sub> = 242 mW	104 °F	40 °C	T1	824 °F	440 °C	No	No	
104 °F			40 °C	T1	590 °F	310 °C	yes	No		
104 °F			40 °C	T2	374 °F	190 °C	yes	yes		
122 °F			50 °C	T2	644 °F	340 °C	No	No		
122 °F			50 °C	T2	446 °F	230 °C	yes	yes		
140 °F			60 °C	T2	446 °F	230 °C	No	No		
140 °F			60 °C	T3	320 °F	160 °C	yes	yes		
158 °F			70 °C	T4	248 °F	120 °C	No	No		
158 °F			70 °C	T4	212 °F	100 °C	yes	yes		
104 °F			40 °C	T5	140 °F	60 °C	yes	yes		
86 °F	30 °C	T6	86 °F	30 °C	yes	yes				

1) Order code "Explosion protection and approvals" (versions 9, 10); refer to chapter „Ordering Information" on page 50.

2) For connection to a non-intrinsically safe circuit.

Table 3: Analog indicator with / without alarm signaling unit (temperature data for FM in °F, for cCSAus in °C)											
Order code <sup>1)</sup>	Labeling	Terminals	Electrical values	T <sub>amb</sub>	T <sub>amb</sub>	Temp. class	T <sub>medium</sub>		Insulation	Heating jacket	
				-58 °F ...	-50 °C ...		Maximum				
F3 <sup>2)</sup>	<b>FM</b> NI / CL I,II / DIV 2 / GP ABCDFG / T5...T1  NI / CL III / T5...T1  CL II, ZN 2 AEx nA II T5...T1  <b>cCSAus</b> NI / CL I,II / DIV 2 / GP ABCDFG / T5...T1  NI / CL III / T5...T1  Ex nA II T6...T1  DIP A21 TA 85°C to T <sub>medium</sub>	41 / 42 <sup>3)</sup> 51 / 52 <sup>3)</sup>	U <sub>max</sub> = 16 V I <sub>max</sub> = 25 mA P <sub>max</sub> = 64 mW	104 °F	40 °C	T1	824 °F	440 °C	No	No	
F4 <sup>2)</sup>				104 °F	40 °C	T1	707 °F	375 °C	yes	No	
				104 °F	40 °C	T1	500 °F	260 °C	yes	yes	
				122 °F	50 °C	T1	572 °F	300 °C	yes	No	
				122 °F	50 °C	T2	554 °F	290 °C	yes	No	
				122 °F	50 °C	T2	428°F	220°C	yes	yes	
				140 °F	60 °C	T2	608 °F	320 °C	No	No	
				140 °F	60 °C	T2	446 °F	230 °C	yes	No	
				140 °F	60 °C	T3	338 °F	170 °C	yes	yes	
		158 °F	70 °C	T3	383 °F	195 °C	No	No			
		158 °F	70 °C	T3	302 °F	150 °C	yes	No			
		158 °F	70 °C	T4	266 °F	130 °C	yes	yes			
		158 °F	70 °C	T5	203 °F	95 °C	yes	yes			
			41 / 42 <sup>3)</sup> 51 / 52 <sup>3)</sup>	U <sub>max</sub> = 16 V I <sub>max</sub> = 52 mA P <sub>max</sub> = 169 mW	104 °F	40 °C	T1	824 °F	440 °C	No	No
		104 °F			40 °C	T1	707 °F	375 °C	yes	No	
		104 °F			40 °C	T1	500 °F	260 °C	yes	yes	
		122 °F			50 °C	T1	572 °F	300 °C	yes	No	
		122 °F			50 °C	T2	554 °F	290 °C	yes	No	
		122 °F			50 °C	T2	428°F	220°C	yes	yes	
	140 °F	60 °C			T2	608 °F	320 °C	No	No		
	140 °F	60 °C			T2	446 °F	230 °C	yes	No		
	140 °F	60 °C			T3	338 °F	170 °C	yes	yes		
	158 °F	70 °C	T3	383 °F	195 °C	No	No				
	158 °F	70 °C	T3	302 °F	150 °C	yes	No				
	158 °F	70 °C	T4	266 °F	130 °C	yes	yes				
	140 °F	60 °C	T5	140 °F	60 °C	yes	yes				
	122 °F	50 °C	T5	194 °F	90 °C	No	yes				
		41 / 42 <sup>3)</sup> 51 / 52 <sup>3)</sup>	U <sub>max</sub> = 16 V I <sub>max</sub> = 76 mA P <sub>max</sub> = 242 mW	104 °F	40 °C	T1	824 °F	440°C	No	No	
	104 °F			40 °C	T1	590 °F	310 °C	yes	No		
	104 °F			40 °C	T2	374 °F	190 °C	yes	yes		
	122 °F			50 °C	T2	644 °F	340 °C	No	No		
	122 °F			50 °C	T2	446°F	230 °C	yes	yes		
	140 °F			60 °C	T2	446°F	230 °C	No	No		
	140 °F			60 °C	T3	320 °F	160 °C	yes	yes		
	158 °F			70 °C	T4	248 °F	120 °C	No	No		
	158 °F			70 °C	T4	212 °F	100 °C	yes	yes		
	104 °F	40 °C	T5	140 °F	60 °C	yes	yes				

1) Order code "Explosion protection and approvals" (versions 9, 10); refer to chapter „Ordering Information“ on page 50.

2) For connection in Division 2 or Zone 2.

3) For connection to a non-intrinsically safe circuit.

# VA Master FAM540

## Metal Cone Variable Area Flowmeter

**Table 4: Analog indicator with transmitter, with or without LCD indicator (temperature data for FM in °F, for cCSAus in °C)**

Order code <sup>1)</sup>	Labeling	Terminals	Electrical values	T <sub>amb</sub> -58 °F ...	T <sub>amb</sub> -50 °C ...	Temp. class	T <sub>medium</sub> Maximum		Insulation	Heating jacket				
F3, F4	<b>FM</b> IS / CL I,II,III / DIV 1 / GP ABCDEFG / T4...T1 DIP / CL II, III / DIV 1 / GP EFG / T6...T1 CL I, ZN 1 AEx ia IIC T4...T1  <b>cCSAus</b> IS / CL I,II,III / DIV 1 / GP ABCDEFG / T4...T1 <sup>2)</sup> DIP / CL II, III / DIV 1 / GP EFG / T6...T1 Ex ia IIC T6...T1 DIP A21 TA 85°C to T <sub>medium</sub>	31 / 32 <sup>2) 3)</sup>	U <sub>i</sub> = 30 V I <sub>i</sub> = 110 mA P <sub>i</sub> = 770 mW C <sub>i</sub> = 5.3 nF L <sub>i</sub> = 266 µH	104 °F	40 °C	T1	824 °F	440 °C	No	No				
				104 °F	40 °C	T1	707 °F	375 °C	yes	No				
				104 °F	40 °C	T1	500 °F	260 °C	yes	yes				
				122 °F	50 °C	T1	572 °F	300 °C	yes	No				
				122 °F	50 °C	T2	554 °F	290 °C	yes	No				
				122 °F	50 °C	T2	428°F	220°C	yes	yes				
		41 / 42 <sup>2)</sup>	U <sub>i</sub> = 30 V I <sub>i</sub> = 30 mA P <sub>i</sub> = 115 mW C <sub>i</sub> = 4.8 nF L <sub>i</sub> = 133 µH	140 °F	60 °C	T2	608 °F	320 °C	No	No				
				140 °F	60 °C	T2	446 °F	230 °C	yes	No				
				140 °F	60 °C	T3	338 °F	170 °C	yes	yes				
				158 °F	70 °C	T3	383 °F	195 °C	No	No				
				158 °F	70 °C	T3	302 °F	150 °C	yes	No				
				158 °F	70 °C	T4	257 °F	125 °C	yes	yes				
				F3	<b>FM</b> XP / CL I / DIV 1 / GP ABCD / T6...T1 DIP / CL II, III / DIV 1 / GP EFG / T6...T1 CL I, ZN 1 AEx d IIC T6...T1  <b>cCSAus</b> XP / CL I / DIV 1 / GP BCD / T6...T1 DIP / CL II, III / DIV 1 / GP EFG / T6...T1 Ex d IIC T6...T1 DIP A21 TA 85°C to T <sub>medium</sub>	31 / 32 <sup>4)</sup>	U <sub>max</sub> = 46 V	104 °F	40 °C	T1	824 °F	440 °C	No	No
								104 °F	40 °C	T1	707 °F	375 °C	yes	No
104 °F	40 °C	T1	500 °F					260 °C	yes	yes				
122 °F	50 °C	T1	572 °F					300 °C	yes	No				
122 °F	50 °C	T2	554 °F					290 °C	yes	No				
122 °F	50 °C	T2	428°F					220 °C	yes	yes				
41 / 42 <sup>4)</sup>	U <sub>max</sub> = 30 V I <sub>max</sub> = 30 mA P <sub>max</sub> = 115 mW	140 °F	60 °C			T2	608 °F	320 °C	No	No				
		140 °F	60 °C			T2	446 °F	230°C	yes	No				
		140 °F	60 °C			T3	338 °F	170 °C	yes	yes				
		140 °F	60 °C			T4	266 °F	130 °C	yes	yes				
		140 °F	60 °C			T5	203 °F	95 °C	yes	yes				
		140 °F	60 °C			T6	176 °F	80 °C	yes	yes				

1) Order code "Explosion protection and approvals" (versions 9, 10); refer to chapter „Ordering Information" on page 50.

2) For connection to an intrinsically safe circuit.

3) Installation in accordance with Installation Drawing SDM-10-A0253.

4) For connection to a non-intrinsically safe circuit.

Continuation of Table 4: Analog indicator with transmitter, with or without LCD indicator (temperature data for FM in °F, for cCSAus in °C)

Order code <sup>1)</sup>	Labeling	Terminals	Electrical values	T <sub>amb</sub>	T <sub>amb</sub>	Temp. class	T <sub>medium</sub>		Insulation	Heating jacket
				-58 °F ...	-50 °C ...		Maximum			
F3 <sup>5)</sup> , F4 <sup>5)</sup>	<b>FM</b> NI / CL I,II / DIV 2 / GP ABCDFG / T4...T1 NI / CL III / T4...T1 CL II, ZN 2 AEx nA [nL] IIC T4...T1  <b>cCSAus</b> NI / CL I,II / DIV 2 / GP ABCDFG / T4...T1 NI / CL III / T4...T1 Ex nA [nL] IIC T4...T1 DIP A21 TA 85°C to T <sub>medium</sub>	31 / 32 <sup>4)</sup>	U <sub>max</sub> = 46 V	104 °F	104 °F	T1	824 °F	440 °C	No	No
				104 °F	104 °F	T1	707 °F	375 °C	yes	No
				104 °F	104 °F	T1	500 °F	260 °C	yes	yes
				122 °F	122 °F	T1	572 °F	300 °C	yes	No
				122 °F	122 °F	T2	554 °F	290 °C	yes	No
				122 °F	122 °F	T2	428 °F	220 °C	yes	yes
				140 °F	140 °F	T2	608 °F	320 °C	No	No
		41 / 42 <sup>4)</sup>	U <sub>max</sub> = 30 V I <sub>max</sub> = 30 mA P <sub>max</sub> = 115 mW	140 °F	60 °C	T2	446 °F	230 °C	yes	No
				140 °F	60 °C	T3	338 °F	170 °C	yes	yes
				158 °F	70 °C	T3	383 °F	195 °C	No	No
				158 °F	70 °C	T3	302 °F	150 °C	yes	No
				158 °F	70 °C	T4	266 °F	130 °C	yes	yes
				158 °F	70 °C	T5	203 °F	95 °C	yes	yes
				86 °F	30 °C	T6	77 °F	25 °C	yes	yes

- 1) Order code "Explosion protection and approvals" (version digit No. 9, 10); refer to chapter „Ordering Information“ on page 50.
- 2) For connection to an intrinsically safe circuit.
- 3) Installation in accordance with Installation Drawing SDM-10-A0253.
- 4) For connection to a non-intrinsically safe circuit.
- 5) For connection in Division 2 or Zone 2.



# VA Master FAM540

## Metal Cone Variable Area Flowmeter

### Electrical connections

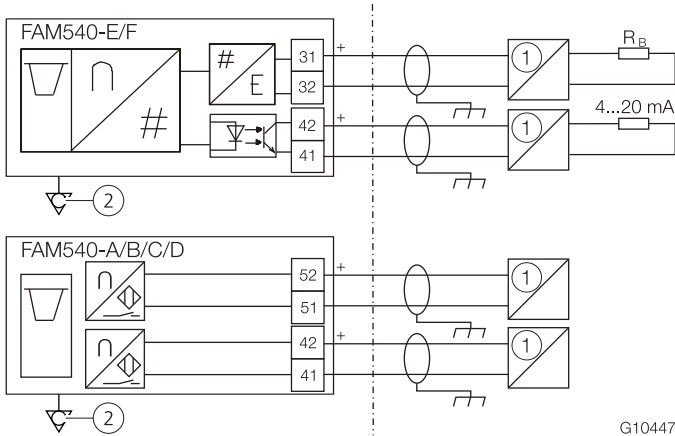

G10447

Fig. 28: FM / cCSAus electrical connection

① FM Approved IS Barrier ② Potential equalization

Terminal	Function
31 / 32	Power supply / current output / HART output
41 / 42	Binary output
	Alarm signaling unit (min.)
51 / 52	Alarm signaling unit (max.)

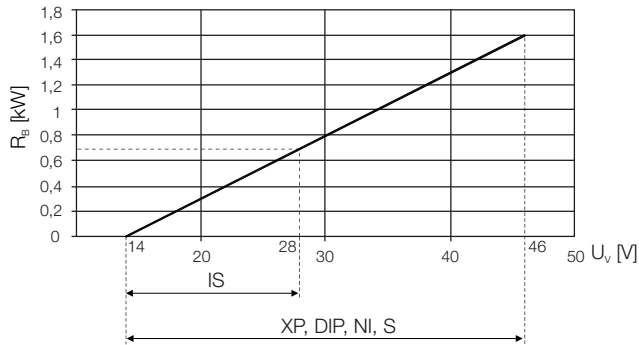

G10446

Fig. 29: Terminals 31 / 32, power supply / load

$U_V$  Power supply

$R_B$  Maximum permissible load in the power supply (z. B. indicator)

The minimum voltage  $U_V = 0$  V is based on a load of  $0 \Omega$ .

### Installation instructions

The concept of intrinsic safety enables multiple intrinsic safety devices with FM or CSA approval to be interconnected, without entity parameters being examined specifically, subject to observation of the following conditions:

- $U_o$  or  $V_{oc}$  or  $V_t \leq 0$  V max,  $I_o$  or  $I_{sc}$  or  $I_t \leq I_{max}$ ,  $C_a$  or  $C_o \geq C_i + C_{cable}$ ,  $L_a$  or  $L_o \geq L_i + L_{cable}$ ,  $P_o \leq P_i$ .
- For installation in Class II and III environments, dust-proof ignition blocks must be used.
- Devices connected to such apparatus must not use or generate rms or direct voltages in excess of 250 V.
- Installation must meet the requirements of ANSI / ISA RP 12.6 "Installation of Intrinsically Safe Systems for Hazardous (Classified) Locations" and the National Electrical Code (ANSI / NFPA 70) sections 504, 505 and CEC.
- The configuration of the associated apparatus must have Factory Mutual Research and CSA approval in accordance with the entity concept.
- Devices must be installed in compliance with the manufacturer-supplied installation drawing of the associated apparatus.
- Changes to drawings are only permitted subject to prior approval from Factory Mutual Research and CSA.
- Only shielded twisted pair cables may be used (see above).

### NOTE

For intrinsically safe installations, the FAM540 must be installed as illustrated in the "Intrinsic Safety Control Drawing SDM-10-A0253".

## Earthing

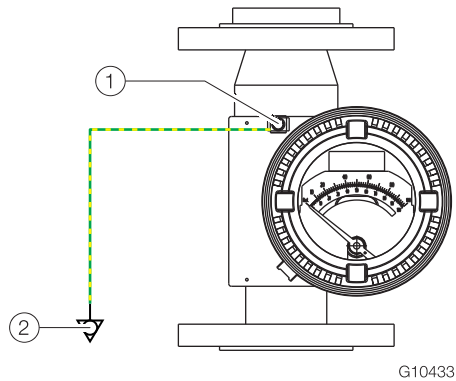

**Fig. 30: Earthing**

- ① Earthing terminal
- ② Potential equalization in accordance with EN 60079-0

The FAM540 housing must be correctly earthed in order to ensure proper function and safe operation.

Copper wires with a minimum cross-section of 6 mm<sup>2</sup> (AWG 10) must be used to connect to the potential equalization.

---

### **i** NOTE

---

The operator must ensure that when connecting the protective earth (PE), there are no potential differences between protective earth (PE) and potential equalization, even in the event of a fault.

---

## Signal cable

For ambient temperatures below 5 °C (41 °F) or above 40 °C (104 °F), signal cables that are suited for the minimum/maximum ambient temperatures in question must be used.

Only use signal cables made from copper, copper-coated aluminum, or aluminum.

The recommended tightening torque for the terminals is 0.8 Nm (7 in. lb) or higher, in accordance with the specification.

## Power supply

Installation must comply with the requirements of the National Electric Code® (ANSI / NFPA70).

Unless specified otherwise in regional or national standards, power supply lines must be dimensioned to AWG 20. Installation must be carried out as outlined in the latest edition of the manufacturer's instruction manual.

A power supply with the following requirements must be used to provide power:

- SELV (safety extra-low voltage) with LPS (current-limited source) and double or reinforced insulation.
- Maximum output current of 8 A (current-limited output).
- In accordance with National Electric Code® (ANSI / NFPA70) connected to NEC class 2.

# VA Master FAM540

## Metal Cone Variable Area Flowmeter

### Ordering Information

#### Main ordering information FAM541

##### Base model

VA Master FAM541 Metal Cone Variable Area Flowmeter, standard, for general purposes	FAM541	X	X	XX	XX	X	X	XX	X	XX
<b>Display Type / Output Signal</b>										Continued see next page
Analog indicator / Without		A								
Analog indicator / Min-Alarm (Amplifier D163A011U01 ... U03 as a separate item)		B								
Analog indicator / Max-Alarm (Amplifier D163A011U01 ... U03 as a separate item)		C								
Analog indicator / Min- and Max-Alarm (Amplifier D163A011U04 ... U06 as a separate item)		D								
Analog indicator / 4 ... 20 mA with HART protocol		E								
Analog indicator with LCD display / 4 ... 20 mA with HART protocol		F								
<b>Housing Material / Cable Gland</b>										
Aluminium / Cable gland M20 x 1.5 (Indicator type A with blind plug M25 x 1.5)			1							
Aluminium / Thread 1/2 in. NPT (Indicator type A with blind plug M25 x 1.5)			2							
Stainless steel / Cable gland M20 x 1.5 (Indicator type A with blind plug M25 x 1.5)	1)		3							
Stainless steel / Thread 1/2 in. NPT (Indicator type A with blind plug M25 x 1.5)	1)		4							
<b>Explosion Protection Certification and Approvals</b>										
Without				Y0						
ATEX / IECEx, (Zone 2 / 21), Ex nA, c, Ex tD	2)		B1							
ATEX / IECEx, (Zone 1 / 21), Ex ia, Ex nA, c, Ex tD	2)		A4							
ATEX / IECEx, (Zone 1 / 21), Ex d, Ex ia, Ex nA, c, Ex tD	3)		A9							
FM / CSA, Class I, Div 1, 2 (Zone 1, 2), XP + IS, NI	4)		F3							
FM / CSA, Class I, Div 1, 2 (Zone 1, 2), IS, NI	4)		F4							
<b>Process Connection</b>										
Flange				F1						
Flange with groove (DIN 2512)				F2						
Female thread metric (DN 25 [1 in.] = PN 100, DN 40 [1-1/2 in.] = PN 40)	5)			T1						
<b>Connection Size</b>										
DN 15 (1/2 in.)				A						
DN 25 (1 in.)				B						
DN 40 (1-1/2 in.)				N						
DN 50 (2 in.)				C						
DN 80 (3 in.)				D						
DN 100 (4 in.)				6)	E					
<b>Float Design</b>										
Standard				1						
With gas damping				7)	3					

### Main ordering information

VA Master FAM541 Metal Cone Variable Area Flowmeter, standard, for general purposes	XX	X	XX
<b>Pressure Rating</b>			
PN 16	D2		
PN 40	D4		
PN 63	9) D5		
PN 100	8) D6		
ASME CL 150	A1		
ASME CL 300	A3		
ASME CL 600	8) A6		
JIS 10K	8) J1		
<b>Design Level</b>			
(Specified by ABB)		X	
<b>Tube / Float Combination</b>			
(Specified by ABB) See flow range tables.			XX

### Additional ordering information

VA Master FAM541 Metal Cone Variable Area Flowmeter, standard, for general purposes	XX	XX	XX	XX	XX	XX
<b>Primary</b>						
Without, secondary only	10) Y0					
Standard	11) Y1					
<b>Measuring Deviation</b>						
Class 1.6 acc. VDE / VDI 3513	11) A1					
1 % of full scale	AA					
4 % of full scale (high viscosity, without calculation)	AK					
4 % of full scale (high viscosity, with calculation)	AL					
<b>Material: 3.1, 3.2 Inspection / NACE</b>						
Material monitoring with inspection certificate 3.1 acc. EN 10204			C2			
Material monitoring with inspection certificate 3.2 acc. EN 10204			C3			
Material monitoring NACE MR 01-75 with inspection certificate 3.1 acc. EN 10204			CN			
<b>Material: 2.1 Compliance</b>						
Declaration of compliance with the order 2.1 acc. EN 10204				C4		
<b>Certificates: 3.1 Visual, Dimensional and Functional Test</b>						
Inspection certificate 3.1 acc. EN 10204 of visual, dimensional and functional test					C6	
<b>Certificates: 3.1 PMI Test</b>						
Inspection certificate 3.1 acc. EN 10204 of positive material identification PMI						CA

# VA Master FAM540

## Metal Cone Variable Area Flowmeter

### Additional ordering information

VA Master FAM541 Metal Cone Variable Area Flowmeter, standard, for general purposes	XX	XX	XXX	XXX	XX	XX
<b>Certificates: 3.1 Pressure Test</b>						
Pressure test acc. AD2000	CB					
Test package (pressure test, non-destructive test, welder and welding procedure certificate) (Non-destructive test = X-ray for welding neck flanges, dye penetration test for slip-on flanges)	CP					
<b>Certificates: Calibration, Test Report</b>						
Certificate of compliance for calibration 2.1 acc. EN 10204					CM	
Inspection certificate 3.1 acc. EN 10204 of calibration, with test report					CE	
<b>Other Usage Certifications</b>						
Russia - metrological and GOST-R certificate					CG1	
Kazakhstan - metrological and GOST-K certificate (In preparation)					CG2	
Ukraine - metrological certificate					CG3	
Belarus - Metrological Certificate					CG6	
<b>Other Explosion Protection Certifications and Approvals</b>						
Russia - GOST-Ex and RTN certificate						EG7
Kazakhstan - Ex Permission certificate (In preparation)						EG3
Ukraine - GOST-Ex and Ex permission certificate (In preparation)						EG5
Belarus - GGTN Certificate						EG9
INMETRO (Brazil)						EB1
<b>Documentation Language</b>						
German						M1
English					11)	M5
Language package Western Europe / Scandinavia (Languages: DE, EN, DA, ES, FR, IT, NL, PT, FI, SV)						MW
Language package Eastern Europe (Languages: DE, EL, CS, ET, LV, LT, HU, PL, SK, SL, RO, BG)						ME
<b>Applications</b>						
Degreased for oxygen applications						P1

### Additional ordering information

VA Master FAM541 Metal Cone Variable Area Flowmeter, standard, for general purposes	XX	XX	XX	XX	XXX
<b>Device Identification Plate</b>					
Stainless steel plate with TAG no.	T0				
Adhesive label with TAG no.	11) TC				
<b>Float Material</b>					
AISI 316Ti SST (1.4571)	11)	F1			
<b>Scale Design</b>					
Direct reading scale		11)	SD		
Percentage scale			SP		
Bargraph		12)	SB		
<b>Ambient Temperature Range</b>					
Extended -40 ... 70 °C (-40 ... 158 °F) / -40 ... 60 °C (-40 ... 140 °F) with Ex protection Exd + Ex tD				13)	R5
Standard -20 ... 70 °C (-4 ... 158 °F) / -20 ... 60 °C (-4 ... 140 °F) with Ex protection Exd + Ex tD				11)	R6
<b>Alarm Relay</b>					
Amplifier Model KFA5-SR2-Ex1.W, Single Alarm, 115 V AC 50 / 60 Hz, Ambient Temperature Range -20 ... 60 °C					W11
Amplifier Model KFA6-SR2-Ex1.W, Single Alarm, 230 V AC 50 / 60 Hz, Ambient Temperature Range -20 ... 60 °C					W12
Amplifier Model KFD2-SR2-Ex1.W, Single Alarm, 24 V DC, Ambient Temperature Range -20 ... 60 °C					W13
Amplifier Model KFA5-SR2-Ex2.W, Double Alarm, 115 V AC 50 / 60 Hz, Ambient Temperature Range -20 ... 60 °C					W14
Amplifier Model KFA6-SR2-Ex2.W, Double Alarm, 230 V AC 50 / 60 Hz, Ambient Temperature Range -20 ... 60 °C					W15
Amplifier Model KFD2-SR2-Ex2.W, Double Alarm, 24 V DC, Ambient Temperature Range -20 ... 60 °C					W16

- 1) Not available with Ex d or XP applications
- 2) Version with analog indicator without output signal: Type of protection "c" only available with ATEX approval
- 3) With Ex d approved cable gland. Not available for analog indicator without output signal
- 4) Only with cable entry 1/2 in. NPT
- 5) Not available with FM / CSA approval, only available in 1 in. and 1-1/2 in. size
- 6) For liquid applications only
- 7) DN 15 ... DN 80 only (1/2 ... 3 in.)
- 8) Not available with DN 40 (1-1/2 in.) and DN 100 (4 in.)
- 9) Not available with DN 40 (1-1/2 in.)
- 10) For Ex devices upon request
- 11) Standard, automatically specified by ABB if not specified by customer
- 12) Recommended for indicator with transmitter 4 ... 20 mA with LCD display
- 13) Not available with analog indicator with alarm

# VA Master FAM540

## Metal Cone Variable Area Flowmeter

### Main ordering information FAM544

Base model		FAM544	X	X	XX	XX	X	X	XX	X	XX
VA Master FAM544 Metal Cone Variable Area Flowmeter, hygienic design, for specific food and pharmacy applications											
<b>Display Type / Output Signal</b>											
Analog indicator / Without		A									
Analog indicator / Min-Alarm (Amplifier D163A011U01 ... U03 as a separate item)		B									
Analog indicator / Max-Alarm (Amplifier D163A011U01 ... U03 as a separate item)		C									
Analog indicator / Min- and Max-Alarm (Amplifier D163A011U04 ... U06 as a separate item)		D									
Analog indicator / 4 ... 20 mA with HART protocol		E									
Analog indicator with LCD display / 4 ... 20 mA with HART protocol		F									
<b>Housing Material / Cable Gland</b>											
Aluminium / Cable gland M20 x 1.5 (Indicator type A with blind plug M25x1.5)			1								
Aluminium / Thread 1/2 in. NPT (Indicator type A with blind plug M25x1.5)			2								
Stainless steel / Cable gland M20 x 1.5 (Indicator type A with blind plug M25x1.5)		1)	3								
Stainless steel / Thread 1/2 in. NPT (Indicator type A with blind plug M25x1.5)		1)	4								
<b>Explosion Protection Certification and Approvals</b>											
Without					Y0						
ATEX / IECEx, (Zone 2 / 21), Ex nA, c, Ex tD		2)	B1								
ATEX / IECEx, (Zone 1 / 21), Ex ia, Ex nA, c, Ex tD		2)	A4								
ATEX / IECEx, (Zone 1 / 21), Ex d, Ex ia, Ex nA, c, Ex tD		3)	A9								
FM / CSA, Class I, Div 1, 2 (Zone 1, 2), XP + IS, NI		4)	F3								
FM / CSA, Class I, Div 1, 2 (Zone 1, 2), IS, NI		4)	F4								
<b>Process Connection</b>											
Thread DIN 11851					S1						
SMS 1145					S2						
<b>Connection Size</b>											
DN 25 (1 in.)					B						
DN 40 (1-1/2 in.)					N						
DN 50 (2 in.)					C						
DN 80 (3 in.)					D						
DN 100 (4 in.)					E						
<b>Float Design</b>											
Standard									1		
<b>Pressure Rating</b>											
PN 6										D0	
PN 25									5)	D3	
PN 40									6)	D4	
<b>Design Level</b>											
(Specified by ABB)											X
<b>Tube / Float Combination</b>											
(Specified by ABB.) See flow range tables.											XX

## Additional ordering information

VA Master FAM544 Metal Cone Variable Area Flowmeter, hygienic design, for specific food and pharmacy applications	XX	XX	XX	XX	XX	XX	XX	XX	XXX
<b>Primary</b>									
Without, secondary only	7)	Y0							
Standard	8)	Y1							
<b>Measuring Deviation</b>									
Class 1.6 acc. VDE / VDI 3513	8)	A1							
1 % of full scale		AA							
4 % of full scale (high viscosity, without calculation)		AK							
4 % of full scale (high viscosity, with calculation)		AL							
<b>Material: 3.1, 3.2 Inspection / NACE</b>									
Material monitoring with inspection certificate 3.1 acc. EN 10204									C2
Material monitoring with inspection certificate 3.2 acc. EN 10204									C3
Material monitoring NACE MR 01-75 with inspection certificate 3.1 acc. EN 10204									CN
<b>Material: 2.1 Compliance</b>									
Declaration of compliance with the order 2.1 acc. EN 10204									C4
<b>Certificates: 3.1 Visual, Dimensional and Functional Test</b>									
Inspection certificate 3.1 acc. EN 10204 of visual, dimensional and functional test									C6
<b>Certificates: 3.1 PMI Test</b>									
Inspection certificate 3.1 acc. EN 10204 of positive material identification PMI									CA
<b>Certificates: 3.1 Pressure Test</b>									
Pressure test acc. AD2000									CB
Test package (pressure test, non-destructive test, welder and welding procedure certificate)									CP
(Non-destructive test = X-ray for welding neck flanges, dye penetration test for slip-on flanges)									
<b>Certificates: Calibration, Test Report</b>									
Certificate of compliance for calibration 2.1 acc. EN 10204									CM
Inspection certificate 3.1 acc. EN 10204 of calibration, with test report									CE
<b>Other Usage Certifications</b>									
Russia - metrological and GOST-R certificate									CG1
Kazakhstan - metrological and GOST-K certificate (In preparation)									CG2
Ukraine - metrological certificate									CG3
Belarus - Metrological Certificate									CG6



# VA Master FAM540

## Metal Cone Variable Area Flowmeter

### Additional ordering information

VA Master FAM544 Metal Cone Variable Area Flowmeter, hygienic design, for specific food and pharmacy applications	XXX	XX	XX	XX	XX	XX	XX	XXX
<b>Other Explosion Protection Certifications and Approvals</b>								
Russia - GOST-Ex and RTN certificate	EG7							
Kazakhstan - Ex Permission certificate (In preparation)	EG3							
Ukraine - GOST-Ex and Ex permission certificate (In preparation)	EG5							
Belarus - GGTN Certificate	EG9							
INMETRO (Brazil)	EB1							
<b>Documentation Language</b>								
German		M1						
English	8)	M5						
Language package Western Europe / Scandinavia (Languages: DE, EN, DA, ES, FR, IT, NL, PT, FI, SV)		MW						
Language package Eastern Europe (Languages: DE, EL, CS, ET, LV, LT, HU, PL, SK, SL, RO, BG)		ME						
<b>Applications</b>								
Degreased for oxygen applications						P1		
<b>Device Identification Plate</b>								
Stainless steel plate with TAG no.							T0	
Adhesive label with TAG no.						8)	TC	
<b>Float Material</b>								
AISI 316Ti SST (1.4571)						8)	F1	
<b>Scale Design</b>								
Direct reading scale							8)	SD
Percentage scale								SP
Bargraph							9)	SB
<b>Ambient Temperature Range</b>								
Extended -40 ... 70 °C (-40 ... 158 °F) / -40 ... 60 °C (-40 ... 140 °F) with Ex protection Exd + Ex tD							10)	R5
Standard -20 ... 70 °C (-4 ... 158 °F) / -20 ... 60 °C (-4 ... 140 °F) with Ex protection Exd + Ex tD							8)	R6
<b>Alarm relay</b>								
Amplifier Model KFA5-SR2-Ex1.W, Single Alarm, 115 V AC 50 / 60 Hz, Ambient Temperature Range -20 ... 60 °C								W11
Amplifier Model KFA6-SR2-Ex1.W, Single Alarm, 230 V AC 50 / 60 Hz, Ambient Temperature Range -20 ... 60 °C								W12
Amplifier Model KFD2-SR2-Ex1.W, Single Alarm, 24 V DC, Ambient Temperature Range -20 ... 60 °C								W13
Amplifier Model KFA5-SR2-Ex2.W, Double Alarm, 115 V AC 50 / 60 Hz, Ambient Temperature Range -20 ... 60 °C								W14
Amplifier Model KFA6-SR2-Ex2.W, Double Alarm, 230 V AC 50 / 60 Hz, Ambient Temperature Range -20 ... 60 °C								W15
Amplifier Model KFD2-SR2-Ex2.W, Double Alarm, 24 V DC, Ambient Temperature Range -20 ... 60 °C								W16

- 1) Not available with Ex d or XP applications
- 2) Version with analog indicator without output signal: Type of protection "c" only available with ATEX approval
- 3) With Ex d approved cable gland. Not available for analog indicator without output signal
- 4) Only with cable entry 1/2 in. NPT
- 5) For DN 50 and DN 80 (2 in. and 3 in.)
- 6) For DN 25 and DN 40 (1 in. and 1-1/2 in.)
- 7) For Ex devices upon request
- 8) Standard, automatically specified by ABB if not specified by customer
- 9) Recommended for indicator with transmitter 4 ... 20 mA with LCD display
- 10) Not available with analog indicator with alarm

## Main ordering information FAM545

### Base model

VA Master FAM545 Metal Cone Variable Area Flowmeter, PTFE liner, for aggressive measuring media	FAM545	X	X	XX	XX	X	X	XX	X	XX
<b>Display Type / Output Signal</b>										
Analog indicator / Without		A								
Analog indicator / Min-Alarm (Amplifier D163A011U01 ... U03 as a separate item)		B								
Analog indicator / Max-Alarm (Amplifier D163A011U01 ... U03 as a separate item)		C								
Analog indicator / Min- and Max-Alarm (Amplifier D163A011U04 ... U06 as a separate item)		D								
Analog indicator / 4 ... 20 mA with HART protocol		E								
Analog indicator with LCD display / 4 ... 20 mA with HART protocol		F								
<b>Housing Material / Cable Gland</b>										
Aluminium / Cable gland M20 x 1.5 (Indicator type A with blind plug M25x1.5)										1
Aluminium / Thread 1/2 in. NPT (Indicator type A with blind plug M25x1.5)										2
Stainless steel / Cable gland M20 x 1.5 (Indicator type A with blind plug M25x1.5)									1)	3
Stainless steel / Thread 1/2 in. NPT (Indicator type A with blind plug M25x1.5)									1)	4
<b>Explosion Protection Certification and Approvals</b>										
Without										Y0
ATEX / IECEx, (Zone 2 / 21), Ex nA, c, Ex tD									2)	B1
ATEX / IECEx, (Zone 1 / 21), Ex ia, Ex nA, c, Ex tD									2)	A4
ATEX / IECEx, (Zone 1 / 21), Ex d, Ex ia, Ex nA, c, Ex tD									3)	A9
FM / CSA, Class I, Div 1, 2 (Zone 1, 2), XP + IS, NI									4)	F3
FM / CSA, Class I, Div 1, 2 (Zone 1, 2), IS, NI									4)	F4
<b>Process Connection</b>										
Flange										F1
<b>Connection Size</b>										
DN 25 (1 in.)										B
DN 50 (2 in.)										C
DN 80 (3 in.)										D
<b>Float Design</b>										
Standard										1
<b>Pressure Rating</b>										
PN 40										D4
ASME CL 150										A1
ASME CL 300										A3
<b>Design Level</b>										
(Specified by ABB)										X
<b>Tube / Float Combination</b>										
(Specified by ABB). See flow range tables.										XX

# VA Master FAM540

## Metal Cone Variable Area Flowmeter

### Additional ordering information

VA Master FAM545 Metal Cone Variable Area Flowmeter, PTFE liner, for aggressive measuring media	XX	XX	XX	XX	XX	XX	XX	XX	XXX	XXX
<b>Primary</b>										
Without, secondary only	5)	Y0								
Standard	6)	Y1								
<b>Measuring Deviation</b>										
Class 2.5 acc. VDE / VDI 3513	6)	A2								
4 % of full scale (high viscosity, without calculation)		AK								
<b>Material: 3.1, 3.2 Inspection / NACE</b>										
Material monitoring with inspection certificate 3.1 acc. EN 10204									C2	
Material monitoring with inspection certificate 3.2 acc. EN 10204									C3	
Material monitoring NACE MR 01-75 with inspection certificate 3.1 acc. EN 10204									CN	
<b>Material: 2.1 Compliance</b>										
Declaration of compliance with the order 2.1 acc. EN 10204									C4	
<b>Certificates: 3.1 Visual, Dimensional and Functional Test</b>										
Inspection certificate 3.1 acc. EN 10204 of visual, dimensional and functional test									C6	
<b>Certificates: 3.1 PMI Test</b>										
Inspection certificate 3.1 acc. EN 10204 of positive material identification PMI									CA	
<b>Certificates: 3.1 Pressure Test</b>										
Pressure test acc. AD2000									CB	
Test package (pressure test, non-destructive test, welder and welding procedure certificate)									CP	
(Non-destructive test = X-ray for welding neck flanges, dye penetration test for slip-on flanges)										
<b>Certificates: Calibration, Test Report</b>										
Certificate of compliance for calibration 2.1 acc. EN 10204									CM	
Inspection certificate 3.1 acc. EN 10204 of calibration, with test report									CE	
<b>Other Usage Certifications</b>										
Russia - metrological and GOST-R certificate									CG1	
Kazakhstan - metrological and GOST-K certificate (In preparation)									CG2	
Ukraine - metrological certificate									CG3	
Belarus - Metrological Certificate									CG6	
<b>Other Explosion Protection Certifications and Approvals</b>										
Russia - GOST-Ex and RTN certificate									EG7	
Kazakhstan - Ex Permission certificate (In preparation)									EG3	
Ukraine - GOST-Ex and Ex permission certificate (In preparation)									EG5	
Belarus - GGTN Certificate									EG9	
INMETRO (Brazil)									EB1	

### Additional ordering information

VA Master FAM545 Metal Cone Variable Area Flowmeter, PTFE liner, for aggressive measuring media	XX	XX	XX	XX	XX	XX	XX
<b>Documentation Language</b>							
German	M1						
English	6) M5						
Language package Western Europe / Scandinavia (Languages: DE, EN, DA, ES, FR, IT, NL, PT, FI, SV)	MW						
Language package Eastern Europe (Languages: DE, EL, CS, ET, LV, LT, HU, PL, SK, SL, RO, BG)	ME						
<b>Applications</b>							
Degreased for oxygen applications		P1					
<b>Device Identification Plate</b>							
Stainless steel plate with TAG no.					T0		
Adhesive label with TAG no.					6) TC		
<b>Float Material</b>							
PTFE						6) F2	
<b>Scale Design</b>							
Direct reading scale						6) SD	
Percentage scale						SP	
Bargraph						7) SB	
<b>Ambient Temperature Range</b>							
Extended -40 ... 70 °C (-40 ... 158 °F) / -40 ... 60 °C (-40 ... 140 °F) with Ex protection Exd + Ex tD							8) R5
Standard -20 ... 70 °C (-4 ... 158 °F) / -20 ... 60 °C (-4 ... 140 °F) with Ex protection Exd + Ex tD							6) R6
<b>Alarm relay</b>							
Amplifier Model KFA5-SR2-Ex1.W, Single Alarm, 115 V AC 50 / 60 Hz, Ambient Temperature Range -20 ... 60 °C							W11
Amplifier Model KFA6-SR2-Ex1.W, Single Alarm, 230 V AC 50 / 60 Hz, Ambient Temperature Range -20 ... 60 °C							W12
Amplifier Model KFD2-SR2-Ex1.W, Single Alarm, 24 V DC, Ambient Temperature Range -20 ... 60 °C							W13
Amplifier Model KFA5-SR2-Ex2.W, Double Alarm, 115 V AC 50 / 60 Hz, Ambient Temperature Range -20 ... 60 °C							W14
Amplifier Model KFA6-SR2-Ex2.W, Double Alarm, 230 V AC 50 / 60 Hz, Ambient Temperature Range -20 ... 60 °C							W15
Amplifier Model KFD2-SR2-Ex2.W, Double Alarm, 24 V DC, Ambient Temperature Range -20 ... 60 °C							W16

- 1) Not available with Ex d or XP applications
- 2) Version with analog indicator without output signal: Type of protection "c" only available with ATEX approval
- 3) With Ex d approved cable gland. Not available for analog indicator without output signal
- 4) Only with cable entry 1/2 in. NPT
- 5) For Ex devices upon request
- 6) Standard, automatically specified by ABB if not specified by customer
- 7) Recommended for indicator with transmitter 4 ... 20 mA with LCD display
- 8) Not available with analog indicator with alarm

# VA Master FAM540

## Metal Cone Variable Area Flowmeter

### Main ordering information FAM546

Base model										
VA Master FAM546 Metal Cone Variable Area Flowmeter, with steam jacket, for temperature-sensitive applications	FAM546	X	X	XX	XX	X	X	XX	X	XX
<b>Display Type / Output Signal</b>										Continued see next page
Analog indicator / Without	A									
Analog indicator / Min-Alarm (Amplifier D163A011U01 ... U03 as a separate item)	B									
Analog indicator / Max-Alarm (Amplifier D163A011U01 ... U03 as a separate item)	C									
Analog indicator / Min- and Max-Alarm (Amplifier D163A011U04 ... U06 as a separate item)	D									
Analog indicator / 4 ... 20 mA with HART protocol	E									
<b>Housing Material / Cable Gland</b>										
Aluminium / Cable gland M20 x 1.5 (Indicator type A with blind plug M25x1.5)										1
Aluminium / Thread 1/2 in. NPT (Indicator type A with blind plug M25x1.5)										2
Stainless steel / Cable gland M20 x 1.5 (Indicator type A with blind plug M25x1.5)										1) 3
Stainless steel / Thread 1/2 in. NPT (Indicator type A with blind plug M25x1.5)										1) 4
<b>Explosion Protection Certification and Approvals</b>										
Without										Y0
ATEX / IECEx, (Zone 2 / 21), Ex nA, c, Ex tD										2) B1
ATEX / IECEx, (Zone 1 / 21), Ex ia, Ex nA, c, Ex tD										2) A4
ATEX / IECEx, (Zone 1 / 21), Ex d, Ex ia, Ex nA, c, Ex tD										3) A9
FM / CSA, Class I, Div 1, 2 (Zone 1, 2), XP + IS, NI										4) F3
FM / CSA, Class I, Div 1, 2 (Zone 1, 2), IS, NI										4) F4
<b>Process Connection</b>										
Flange										F1
<b>Connection Size</b>										
DN 25 (1 in.)										B
DN 50 (2 in.)										C
DN 80 (3 in.)										D
DN 100 (4 in.)										E
<b>Float Design</b>										
Standard										1
With gas damping										3
<b>Pressure Rating</b>										
PN 16										D2
PN 40										D4
PN 63										D5
PN 100										D6
ASME CL 150										A1
ASME CL 300										A3
ASME CL 600										A6

## Main ordering information

VA Master FAM546 Metal Cone Variable Area Flowmeter, with steam jacket, for temperature-sensitive applications	X	XX
<b>Design Level</b> (Specified by ABB)	X	
<b>Tube / Float Combination</b> (Specified by ABB.) See flow range tables.		XX

## Additional ordering information

VA Master FAM546 Metal Cone Variable Area Flowmeter, with steam jacket, for temperature-sensitive applications	XX	XX	XX	XX	XX	XX	XX	XX	XXX
<b>Primary</b>									
Without, secondary only	5)	Y0							
Standard	6)	Y1							
<b>Measuring Deviation</b>									
Class 1.6 acc. VDE / VDI 3513	6)	A1							
1 % of full scale		AA							
4 % of full scale (high viscosity, without calculation)		AK							
4 % of full scale (high viscosity, with calculation)		AL							
<b>Material: 3.1, 3.2 Inspection / NACE</b>									
Material monitoring with inspection certificate 3.1 acc. EN 10204									C2
Material monitoring with inspection certificate 3.2 acc. EN 10204									C3
Material monitoring NACE MR 01-75 with inspection certificate 3.1 acc. EN 10204									CN
<b>Material: 2.1 Compliance</b>									
Declaration of compliance with the order 2.1 acc. EN 10204									C4
<b>Certificates: 3.1 Visual, Dimensional and Functional Test</b>									
Inspection certificate 3.1 acc. EN 10204 of visual, dimensional and functional test									C6
<b>Certificates: 3.1 PMI Test</b>									
Inspection certificate 3.1 acc. EN 10204 of positive material identification PMI									CA
<b>Certificates: 3.1 Pressure Test</b>									
Pressure test acc. AD2000									CB
Test package (pressure test, non-destructive test, welder and welding procedure certificate)									CP
(Non-destructive test = X-ray for welding neck flanges, dye penetration test for slip-on flanges)									
<b>Certificates: Calibration, Test Report</b>									
Certificate of compliance for calibration 2.1 acc. EN 10204									CM
Inspection certificate 3.1 acc. EN 10204 of calibration, with test report									CE
<b>Other Usage Certifications</b>									
Russia - metrological and GOST-R certificate									CG1
Kazakhstan - metrological and GOST-K certificate (In preparation)									CG2
Ukraine - metrological certificate									CG3
Belarus - Metrological Certificate									CG6

# VA Master FAM540

## Metal Cone Variable Area Flowmeter

### Additional ordering information

VA Master FAM546 Metal Cone Variable Area Flowmeter, with steam jacket, for temperature-sensitive applications	XXX	XX	XX	XX	XX	XX	XX	XXX
<b>Other Explosion Protection Certifications and Approvals</b>								
Russia - GOST-Ex and RTN certificate	EG7							
Kazakhstan - Ex Permission certificate (In preparation)	EG3							
Ukraine - GOST-Ex and Ex permission certificate (In preparation)	EG5							
Belarus - GGTN Certificate	EG9							
INMETRO (Brazil)	EB1							
<b>Documentation Language</b>								
German		M1						
English	6)	M5						
Language package Western Europe / Scandinavia (Languages: DE, EN, DA, ES, FR, IT, NL, PT, FI, SV)		MW						
Language package Eastern Europe (Languages: DE, EL, CS, ET, LV, LT, HU, PL, SK, SL, RO, BG)		ME						
<b>Applications</b>								
Degreased for oxygen applications						P1		
<b>Device Identification Plate</b>								
Stainless steel plate with TAG no.						T0		
Adhesive label with TAG no.					6)	TC		
<b>Float Material</b>								
AISI 316Ti SST (1.4571)						6)	F1	
<b>Scale Design</b>								
Direct reading scale						6)	SD	
Percentage scale							SP	
Bargraph						7)	SB	
<b>Ambient Temperature Range</b>								
Extended -40 ... 70 °C (-40 ... 158 °F) / -40 ... 60 °C (-40 ... 140 °F) with Ex protection Exd + Ex tD							8)	R5
Standard -20 ... 70 °C (-4 ... 158 °F) / -20 ... 60 °C (-4 ... 140 °F) with Ex protection Exd + Ex tD							6)	R6
<b>Alarm relay</b>								
Amplifier Model KFA5-SR2-Ex1.W, Single Alarm, 115 V AC 50 / 60 Hz, Ambient Temperature Range -20 ... 60 °C								W11
Amplifier Model KFA6-SR2-Ex1.W, Single Alarm, 230 V AC 50 / 60 Hz, Ambient Temperature Range -20 ... 60 °C								W12
Amplifier Model KFD2-SR2-Ex1.W, Single Alarm, 24 V DC, Ambient Temperature Range -20 ... 60 °C								W13
Amplifier Model KFA5-SR2-Ex2.W, Double Alarm, 115 V AC 50 / 60 Hz, Ambient Temperature Range -20 ... 60 °C								W14
Amplifier Model KFA6-SR2-Ex2.W, Double Alarm, 230 V AC 50 / 60 Hz, Ambient Temperature Range -20 ... 60 °C								W15
Amplifier Model KFD2-SR2-Ex2.W, Double Alarm, 24 V DC, Ambient Temperature Range -20 ... 60 °C								W16

- 1) Not available with Ex d or XP applications
- 2) Version with analog indicator without output signal: Type of protection "c" only available with ATEX approval
- 3) With Ex d approved cable gland. Not available for analog indicator without output signal
- 4) Only with cable entry 1/2 in. NPT
- 5) For Ex devices upon request
- 6) Standard, automatically specified by ABB if not specified by customer
- 7) Recommended for indicator with transmitter 4 ... 20 mA with LCD display
- 8) Not available with analog indicator with alarm

### Trademarks

® HART is a registered trademark of FieldComm Group, Austin, Texas, USA

® Buna-N is a registered trademark of DuPont Dow Elastomers.

™ Hastelloy C-2 is a Haynes International trademark

# Questionnaire







<b>Customer:</b>	<b>Date:</b>
<b>Ms./Mr.:</b>	<b>Department:</b>
<b>Telephone:</b>	<b>Fax:</b>

<b>Measuring medium:</b>	<input type="checkbox"/> _____ <input type="checkbox"/> liquid contaminated <input type="checkbox"/> Yes <input type="checkbox"/> gaseous <input type="checkbox"/> No <input type="checkbox"/> transparent Solids content <input type="checkbox"/> Yes <input type="checkbox"/> non-transparent <input type="checkbox"/> No <input type="checkbox"/> translucent Size _____
<b>Flow rate:</b>	min. _____ norm. _____ max. _____ <input type="checkbox"/> l/min <input type="checkbox"/> l/h <input type="checkbox"/> m <sup>3</sup> /min <input type="checkbox"/> m <sup>3</sup> /min <input type="checkbox"/> cm <sup>3</sup> /min <input type="checkbox"/> kg/min <input type="checkbox"/> g/min <input type="checkbox"/> kg/h <input type="checkbox"/> other _____ If a vol. gas measurement refers to standard state, (Qv)n should be added to the flow rate unit.
<b>Operating temperature:</b>	standard _____ max. _____
<b>Operating pressure:</b>	Upstream pressure (P1) _____ Downstream pressure(P1) _____ max. _____
<b>Gases:</b>	Standard density (ρn) _____ kg/m <sup>3</sup> Viscosity _____ mPa s
<b>Fluid:</b>	Concentration _____ vol. % _____ Weight % Density at operating temperature _____ kg/dm <sup>3</sup> Viscosity at operating temperature _____ mPa s
<b>Materials:</b>	Meter tube _____ Variable area _____ Gaskets _____ Other wetted parts _____
<b>Connectors:</b>	inlet <input type="checkbox"/> left <input type="checkbox"/> right <input type="checkbox"/> front <input type="checkbox"/> rear <input type="checkbox"/> from below Outlet <input type="checkbox"/> left <input type="checkbox"/> right <input type="checkbox"/> front <input type="checkbox"/> rear <input type="checkbox"/> upward <input type="checkbox"/> Thread <input type="checkbox"/> Flange <input type="checkbox"/> Hose nozzle <input type="checkbox"/> Threaded spuds in accordance with DIN 11851 other _____
<b>Installation type:</b>	<input type="checkbox"/> Cable assembly <input type="checkbox"/> Wall mounting <input type="checkbox"/> Panel mounting <input type="checkbox"/> Flush mounting
<b>Display on device:</b>	<input type="checkbox"/> % scale <input type="checkbox"/> Dk/Ds up to 1/4" size with flow rate table <input type="checkbox"/> Directly readable product scale
<b>Transmitter, electrical:</b>	<input type="checkbox"/> 0 ... 20 mA <input type="checkbox"/> 4 ... 20 mA <input type="checkbox"/> Ex <input type="checkbox"/> Non-Ex
<b>Limit switch</b>	<input type="checkbox"/> Min. contact <input type="checkbox"/> Max. contact <input type="checkbox"/> Min. and max. contact
<b>Notes:</b>	





## Our offering:

	Actuators and Positioners		Analytical Instruments
	Device Management, Fieldbus and Wireless		Flow Measurement
	Force Measurement		Level Measurement
	Natural Gas Measurement		Pressure Measurement
	Recorders and Controllers		Temperature Measurement

---

## HMI – Automação e Instrumentação, Lda.

---

Rua dos 5 Caminhos, nº 570  
4780-382 Santo Tirso  
PORTUGAL

Tel. +351 252 850 501  
Fax. +351 300 013 487

Web: [www.hmi.pt](http://www.hmi.pt)

Email: [hmi@hmi.pt](mailto:hmi@hmi.pt)



# Contact us

## **ABB Limited**

### **Process Automation**

Howard Road, St. Neots  
Cambridgeshire, PE19 8EU  
UK

Tel: +44 (0) 870 600 6122

Fax: +44 (0)1480 213 339

Mail: [enquiries.mp.uk@gb.abb.com](mailto:enquiries.mp.uk@gb.abb.com)

## **ABB Inc.**

### **Process Automation**

125 E. County Line Road  
Warminster, PA 18974  
USA

Tel: +1 215 674 6000

Fax: +1 215 674 7183

## **ABB Automation Products GmbH**

### **Process Automation**

Dransfelder Str. 2  
37079 Goettingen  
Germany

Tel: +49 551 905-0

Fax: +49 551 905-777

[www.abb.com/flow](http://www.abb.com/flow)

## Note

We reserve the right to make technical changes or modify the contents of this document without prior notice. With regard to purchase orders, the agreed particulars shall prevail. ABB does not accept any responsibility whatsoever for potential errors or possible lack of information in this document.

We reserve all rights in this document and in the subject matter and illustrations contained therein. Any reproduction, disclosure to third parties or utilization of its contents - in whole or in parts - is forbidden without prior written consent of ABB.

Copyright© 2015 ABB

All rights reserved

3KXF154001R1001



Sales



Service



Software