



FICHA TÉCNICA DE PRODUTO

PRODUCT DATASHEET

HMI – Automação e Instrumentação, Lda.

Travessa da Indústria, nº 111
4780-573 Santo Tirso
PORTUGAL

Tel. +351 252 850 501
Fax. +351 300 013 487

Web: www.hmi.pt

Email: hmi@hmi.pt

ABB MEASUREMENT & ANALYTICS | DATA SHEET

EBS862 (Contrac)

Electronic unit



For continuous control of Contrac actuators
RHD and RSD

Processor-controlled electronic unit according to the frequency converter principle

Power supply 230 V AC

Conventional signal interface (0/4 to 20 mA / 24 V)

Digital communication via RS232 and HART

Additional functions such as process controller, maintenance computer, programmable characteristics

Simple configuration and parameter setting via graphical user interface

Torque and speed variation

Reliable for short positioning times

Rack installation, IP rating IP 20

Brief description

The electronic unit builds the interface between the actuator and the control system.

During continuous positioning, the electronic unit varies the motor torque continuously until the actuator force and the control valve force are balanced. High response sensitivity and high positioning accuracy with short positioning time ensure an excellent control quality and a long actuator life.

Operating principles

The actuator continuously responds to a set point signal. The motor is permanently under voltage (operating mode S9 - 100 % stall-proof according to IEC 60034-1 / EN 60034-1) and gently increases or reduces the torque on the electronic unit in proportion to the ΔY signal (the difference between the Y set point and the Y position signal).

The actuator is not subject to temperature derating, i.e., there are no restrictions, even at the maximum permissible ambient temperature. Where a state of balance exists, the actuator force and process force are equivalent and the actuator keeps the final control element in the required position.

The classification of the 'S9 - 100 % overload protected' Contrac actuator in accordance with IEC 60034-1 / EN 60034-1 by far exceeds the requirements for the highest class, 'continuous modulation, class D' in accordance with EN 15714-2.

The Contrac actuator offers extensive process optimization capabilities thanks to its high-precision and highly dynamic operation.

Electronic unit

Electronic units are available for assembly in the field near the actuator, remotely in a mounting rack or for integrated assembly (smallest actuator type). In addition to the terminals, the electronic unit contains the microprocessor, frequency converter for motor control, analog and binary inputs and outputs, PROFIBUS® or HART® communication interfaces, the commissioning and service field and a plug connection to connect a PC.

No matter what the motor power of the respective actuator is, all electronic units are supplied single-phase by 230 V or 115 V mains supply (50 Hz or 60 Hz).

The commissioning and service field enables the end positions and direction of rotation to be set on the actuator. Moreover, status information is displayed using LEDs. Push buttons can be used to operate the actuator and set the operating mode (Automatic, Out of Service).

Analog signal and power input

For analog control, the set point entry is received from the control system through a 0 to 20 mA or 4 to 20 mA current value. Signal monitoring is possible. Should the signal leave the pre-defined limits, the actuator will perform the set safety procedure (e. g. 'Lock in last position' or 'Drive to safety position').

The position feedback is also given through a 0 to 20 mA or 4 to 20 mA feedback signal. There are 3 digital inputs and 3 digital outputs available in addition to the analog signal. If a digital input is activated, it will take priority over the set point signal (manual mode takes priority over automatic mode).

The following digital input configurations are possible:

Configuration	Digital input 1	Digital input 2	Digital input 3
OFF	No function	No function	No function
Manual intervention	Manual mode / Automatic mode	Travel command in OPEN direction	Travel command in CLOSE direction
Rapid traverse	Rapid traverse mode / Automatic mode switching	Rapid traverse travel command in OPEN direction	Rapid traverse travel command in CLOSE direction
Step controller	ON / OFF step controller activation	Step controller pulses in OPEN direction	Step controller pulses in CLOSE direction

... Brief description

... Analog signal and power input

The digital output function is freely selectable for each output. The following functions are available:

Function	Description
Ready to operate	Signaling of device status.
Signal end position 0 %	Actuator has reached the 0 % position.
Signal end position 100 %	Actuator has reached the 100 % position.
Signal limit value 1 rising	While the signal level is rising, the actuator has reached the position defined as limit value 1.
Signal limit value 1 falling	While the signal level is falling, the actuator has reached the position defined as limit value 1.
Signal limit value 2 rising	While the signal level is rising, the actuator has reached the position defined as limit value 2.
Signal limit value 2 falling	While the signal level is falling, the actuator has reached the position defined as limit value 2.
Collective failure	Drive function is no longer given. The actuator is no longer available.
Collective alarm	Parameters in the Contrac interface system have adopted values, which make a failure in the near future likely. The actuator remains functional.
Local operation	The actuator is operated via the local control station (ISF)
Rapid traverse + direction	Actuator is moving at rapid traverse speed in + direction (only for 2-motor version).
Rapid traverse control -direction	Actuator is moving at rapid traverse speed in - direction (only for 2-motor version).

Step controller operation

In the 'step controller' operating mode the incoming control commands are received as pulses at digital inputs 2 and 3 these are upward-integrated into an internal memory. The memory uses these pulses to generate an 'artificial' internal set point which the actuator then follows. This process is as easy on the control valve and actuator operation as the analog control process.

Rapid traverse mode

The actuator is operated exactly in the same operating mode as in the analog control mode. On activation of digital inputs 2 or 3, the actuator moves at twice the rated operating speed and half the torque in the corresponding direction. Just before the end position is reached, the actuator travel speed is automatically switched back to the set speed, at which the remaining distance is covered.

Speed

Contrac actuators offer different speed adjustments for both directions, independently of actuator torque or actuator force. Furthermore, a speed characteristics curve can be set with three different speed values for each direction. The actuator speed is steplessly adapted to the rate of change in speed of the set point value. This ensures a highly dynamic and extremely precise control process. In order to preserve the control valve, the actuator speed is automatically reduced before the end position is reached.

Torque/Force

The torque and actuator force setting options are comparable to the speed setting options. 50 %, 75 % and 100 % of the rated output value can be selected. The electronic unit alters the motor actuation according to the selected value.

Set point monitoring

The set point can be monitored for compliance with the adjustable limit values. Should the set point exceed the upper limit value or fall below the lower limit value, the actuator will perform the previously defined safety action. 'Lock in current Position' or 'Move to pre-defined safety position' are available as safety actions.

Ambient conditions

Temperature

Different temperature versions are available, dependent on the actuator type.

The power-up period is not subject to derating, i.e. even at the maximum permissible ambient temperature, the actuator ensures maximum control precision and dynamics during a power-up period of 100 %.

Corrosion protection

Contrac actuators and electronic units have been designed for operation in extreme ambient conditions. They satisfy the requirements of atmospheric corrosivity category C5-I (highly polluted industrial atmospheres) for protection against external corrosion in accordance with DIN EN 15714 (Electric actuators for industrial valves – Basic requirements), and EN ISO 12944-2:1998 (Paints and varnishes. Corrosion protection of steel structures by protective paint systems. Classification of environments).

Electronic cabinet modules satisfy the requirements of category C1 (low pollution) as per EN ISO 12944-2:1998 (Paints and varnishes. Corrosion protection of steel structures by protective paint systems. Classification of environments).

Maintenance interval

Contrac actuators and electronic units exceed the service life requirements for the highest class D, 'continuous modulation', as per DIN EN 15714 (Electric actuators for industrial valves – Basic requirements). The actuators remain maintenance-free for up to 10 years under 'normal' load.

Expected service life of the device

With proper use and consideration of relevant environmental conditions, the service life of the Contrac actuators and electronic units can reach approx. 10 years.

Regular maintenance work and / or proper repairs by ABB Service, along with the use of ABB spare parts, can extend the service life of the Contrac actuators and electronic units.

Communication

HART

Contrac actuators also offer the option of using the HART® communication protocol for configuration and parameterization while operation is in progress. HART®-FSK communication enables simultaneous analog set point transmission and digital communication without additional installation. The HART signal is modulated on to the 4 to 20 mA analog set point signal. The HART® protocol works with Frequency Shift Keying (FSK) technology, based on the Bell 202 communication standard.

FDI – Field Device Integration

The Device Type Driver for Contrac actuators is based on FDI technology and can either be integrated in a control system or loaded onto a PC with the ABB Ability™ Field Information Manager (FIM).

This allows you to work with the same user interface in the commissioning phase, during operation, and for service tasks involving monitoring the device, parameterization, and reading out data.

DTM

The DTM (Device Type Manager) for Contrac actuators is based on FDT / DTM technology (FDT 1.2 / 1.2.1) and can either be integrated into a control system or loaded on a PC with an FDT framework application. This allows you to work with the same user interface in the commissioning phase, during operation, and for servicing tasks, involving monitoring the device, setting parameters, and reading out data. Communication is based on HART® protocol or PROFIBUS® communication. Reading out data from the device has no effect on the operation in progress. Newly set parameters are saved in the non-volatile memory directly upon download to the device, and become active immediately.

EDD

Similar to DTM, the EDD (Electronic Device Description) provides the option of configuration and parameterization of the device through HART® communication by using a handheld terminal or an EDD integrated in the system.

Specification

General information

EBS862	
IP rating	IP 20
Humidity	≤ 75 % annual average; condensation not permitted
Rack air inlet temperature	0 to 45 °C (32 to 113 °F)
Transport and storage temperature	-25 to 70 °C (-13 to 158 °F)
Long-term storage temperature	-25 to 40 °C (-13 to 104 °F)
Mounting position	vertical, cable glands down
Vibration stress	2 to 9 Hz: maximum deflection: 3 mm (0.12 in) 9 to 200 Hz: acceleration: 1 g
Paint	2-layer component epoxy (RAL 9005, black)
Electrical connection	Mains supply via screw terminals; all other connections made via screw-type plug connectors Maximum cable length electronic unit – actuator: * 470 m at 10 mm ² (1542 ft at 8 AWG)
Weight	40 kg (88 lbs)

* The maximum cable length depends on the actuator type and cable cross-section, see 'Actuator assignment and maximum cable lengths' in the operating instruction.

Power supply

EBS862				
Supply voltage (standard actuators)	230 V AC (190 to 260 V); 47.5 to 63 Hz; single-phase			
Supply voltage (Ex actuators)	230 V AC (190 to 253 V); 47.5 to 63 Hz; single-phase			
Average power loss P_{avg} and power consumption I_{max} of the electronic unit	Actuator	P_{avg}	I_{max} at 230 V	I_{pos} (230 V): approx. 40 to 50 % of I_{max}
	RHD2500-10	80 W	5.3 A	
	RHD4000-10	100 W	10.0 A	
	RHD8000-12	115 W	8.0 A	
	RHDE8000-15	115 W	8.0 A	
	RHD16000-30	115 W	12.5 A	
	RSD50-10,0	100 W	6.4 A	
	RSD100-10,0	115 W	12.5 A	
External fuse for electronic unit	Safety fuse 35 A (Lindner) + thermal circuit breaker 16 A (ETA) (fuses are in the scope of delivery)			
External fuse for heating (dewing protection)	2 to 6 A, medium time-lag			

Communication

Conventional communication

Analog input	0 / 4 to 20 mA, internal load: 250 Ω
Analog output	0 / 4 to 20 mA, electrically isolated, maximum load: 500 Ω
3 digital inputs, 1 to 3	Digital 0: -3 to 5 V or open, electrically isolated Digital 1: 12 to 35 V, electrically isolated
3 digital outputs, 1 to 3	Potential-free relay contact, max. 60 V, 150 mA
Digital communication	RS232 for commissioning and service, optionally FSK / HART®
Default settings	See Table Conventional communication
Voltage output U_v	24 V, 15 mA, electrically isolated, for scanning external contacts, or similar applications
Connection for transmitter (optional)	Supply for two-wire transmitter with activated process controller in Contrac
Individual settings	See data sheet 10/68-2.40 or upon request

Delivery status

Conventional communication

Parameter	Setting
Function selection	Positioner, parameter: set point
Set point function	Analog set point
Set point range	4 to 20 mA
Set point characteristic	Linear; set point = position value
Actual value range	4 to 20 mA
Nominal torque / rated force in \pm direction	100 %
Automatic speed in \pm direction:	100 %
Action in 0 % / 100 % end position	Keep tight with nominal torque/rated force
Digital inputs	Digital input 1 Manual / Automatic switching, Digital input 2 / 3 Travel command \pm
Digital outputs	Digital output 1 ready for operation / error message, Digital output 2/3 end position signal 0%/100 %
Brake Away Function	Deactivated
Shut-off function	Deactivated
Positioning loop monitoring	Deactivated
Set point monitoring	Deactivated
Alarm Type	Deactivated
Action after restoration of power	Switch to Automatic
Working range of actuator	Not set

Electrical connections

Wire cross-sectional areas

EBS862 – Clamping connection	
Terminals for conductor cross-section	
Mains cable	max. 6 mm ² (10 AWG)
Signal cable (DCS)	max. 4 mm ² (12 AWG)
Transmitter (option)	max. 4 mm ² (12 AWG)
Motor cable	max. 6 mm ² (10 AWG)
Sensor cable	max. 4 mm ² (12 AWG)

Cable glands

The actuators and electronic units are supplied without cable glands. Suited cable glands must be installed on site.

Tap holes for cable glands	
	metric
Power supply	M20 × 1.5 (1 ×)
Signal cable	M20 × 1.5 (3 ×)
Motor cable	M25 × 1.5 (1 ×)

Note

The on-site cable glands for the motor and signal cables must be produced in type of protection Ex 'e' (increased safety) and must ensure contact with the cable shielding.

Selection of suited connection cables

Please observe the following information when selecting cables:

- Use shielded cables for the motor/brake cable, the sensor cable, and the signal cable to the control system/controller.
- Connect the shielding of the motor/brake cable and the sensor cable on both sides (to the actuator and to the Contrac electronic unit).

Potential equalization

In order to avoid the risk of an electric shock, it must not be possible to come into contact with dangerous live parts and conductive parts that can be touched should not become dangerous live parts either under standard conditions or under conditions when a single fault occurs.

The actual current flowing in the event of a fault is obtained from the phase to ground voltage and the total impedance present in the fault circuit.

For long cables, the voltage drop may be dangerous to come into contact with high current flowing.

Preferably, the electronic unit and the actuator must be connected with low resistance (ground resistance < 0.1 Ω) to the potential equalization.

In the process, the respective standards of the VDE 100 series must be observed.

Scenario 1

If the PE of the actuator is done only via the PE conductor of the motor cable, the maximum permissible cable lengths for the electronic units EAS822 and EBS852 are reduced in accordance with the following table.

The maximum permissible shutdown time of 200 ms in case of a fault is complied with in the process.

Max. cable length		
Conductor cross-section	EBS852	EBS862
1.5 mm ² (16 AWG)	176 m (577 ft)	48 m (157 ft)
2.5 mm ² (14 AWG)	235 m (771 ft)	79 m (259 ft)
4 mm ² (12 AWG)	460 m (1509ft)	127 m (416 ft)
6 mm ² (10 AWG)	–	190 m (623 ft)

Scenario 2

By laying an extra potential equalization conductor between the electronic unit and the actuator, with a small conductor cross-section of the motor cable (e.g. 1.5 mm²), the maximum permissible cable length can be increased.

The ground resistance of the potential equalization conductor must be < 0.1 Ω.

The maximum permissible shutdown time of 200 ms in case of a fault is complied with in the process.

Max. cable length		
Conductor cross-section	EBS852	EBS862
4 mm ² (12 AWG)	460 m (1509ft)	127 m (416 ft)
6 mm ² (10 AWG)	460 m (1509ft)	190 m (623 ft)
10 mm ² (8 AWG)	460 m (1509ft)	317 m (1040 ft)

Scenario 3

If the cable lengths specified in **General information** on page 6 are fully utilized, an additional protective potential equalization must be connected.

To do this, the electronic unit and the actuator must be connected via a short cable with a minimum cross-section of 4 mm² (12 AWG) to the on-site potential equalization.

The installation regulations for setting up grounding systems must be observed and followed.

... Electrical connections

Electronic Unit EBN862 (Contrac)

Note

The electrical connection is provided by a universal plug on the actuator and the screw terminals on the electronic unit.

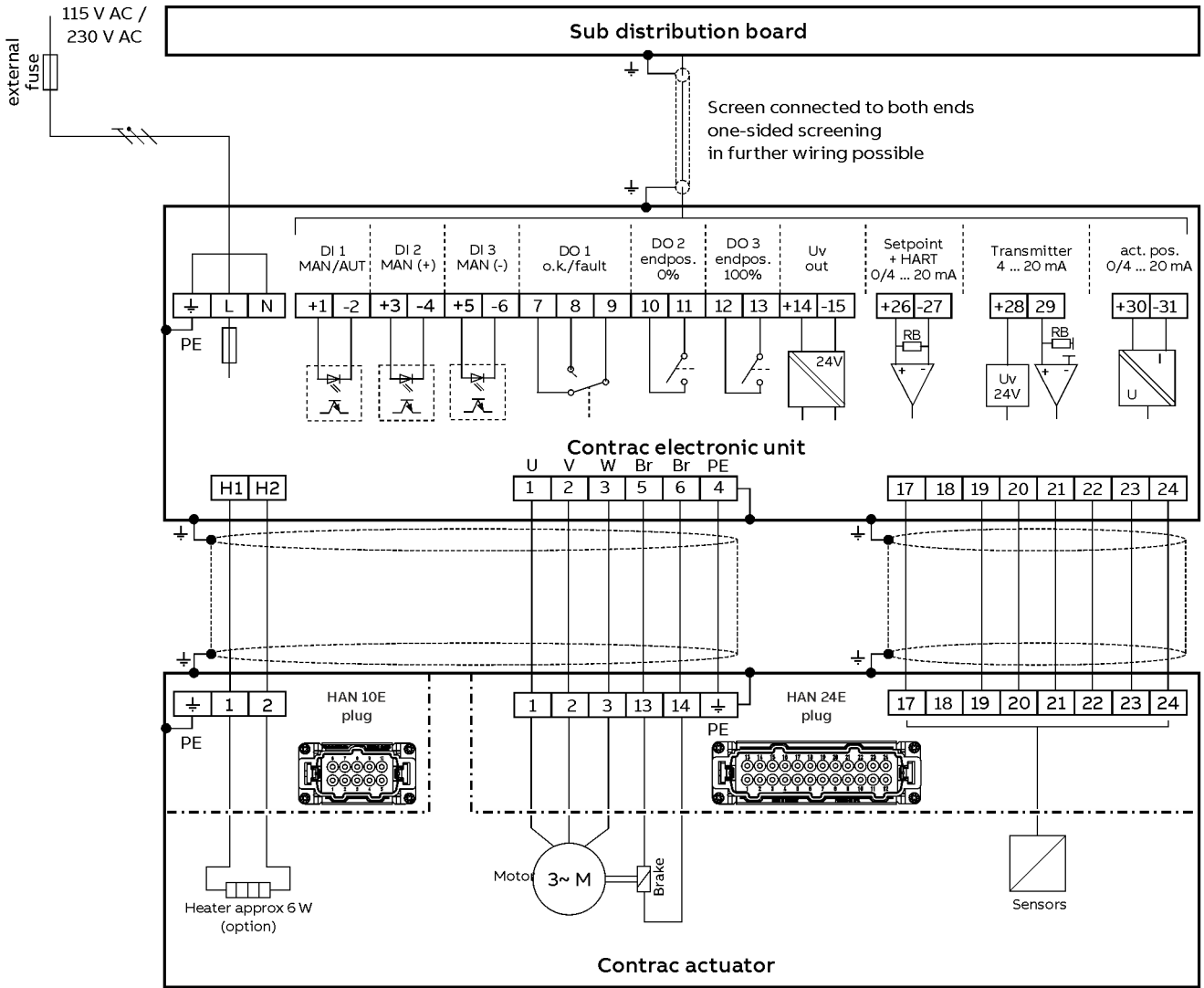

BE = digital input
 BA = digital output

Figure 1: Control via analog input 0/4 to 20 mA, HART® communication or binary inputs

Dimensions

Electronic unit

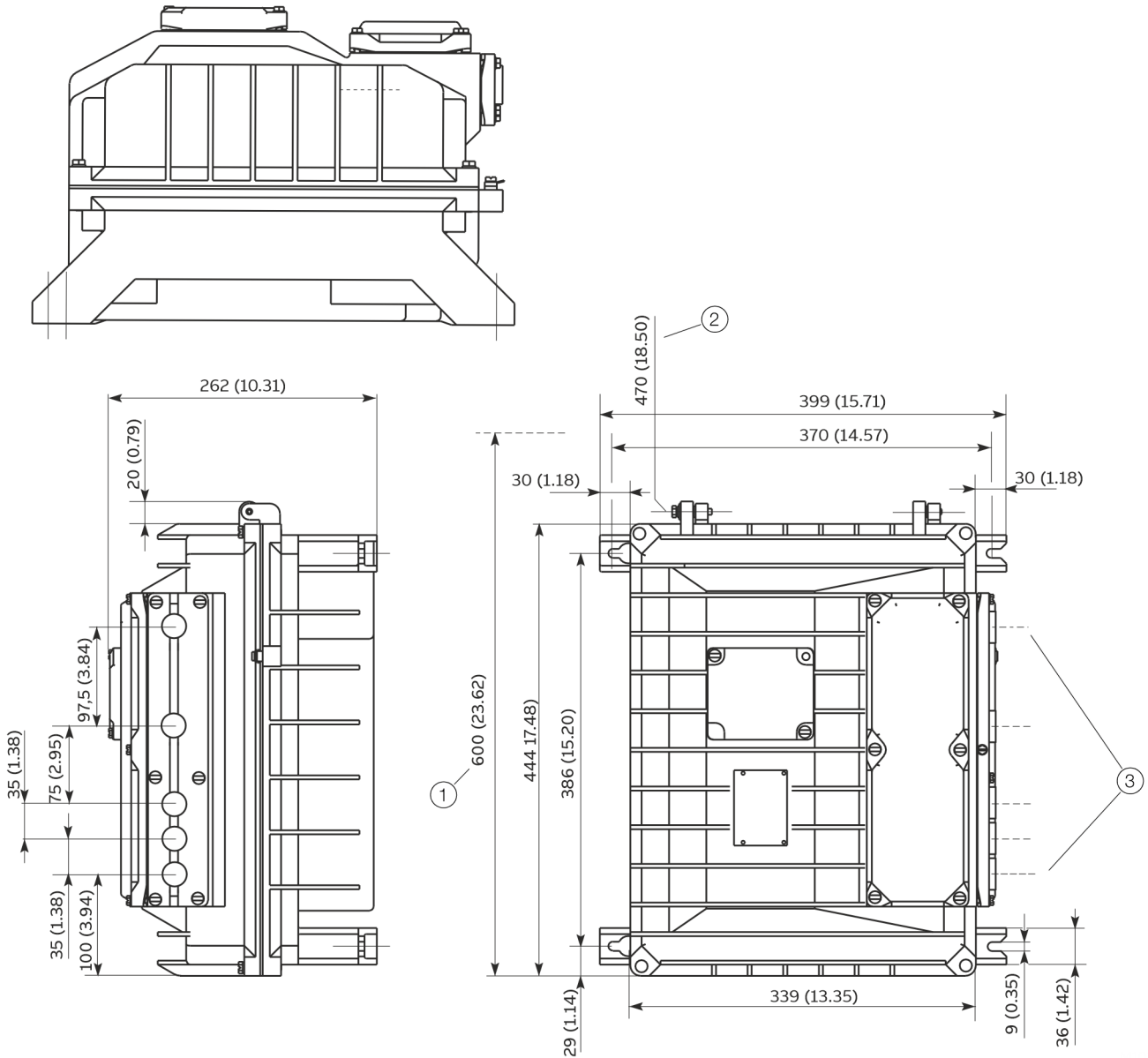

- ① Front section open, rotated 90°
- ② Rotational radius
- ③ Tap holes

Figure 2: Dimensions in mm (in)

... Dimensions

Fuses

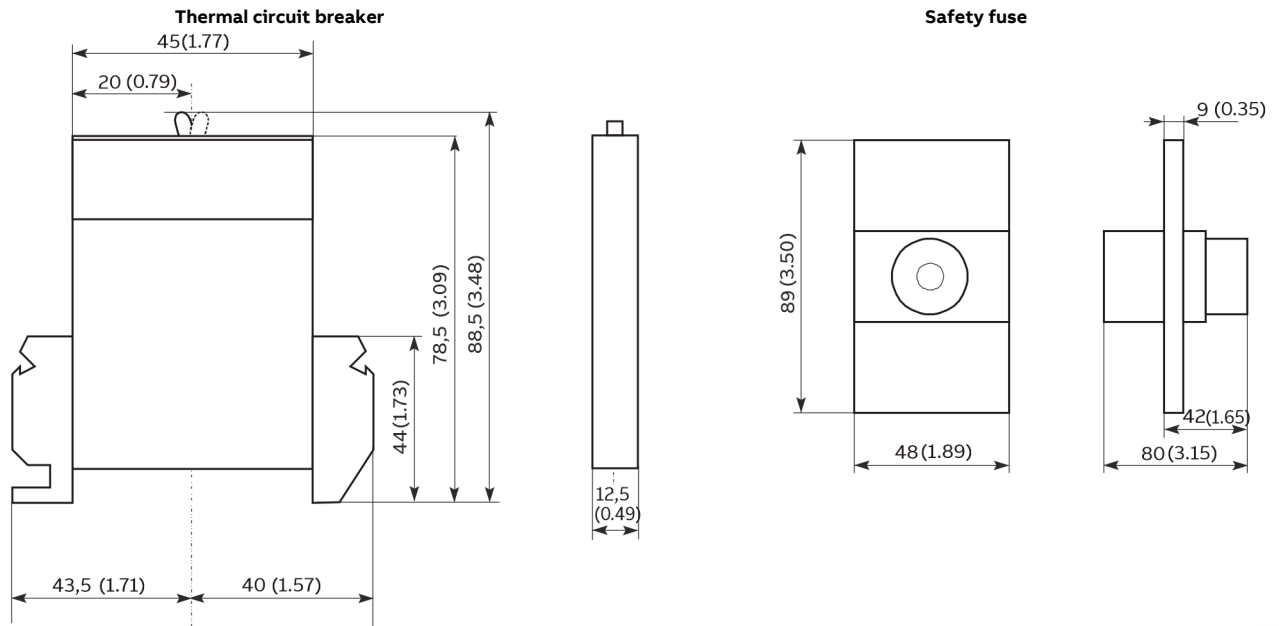

Figure 3: Dimensions in mm (in)

Ordering Information

EBS862 for Standard Actuators

Basic model	V68862A	XXXX	XXX	XXX	XXX	XXX	XXX
EBS862 Electronic Unit for Standard Actuators, for rack mounted installation							
Suitable for							
Linear Actuator RSD50-10,0/120		3073					
Linear Actuator RSD50-10,0/300		9173					
Linear Actuator RSD100-10,0/150		2174					
Linear Actuator RSD100-10,0/300		9174					
Linear Actuator RSD200-5,0/180		5475					
Linear Actuator RSD200-5,0/300		9175					
Part-Turn Actuator RHD2500-10		0115					
Part-Turn Actuator RHD4000-10		0116					
Part-Turn Actuator RHD8000-12		0170					
Part-Turn Actuator RHD16000-30		0118					
Supply Voltage							
230 V AC 1 Ph				380			
Frequency							
50 Hz					382		
60 Hz					383		
Digital Communication							
RS 232						384	
RS 232 + HART®						385	
Ambient Temperature Range of Actuator							
-30 to 50 °C (-22 to 125 °F)							341
-10 to 65 °C (15 to 150 °F)							344
Settings of Electronic Unit							
Standard settings (see technical data)							390
Customer-specific settings (see data sheet 10/68-2.40 EN)							391

... Ordering Information

... EBS862 for Standard Actuators

Additional ordering information EBS862 for Standard Actuators

EBS862 Elektronikeinheit für Standard-Antriebe, für Montage im Trägergestell	XXX	XXX	XXX	XXX	XXX	XXX	XXX	XXX	XXX
Anti-condensation Heater in Actuator "ON"									
Anti-condensation heater in actuator "ON"	359								
Identification on Data Label									
(Alphanumeric, max. 32 characters)		295							
Data Label with US Units									
Data label with US units			253						
F. No. of associated Actuator on Data Label of Electronic Unit									
F. No. of associated actuator on data label of electronic unit (Available only as "Special Requirement")				297					
Factory Certificate 2.1 acc. to EN 10204									
Factory certificate 2.1 acc. EN 10204					291				
Certificate 3.1 acc. to EN 10204									
Certificate 3.1 acc. EN 10204						292			
UKCA									
UKCA							293		
Handling of Certificates									
Send via e-mail									GHP
Send via mail									GHD
Send via mail express									GHA
Send with instrument									GHS
Only archived									GHE
Operating Instruction									
German									Z1D
English									Z1E
Portuguese									Z1P
Italian									Z1I
French									Z1F

Accessories

Description	Ordering number
RHD(E) / RSD(E) / PME / LME Save & Restore Tool ECOM700 for Contrac electronic units with software version \geq 2.0	3KXE911100L0001
RHD(E) / RSD(E) / PME / LME Save & Restore Tool ECOM688 for Contrac electronic units with software version $<$ 2.0	3201110
RHD(E) / RSD(E) / PME / LME PC connection cable, 3 m cable with 9-pole Sub-D connector and 9-pole Sub-D female connector	746349



Trademarks

HART is a registered trademark of FieldComm Group, Austin, Texas, USA

Sales



Service



ABB Measurement & Analytics

For your local ABB contact, visit:

www.abb.com/contacts

For more product information, visit:











www.abb.com/actuators

We reserve the right to make technical changes or modify the contents of this document without prior notice. With regard to purchase orders, the agreed particulars shall prevail. ABB does not accept any responsibility whatsoever for potential errors or possible lack of information in this document.

We reserve all rights in this document and in the subject matter and illustrations contained therein. Any reproduction, disclosure to third parties or utilization of its contents – in whole or in parts – is forbidden without prior written consent of ABB.



Our offering:

	Actuators and Positioners		Analytical Instruments
	Device Management, Fieldbus and Wireless		Flow Measurement
	Force Measurement		Level Measurement
	Natural Gas Measurement		Pressure Measurement
	Recorders and Controllers		Temperature Measurement

HMI – Automação e Instrumentação, Lda.

Travessa da Indústria, nº 111
4780-573 Santo Tirso
PORTUGAL

Tel. +351 252 850 501
Fax. +351 300 013 487

Web: www.hmi.pt

Email: hmi@hmi.pt