



hmi

high-accuracy
measurement
instruments

FICHA TÉCNICA DE PRODUTO

PRODUCT DATASHEET

HMI – Automação e Instrumentação, Lda.

Travessa da Indústria, nº 111
4780-573 Santo Tirso
PORTUGAL

Tel. +351 252 850 501
Fax. +351 300 013 487

Web: www.hmi.pt

Email: hmi@hmi.pt

Model 266DLH Liquid level interface transmitter

Engineered solutions for all applications

Measurement made easy



Base accuracy

— 0.10 % of calibrated span

Reliable sensing system coupled with very latest digital technologies

Specific design for low pressure

— optimize in-use total performance and stability

Flexible configuration facilities

— provided locally via local LCD keypad

New TTG (Through-The-Glass) keypad technology

— allows quick and easy local configuration without opening the cover, even in explosion proof environments

IEC 61508 certification

— version for SIL2 (1oo1) and SIL3 (1oo2) applications

PED compliance to Sound Engineering Practice (SEP)

WirelessHART version

— the battery powered solution compliant to IEC 62591

Best-in-class battery life

— up to 10 years @ 32 s update time
— in-field replaceable

Model 266DLH Liquid level interface transmitter

General description

Model 266DLH is an “application specific” transmitter using a differential design for liquid level interface and density measurements, typically for two non-mixable liquids (one upon the other) of different specific gravity, in a tank.

The transmitter has a defined structure with two seals:

- one direct mount flanged flush diaphragm seal is on the high pressure side
- one remote seal, selectable wafer or flanged flush diaphragm, is fitted via capability to the low pressure side.

The seals should have the same physical characteristics (size, materials, etc.) for the two sides; these are suitable to interface tank nozzle of 2 in. / 3in. to ASME or DN 50 / DN80 to EN.

Functional Specifications

Range and span limits

Sensor Code	Upper Range Limit (URL)	Lower Range Limit (LRL)	Minimum span	Compatibility (allowed seal) Direct mount and one remote seal (max length in m)
B	4 kPa 40 mbar 16 inH ₂ O	-4 kPa -40 mbar -16 inH ₂ O	0.4 kPa 4 mbar 1.6 inH ₂ O	3in/DN80 wafer or flanged flush diaphragm seal (2)
E	16 kPa 160 mbar 64 inH ₂ O	-16 kPa -160 mbar -64 inH ₂ O	1.6 kPa 16 mbar 6.4 inH ₂ O	2in/DN50 wafer or flanged flush diaphragm seal (2) 3in/DN80 wafer or flanged flush diaphragm seal (4)

Span limits

Maximum span = URL

IT IS RECOMMENDED TO SELECT THE TRANSMITTER SENSOR CODE PROVIDING THE TURNDOWN VALUE AS LOWEST AS POSSIBLE TO OPTIMIZE PERFORMANCE CHARACTERISTICS.

Zero suppression and elevation

Zero and span can be adjusted to any value within the range limits detailed in the table as long as:

- calibrated span \geq minimum span

Damping (feature not available for WirelessHART version)

Selectable time constant : between 0 and 60 s

This is in addition to sensor response time.

Turn on time

Operation within specification in less than 10 s with minimum damping.

Insulation resistance

> 100 M Ω at 500 V DC (terminals to earth)

Operative limits

Pressure limits:

Overpressure limits

Without damage to the transmitter

Model 266DLH	Fill fluid	Overpressure limits
Sensor B	Silicone oil	0.07 kPa abs, 0.7 mbar abs, 0.5 mmHg and 7 MPa, 70 bar, 1015 psi
Sensor E	Silicone oil	0.07 kPa abs, 0.7 mbar abs, 0.5 mmHg and 16 MPa, 160 bar, 2320 psi
Sensor B	Inert (Galden)	0.135 kPa abs, 1.35 mbar abs, 1 mmHg and 7 MPa, 70 bar, 1015 psi
Sensor E	Inert (Galden)	0.135 kPa abs, 1.35 mbar abs, 1 mmHg and 16 MPa, 160 bar, 2320 psi

Static pressure limits

Transmitters for differential pressure model 266DLH operates within specifications between the following limits:

Sensors	Static pressure limits
Sensor B	Atmosphere and 7 MPa, 70 bar, 1015 psi
Sensor E	Atmosphere and 16 MPa, 160 bar, 2320 psi

Overpressure and static upper limit can be derated by the flange rating of seal, as follows

Rating to EN 1092-1	Carbon steel flange @ 120 °C	AISI 316 ss flange @ 20 °C
PN 16	16 bar	16 bar
PN 40	40 bar	40 bar

Rating to ASME B16.5	Carbon Steel @ 100 °F (38 °C)	AISI 316 ss flange @ 100 °F (38 °C)
Class 150	285 psi	275 psi
Class 300	740 psi	720 psi

FILL FLUID CHARACTERISTICS

Fill fluid (application)	Process temperature and pressure limits				Specifications @ 25 °C (77°F)		
	Tmax @ Pabs > of	Pmin mbar abs (mmHg)	Tmax @ Pmin	Tmin	Specific gravity (kg/dm3)	Kinematic viscosity (cst)	Thermal expansion (x 10-3 /°C)
Silicone oil 5 cSt	150 (302) @ 0.7 mbar	0.7 (0.5)	100 (212)	-20 (-4)	0.91	5	1.15
Inert oil Galden G5 (oxygen service)	100 (212) @ 75 mbar	2.1 (1.52)	60 (140)	-10 (14)	1.82	4.4	1.1

Absolute viscosity (cP) = Kinematic Viscosity (cSt) x Specific gravity at specified temperature.

The absolute viscosity value is used for response time calculation.

Proof pressure

The transmitter can be exposed without leaking to line pressure of up to 28 MPa, 280 bar, 4000 psi or two times the flange rating of seal, whichever is less.

Meet ANSI/ISA-S 82.03 hydrostatic test requirements.

Temperature limits °C (°F) :

Ambient

is the operating temperature

Model 266DLH	Ambient temperature limits
Silicone oil	-20 and 85 °C (-4 and 185 °F)
Inert (Galden)	-10 and 85 °C (14 and 185 °F)

Model 266DLH	Ambient temperature limits
LCD integral display	-40 and 85 °C (-40 and 185 °F)

LCD display may not be clearly readable below -20 °C (-4 °F) or above +70 °C (+158 °F)

Models 266DLH	Ambient temperature limit
Painted AISI 316 L ss housing	max 70 °C (158 °F) continuous

IMPORTANT

For Hazardous Atmosphere applications see the temperature range specified on the certificate/approval relevant to the aimed type of protection

Storage

Models 266DLH	Storage temperature limits
Storage limits	-50 and 85 °C (-58 and 185 °F)
LCD integral display	-40 and 85 °C (-40 and 185 °F)

Process

The following table show characteristics of fill fluids for 266DLH

Model 266DLH Liquid level interface transmitter

Environmental limits

Electromagnetic compatibility (EMC)

Comply with 2014/30/UE to standards EN 61326-1:2013.
For IEC 61508 SIL certified transmitter to EN 61326-3-1:2008.
For transmitter with option "YE" to NAMUR NE 021 (2004).
Surge immunity level (with surge protector): 4 kV
(according to IEC 61000-4-5 EN 61000-4-5)

Pressure equipment directive (PED)

Comply with 2014/68/UE to standards ANSI/ISA 61010-1:2012 following Sound Engineering Practice (SEP).

Humidity

Relative humidity: up to 100 %
Condensing, icing: admissible

Vibration resistance

Accelerations up to 2 g at frequency up to 1000 Hz
(according to IEC 60068-2-6)

Shock resistance

Acceleration: 50 g
Duration: 11 ms
(according to IEC 60068-2-27)

Wet and dust-laden atmospheres

The transmitter is dust and sand tight and protected against immersion effects as defined by IEC 60529 (2001) to IP 67 (IP 68 on request) or by NEMA Type 4X.
IP65 with Harting Han connector.
Aluminium and AISI housings as barrel version also comply to IP 66 as defined by IEC 60529 (2001).

Hazardous atmospheres

(FOR ALL VERSIONS EXCEPT WirelessHART)

With or without integral display

INTRINSIC SAFETY Ex ia:

ATEX Europe (code E1) approval

II 1 G Ex ia IIC T6...T4 Ga and II 1/2 G Ex ia IIC T6...T4 Ga/Gb and

II 1 D Ex ia IIIC T85 °C Da and II 1/2 D Ex ia IIIC T85 °C Da; IP67.

IECEx (code E8) approval

Ex ia IIC T6...T4 Ga and Ex ia IIIC T85 °C Da; IP67.

NEPSI China (code EY)

Ex ia IIC T4/T5/T6 Ga, Ex ia IIC T4/T5/T6 Ga/Gb,

Ex iaD 20 T85/T100/T135, Ex iaD 20/21 T85/T100/T135.

EXPLOSION PROOF:

ATEX Europe (code E2) approval

II 1/2 G Ex db IIC T6 Ga/Gb Ta=-50 °C to +75 °C and

II 1/2 D Ex tb IIIC T85 °C Db Ta = -50 °C to +75 °C; IP67.

IECEx (code E9) approval

Ex db IIC T6 Ga/Gb Ta=-50 °C to +75 °C and

Ex tb IIIC T85 °C Db Ta = -50 °C to +75 °C; IP67.

NEPSI China (code EZ)

Ex d IIC T6 Gb, Ex tD A21 IP67 T85 °C.

INTRINSIC SAFETY Ex ic:

ATEX Europe (code E3) type examination

II 3 G Ex ic IIC T6...T4 Gc and II 3 D Ex tc IIIC T85 °C Dc; IP67.

IECEx (code ER) type examination

Ex ic IIC T6...T4 Gc and Ex tc IIIC T85 °C Dc; IP67.

NEPSI China (code ES) type examination

Ex ic IIC T4~T6 Gc, Ex nA IIC T4~T6 Gc, Ex tD A22 IP67 T85 °C.

COMBINED ATEX (code E7 = E1 + E2), (code EW = E1 + E2 + E3)

COMBINED IECEx (code EH = E8 + E9), (code EI = E8 + E9 + ER)

COMBINED NEPSI (code EP = EY + EZ), (code EQ = EY + EZ + ES)

Hazardous atmospheres

(FOR ALL VERSIONS EXCEPT WirelessHART)

With or without integral display

FM Approvals US (code E6) and FM Approvals Canada (code E4):

- Explosionproof (US): Class I, Division 1, Groups A, B, C, D; T5
- Explosionproof (Canada): Class I, Division 1, Groups B, C, D; T5
- Dust-ignitionproof: Class II, Division 1, Groups E, F, G; Class III, Div. 1; T5
- Flameproof (US): Class I, Zone 1 AEx d IIC T4 Gb
- Flameproof (Canada): Class I, Zone 1 Ex d IIC T4 Gb
- Nonincendive: Class I, Division 2, Groups A, B, C, D T6...T4
- Energy limited (US): Class I, Zone 2 AEx nC IIC T6...T4
- Energy limited (Canada): Class I, Zone 2 Ex nC IIC T6...T4
- Intrinsically safe: Class I, II, III, Division 1, Groups A, B, C, D, E, F, G T6...T4
 - Class I, Zone 0 AEx ia IIC T6...T4 (US)
 - Class I, Zone 0 Ex ia IIC T6...T4 (Canada)

Type 4X, IP67 for all above markings.

COMBINED FM Approvals US and Canada

- Intrinsically safe (code EA)
- Explosionproof, Flameproof and Dust-ignitionproof (code EB)
- Nonincendive and Energy Limited (code EC)

COMBINED ATEX, FM and IECEx Approvals (code EN = EW + E4 + E6+ E)

Technical Regulations Customs Union EAC (Russia, Kazakhstan, Belarus), Inmetro (Brazil), Kosha (Korea)

Hazardous atmospheres

(ONLY FOR WirelessHART VERSION)

With or without integral display

INTRINSIC SAFETY:

ATEX Europe (code E1) approval

II 1 G Ex ia IIC T4 and II 1/2 G Ex ia IIC T4.

IECEx (code E8) approval

Ex ia IIC T4.

FM Approvals US and FM Approvals Canada:

- Intrinsically safe: Class I, Div. 1, Groups A, B, C, D; T4 (code EA)
 - Class I, Zone 0 AEx ia IIC T4, Gb (FM US)
 - Class I, Zone 0 Ex ia IIC T4, Gb (FM Canada)

COMBINED ATEX, IECEx and FM Approvals US and Canada

(Code EF = E1 + E8 + EA)

IMPORTANT

REFER TO CERTIFICATES FOR AMBIENT TEMPERATURE RANGES RELATED TO THE DIFFERENT TEMPERATURE CLASSES.

Electrical Characteristics and Options

Optional indicators

Integrated digital display

(code LS; only with HART standard functionality)

Wide screen LCD, 128 x 64 pixel, 52.5 x 27.2 mm (2.06 x 1.07 in.) dot matrix.

Two keys for zero/span or without keypad.

User selectable application-specific visualizations.

Display may also indicate static pressure, sensor temperature and diagnostic messages.



Integral display with integral keypad

(code L1; not with HART standard functionality)

Wide screen LCD, 128 x 64 pixel,

52.5 x 27.2 mm (2.06 x 1.07 in.) dot matrix.

Multilanguage. Four keys for configuration and management of device.

Easy setup for quick commissioning.

User selectable application-specific visualizations.

Totalized and instantaneous flow indication.

Display may also indicate static pressure, sensor temperature and diagnostic messages and provides configuration facilities.



Integral display with Through-The-Glass (TTG) activated keypad (code L5; not with HART standard functionality)

As above integral display but equipped with the innovative TTG keypad allowing the activation of the configuration and management menus of the device without the need of removing the transmitter housing cover. TTG keypad is protected against accidental activations.



Optional surge protection

Up to 4kV

- voltage 1.2 μ s rise time / 50 μ s delay time to half value
- current 8 μ s rise time / 20 μ s delay time to half value

Process diagnostics (PILD)

Plugged impulse line detection (PILD) generates a warning via communication (HART, PA, FF). The device can be configured to drive the output to "Alarm current" or set a status "BAD".

Model 266DLH Liquid level interface transmitter

HART® digital communication and 4 to 20 mA output Standard and Advanced functionality

Device type: 1a07_{hex} (listed with HCF)

Power supply

The transmitter operates from 10.5 to 42 V DC with no load and is protected against reverse polarity connection (additional load allows operations over 42 V DC).

For Ex ia and other intrinsically safe approval power supply must not exceed 30 V DC. Minimum operating voltage increases to 12.3 V DC with optional surge protector

Ripple

20 mV max on a 250 Ω load as per HART specifications.

Load limitations

4 to 20 mA and HART total loop resistance :

$$R \text{ (k}\Omega\text{)} = \frac{\text{Supply voltage} - \text{min. operating voltage (V DC)}}{22 \text{ mA}}$$

A minimum of 250 Ω is required for HART communication.

Output signal

Two-wire 4 to 20 mA, user-selectable for linear or square root output, power of $\sqrt[3]{2}$ or $\sqrt[5]{2}$, square root for bidirectional flow, 22 points linearization table (i.e. for horizontal or spherical tank level measurement). HART® communication provides digital process variable superimposed on 4 to 20 mA signal, with protocol based on Bell 202 FSK standard.

HART revision 5 is the default HART output.

HART revision 7 is available on request.

Output current limits (to NAMUR NE 43 standard)

Overload condition

- Lower limit: 3.8 mA (configurable from 3.8 to 4 mA)
- Upper limit: 20.5 mA (configurable from 20 to 21 mA)

Alarm current

- Lower limit: 3.6 mA (configurable from 3.6 to 4 mA)
- Upper limit: 21 mA (configurable from 20 to 23 mA, limited to 22 mA for HART Safety; apply for electronics release 7.1.15 or later)

Factory setting: high alarm current

IEC 62591 WirelessHART® output

Device type: 1a06_{hex} (listed with HCF)

Network ID: ABB_{hex} [2747_{dec}]

Join keys: 57495245_{hex} [1464422981] 4c455353_{hex} [1279611731]
4649454c_{hex} [1179206988] 444b4559_{hex} [1145783641]

Power Supply

1x D-cell size lithium-thionyl chloride battery.

Battery life: 10 years at 32 sec. update time, 8 years at 16 sec. update time or 5 years at 8 sec. update time.

(at reference conditions of 25 ± 2 °C ambient temperature, data routed from 3 additional devices, LCD off).

THE BATTERY CAN BE REPLACED IN FIELD, ALSO IN HAZARDOUS CLASSIFIED AREA.

Output signal

IEC 62591 WirelessHART Version 7.5 (IEEE 802.15.4-2006);

Frequency band: 2.4 GHz DSSS

Update rate: user selectable from 1 sec. to 60 min.

Integrated adjustable omnidirectional antenna

– Output radio frequency: maximum 10 mW (10 dBm) EIRP

– Range: up to 300 m. (328 yds.)

Minimum distance between antenna and person is 0.2 m. (8 in.)

Telecommunications directive

Every wireless measuring device must be certified in accordance with the telecommunications directive, in this case the frequency range. This certification is country-specific.

European directives

Radio Equipment and Telecommunications Terminal Equipment Directive 99/5/EC R&TTE

ETSI EN 300 328 V1.7.1 in accordance with Article 3.2

ETSI EN 301 489-17

In Europe, use of the 2400 - 2483.5 MHz frequency band is not harmonized. Country-specific regulations must be observed.

Restrictions for Norway

Operation not permitted within a radius of 20 km around Ny-Alesund in Svalbard. For more information, see www.npt.no Norway Posts and Telecommunications site

Extra-european radio frequency licences

USA to FCC Part 15.247:2009;

Canada to IC RSS-210 and ICES-003;

Mexico; India; United Arab Emirates (UAE)

FOUNDATION Fieldbus™ output

Device type

LINK MASTER DEVICE

Link Active Scheduler (LAS) capability implemented.

Manufacturer code: 000320_{hex}

Device type code: 0007_{hex}

Power supply

The transmitter operates from 9 to 32 V DC, polarity independent, with or without surge protector.

For Ex ia approval power supply must not exceed 24 V DC (entity certification) or 17.5 V DC (FISCO certification), according to FF-816.

Current consumption

operating (quiescent): 15 mA

fault current limiting: 20 mA max.

Output signal

Physical layer in compliance to IEC 1158-2/EN 61158-2 with transmission to Manchester II modulation, at 31.25 kbit/s.

Function blocks/execution period

3 enhanced Analog Input blocks/25 ms max (each)

1 enhanced PID block/40 ms max.

1 standard Arithmetic block/25 ms

1 standard Input Selector block/25 ms

1 standard Control Selector block/25 ms

1 standard Signal Characterization block/25 ms

1 standard Integrator/Totalizer block/25 ms

Additional blocks

1 enhanced Resource block,

1 custom Pressure with calibration transducer block

1 custom Advanced Diagnostics transducer block including Plugged Input Line Detection

1 custom Local Display transducer block

Number of link objects

35

Number of VCRs

35

Output interface

FOUNDATION fieldbus digital communication protocol to standard H1, compliant to specification V. 1.7.

Transmitter failure mode

The output signal is “frozen” to the last valid value on gross transmitter failure condition, detected by self-diagnostics which also indicate a BAD conditions. If electronic failure or short circuit occur the transmitter consumption is electronically limited at a defined value (20 mA approx), for safety of the network.

Model 266DLH Liquid level interface transmitter

PROFIBUS® PA output

Device type

Pressure transmitter compliant to Profiles 3.0.1
Identification number: 3450_{hex}

Power supply

The transmitter operates from 9 to 32 V DC , polarity independent, with or without surge protector.
For Ex ia approval power supply must not exceed 17.5 V DC.
Intrinsic safety installation according to FISCO model.

Current consumption

operating (quiescent): 15 mA
fault current limiting: 20 mA max.

Output signal

Physical layer in compliance to IEC 1158–2/EN 61158–2 with transmission to Manchester II modulation, at 31.25 kbit/s.

Output interface

PROFIBUS PA communication according to Profibus DP50170 Part 2/DIN 19245 part 1–3.

Output update time

25 ms

Data blocks

3 analog input, 1 physical.

Additional blocks

1 Pressure with calibration transducer block
1 Advanced Diagnostics transducer block including Plugged Input Line Detection
1 Local Display transducer block

Transmitter failure mode

On gross transmitter failure condition, detected by self-diagnostics, the output signal can be driven to defined conditions, selectable by the user as safe, last valid or calculated value.

If electronic failure or short circuit occur the transmitter consumption is electronically limited at a defined value (20 mA approx), for safety of the network.

Performance specifications

Stated at reference condition to IEC 60770 ambient temperature of 20 °C (68 °F), relative humidity of 65 %, atmospheric pressure of 1013 hPa (1013 mbar), mounting position with vertical diaphragm and zero based range for transmitter with isolating diaphragms in AISI 316 L ss or Hastelloy and silicone oil fill and HART digital trim values equal to 4 mA and to 20 mA span end points, in linear mode. Unless otherwise specified, errors are quoted as % of span. Some performance referring to the Upper Range Limit are affected by the actual turndown (TD) as ratio between Upper Range Limit (URL) and calibrated span. IT IS RECOMMENDED TO SELECT THE TRANSMITTER SENSOR CODE PROVIDING THE TURNDOWN VALUE AS LOWEST AS POSSIBLE TO OPTIMIZE PERFORMANCE CHARACTERISTICS.

Accuracy rating

% of calibrated span, including combined effects of terminal based linearity, hysteresis and repeatability.
For fieldbus versions SPAN refer to analog input function block outscale range

Model	for TD	
266DLH	from 1:1 to 5:1	± 0.10 %
	from 5:1 to 10:1	± (0.02 x TD) %

Ambient temperature

per 20K (36°F) ambient temperature change on transmitter sensor between the limits of -20°C to $+65^{\circ}\text{C}$ (-4 to $+150^{\circ}\text{F}$) and per 20K (36°F) process temperature change on seals diaphragm between the process operating temperature limits

Model	Sensor	seal size	
266DLH	B	3 in. / DN 80	0.01 kPa, 0.1 mbar, 0.04 inH ₂ O
266DLH	E	2 in. / DN 50	0.03 kPa, 0.3 mbar, 0.12 inH ₂ O
266DLH	E	3 in. / DN 80	0.02 kPa, 0.2 mbar, 0.08 inH ₂ O

Static pressure

(zero errors can be calibrated out at line pressure)

per 1 MPa, 10 bar or 145 psi

Sensor code B

- zero error: $\pm 0.15\%$ of URL
- span error: $\pm 0.15\%$ of reading

Sensor code E

- zero error: $\pm 0.08\%$ of URL
- span error: $\pm 0.08\%$ of reading

Supply voltage

Within voltage/load specified limits the total effect is less than 0.005 % of URL per volt.

Load

Within load/voltage specified limits the total effect is negligible.

Electromagnetic field

Meets all the requirements of EN 61326 for surge immunity level (of NAMUR NE 21 on request).

Common mode interference

No effect from 100Vrms @ 50Hz, or 50 V DC

Physical Specification

(Refer to ordering information sheets for variant availability related to specific model or versions code)

Materials

Process isolating diaphragm (seals) (*)

AISI 316 L ss; Hastelloy® C-276.

Fill fluid (seals)

Silicone oil; Inert-Galden®.

Bolts and nuts

AISI 316 ss bolts and nuts Class A4–50 per ISO 3506, in compliance with NACE MR0175 Class II.

Sensor fill fluid

Silicone oil; Inert fill (Galden®).

Sensor housing

AISI 316 L ss.

Electronic housing and covers

Aluminium alloy (copper content $\leq 0.3\%$) with baked epoxy finish (colour RAL9002); AISI 316 L ss; AISI 316 L ss with two components epoxy mastic coated with acrylic epoxy finish (colour aluminium grey), with antistatic agents according to CEI EN 60079.

Covers O-ring

Buna N.

Local adjustments (zero, span and write protect)

For Standard HART version:

- Internal for zero and span (on communication board)
- External non-intrusive for zero, span and write protect in glass filled polyphenylene oxyde, removable (code R1).

For all other versions:

- External non-intrusive for zero, span and write protect in glass filled polyphenylene oxyde, removable.

Model 266DLH Liquid level interface transmitter

Plates

Transmitter nameplate: AISI 316 ss screwed to the electronics housing.

Certification plate and optional tag/calibration plate : self-adhesive attached to the electronics housing or AISI 316 ss fastened to the electronics housing with rivets or screws.

Optional wired-on customer data plate: AISI 316 ss.

Laser printing on metal or thermal printing on self-adhesive.

For AISI 316 L ss housing it is mandatory to select option I2 or I3 for plates in AISI 316 ss.

Calibration

Standard: at maximum span, zero based range, ambient temperature and pressure;

Optional: at specified range and ambient conditions.

Optional extras

Display (code Lx)

4-position (at 90°) user orientable, except "LS".

Optional plates (code Ix)

Code I2: AISI 316 ss plate with laser printed tag (up to 31 characters) and calibration details (up to 31 characters: lower and upper range values and engineering unit) fixed onto transmitter housing.

Code I1: AISI 316 ss wired-on plate with laser printed customized data (4 lines of 32 characters with 4 mm/0.16 in. height).

Surge protection (code S2)

Test Certificates (test, design, calibration, material traceability) (codes Cx and Hx)

Tag and manual language (codes Tx and Mx)

Communication connectors (code Ux)

Process connections

Flush diaphragm flanged seal (**):

2 in. or 3 in. ASME 150 or 300 RF;

DN 50 or DN 80 PN 16–40,

Wafer seal (remote only and with backup flange not supplied)

2 in. or 3 in. to ASME; DN 50 or DN 80 to EN.

Gasket seat finish

smooth (ASME or EN): 0.8µm (Ra)

serrated (ASME): 3.2 to 6.3µm (Ra)

serrated (EN 1092-1 Type B1): 3.2 to 12.5µm (Ra)

Electrical connections

Two 1/2 in. – 14 NPT or M20x1.5 threaded conduit entries, direct on housing. Only M20x1.5 for WirelessHART with one port used for antenna.

Special communication connector (option)

– HART: straight or angle Harting Han 8D connector and one plug.

– FOUNDATION Fieldbus, PROFIBUS PA: M12x1 or 7/8 in.

One certified stainless steel plug (supplied loose with thread according to housing entries) available as option.

Terminal block

HART version: three terminals for signal/external meter wiring up to 2.5 mm² (14 AWG), also connection points for test and communication purposes.

WirelessHART version: connection points for test and communication purposes; additional fast connection for external harvesting unit.

Fieldbus versions: two terminals for signal wiring (bus connection) up to 2.5 mm² (14 AWG)

Grounding

Internal and external 6 mm² (10 AWG) ground termination points are provided.

Mounting position

Transmitter can be mounted in any position.

Electronics housing may be rotated to any position. A positive stop prevents over travel.

Mass (without options)

9 kg to 12 kg approx (20 to 27 lb) according to specified seal(s) options; add 1.5 kg (3.4 lb) for AISI housing.

Add 650 g (1.5 lb) for packing.

Packing

Carton

Configuration

Transmitter with HART communication and 4 to 20 mA Standard configuration

Transmitters are factory calibrated to customer's specified range. Calibrated range and tag number are stamped on the tag plate. If a calibration range and tag data are not specified, the transmitter will be supplied with the plate left blank and configured as follows:

Engineering Unit	kPa
4 mA	Zero
20 mA	Upper Range Limit (URL)
Output	Linear
Damping	1 s
Transmitter failure mode	Upscale
Software tag (8 characters max)	Blank
Optional LCD display	PV in kPa; output in mA and in percentage on bargraph

Any or all the above configurable parameters, including Lower range-value and Upper range-value which must be the same unit of measure, can be easily changed using the HART hand-held communicator or by a PC running the configuration software with DTM for 266 models. The transmitter database is customized with specified flange type and material, O-ring and drain/vent materials and meter code option.

Custom configuration (option N6)

The following data may be specified in addition to the standard configuration parameters:

Descriptor	16 alphanumeric characters
Message	32 alphanumeric characters
Date	Day, month, year

For HART protocol available engineering units of pressure measure are :

Pa, kPa, MPa

inH₂O@4 °C, mmH₂O@4 °C, psi

inH₂O@20 °C, ftH₂O@20 °C, mmH₂O@20 °C

inHg, mmHg, Torr

g/cm², kg/cm², atm

mbar, bar

These and others are available for PROFIBUS and FOUNDATION Fieldbus.

(*) Wetted parts of the transmitter.

(**) Bolts and nuts, gasket and mating flange supplied by customer.

Transmitter with WirelessHART communication Standard configuration

Transmitters are factory calibrated to customer's specified range. Calibrated range and tag number are stamped on the tag plate. If a calibration range and tag data are not specified, the transmitter will be supplied with the plate left blank and configured as follows:

Engineering Unit	kPa
Output scale 0 %	Lower Range Limit (LRL)
Output scale 100 %	Upper Range Limit (URL)
Output	Linear
Update rate	16 s
Software tag (8 characters max)	Blank
Optional LCD display	PV in kPa; output in percentage on bargraph

Any or all the above configurable parameters, including Lower range-value and Upper range-value which must be the same unit of measure, can be easily changed using the HART hand-held communicator or by a PC running the configuration software with DTM for 266 models. The transmitter database is customized with specified flange type and material, O-ring and drain/vent materials and meter code option.

Custom configuration (option N6)

The following data may be specified in addition to the standard configuration parameters:

Descriptor	16 alphanumeric characters
Message	32 alphanumeric characters
Date	Day, month, year

Model 266DLH Liquid level interface transmitter

Transmitter with PROFIBUS PA communication

Standard configuration

Transmitters are factory calibrated to customer's specified range. Calibrated range and tag number are stamped on the tag plate. If a calibration range and tag data are not specified, the transmitter will be supplied with the plate left blank and configured as follows:

Measure Profile	Pressure
Engineering Unit	kPa
Output scale 0 %	Lower Range Limit (LRL)
Output scale 100 %	Upper Range Limit (URL)
Output	Linear
Hi-Hi Limit	Upper Range Limit (URL)
Hi Limit	Upper Range Limit (URL)
Low Limit	Lower Range Limit (LRL)
Low-Low Limit	Lower Range Limit (LRL)
Limits hysteresis	0.5 % of output scale
PV filter	0 s
Address (set by local key)	126
Tag	32 alphanumeric characters
Optional LCD display	PV in kPa; output in percentage on bargraph

Any or all the above configurable parameters, including the range values which must be the same unit of measure, can be easily changed by a PC running the configuration software with DTM for 266 models. The transmitter database is customized with specified flange type and material, O-ring and drain/vent materials and meter code option.

Custom configuration (option N6)

The following data may be specified in addition to the standard configuration parameters:

Descriptor	32 alphanumeric characters
Message	32 alphanumeric characters
Date	Day, month, year

Transmitter with FOUNDATION Fieldbus communication

Standard configuration

Transmitters are factory calibrated to customer's specified range. Calibrated range and tag number are stamped on the tag plate. If a calibration range and tag data are not specified, the transmitter will be supplied with the plate left blank and the analog input function block FB1 is configured as follows:

Measure Profile	Pressure
Engineering Unit	kPa
Output scale 0 %	Lower Range Limit (LRL)
Output scale 100 %	Upper Range Limit (URL)
Output	Linear
Hi-Hi Limit	Upper Range Limit (URL)
Hi Limit :	Upper Range Limit (URL)
Low Limit	Lower Range Limit (LRL)
Low-Low Limit	Lower Range Limit (LRL)
Limits hysteresis	0.5 % of output scale
PV filter time	0 s
Tag	32 alphanumeric characters
Optional LCD display	PV in kPa; output in percentage on bargraph

The analog input function block FB2 and FB3 are configured respectively for the sensor temperature measured in °C and for the static pressure measured in MPa.

Any or all the above configurable parameters, including the range values, can be changed using any host compliant to FOUNDATION fieldbus. The transmitter database is customized with specified flange type and material, O-ring and drain/vent materials and meter code option.

Custom configuration (option N6)

The following data may be specified in addition to the standard configuration parameters:

Descriptor	32 alphanumeric characters
Message	32 alphanumeric characters
Date	Day, month, year

MOUNTING DIMENSIONS (not for construction unless certified) – dimensions in mm. (in.)

266DLH with barrel housing

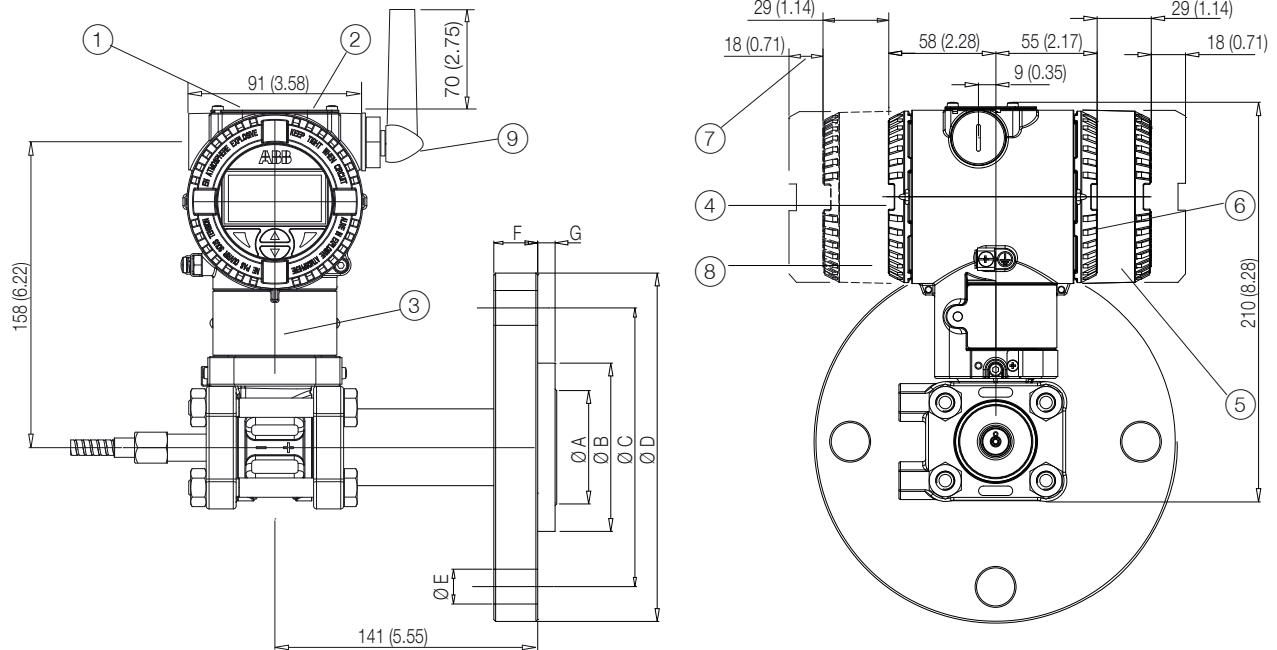

- ① Adjustments | ② Identification plate | ③ Certification plate | ④ Terminal side | ⑤ L1 and L5 integral display housing | ⑥ Electronic side | ⑦ Space for cover removal | ⑧ Battery housing of WirelessHART version | ⑨ Antenna of WirelessHART version

Wafer seal (selectable as remote on negative side)

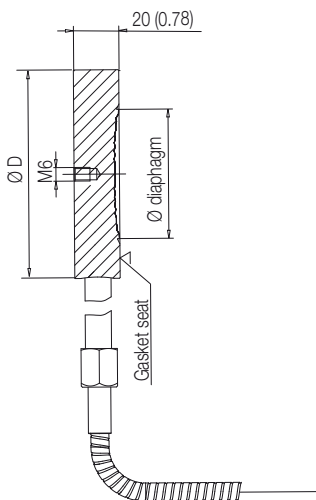

Size/Rating	Dimensions mm (in) for wafer remote seal	
	diaphragm (dia)	D (dia)
2 in. ASME B16.5	60 (2.36)	92 (3.62)
3 in. ASME B16.5	89 (3.5)	127 (5)
DN 50 EN 1092-1 Form B1	60 (2.36)	102 (4.02)
DN 80 EN 1092-1 Form B1	89 (3.5)	138 (5.43)

Model 266DLH Liquid level interface transmitter

266DLH with DIN housing

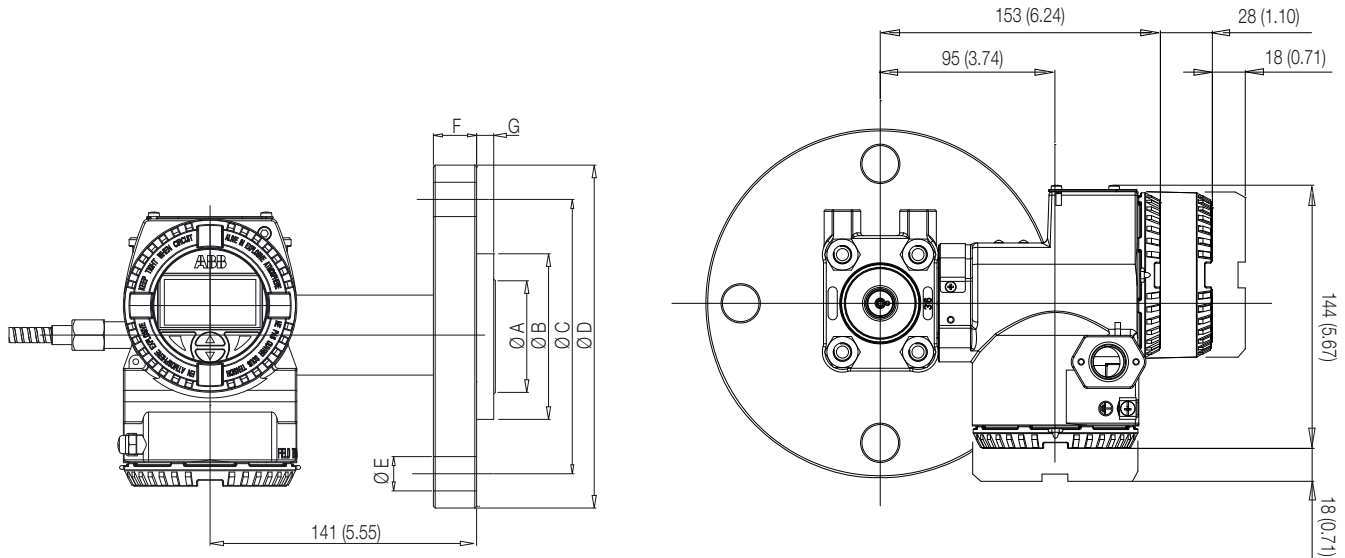

Size/Rating	Dimensions mm (in) for ASME flanged versions							
	A (dia)	B (dia)	C (dia)	D (dia)	E (dia)	F (Note 1)	G	N° of holes
2 in. ASME CL 150	60 (2.36)	92 (3.62)	120.65 (4.75)	152.4 (6)	19.1 (0.79)	17.5 (0.6)	9.5 (0.37)	4
2 in. ASME CL 300	60 (2.36)	92 (3.62)	127 (5)	165.1 (6.5)	19.1 (0.79)	20.8 (0.8)	9.5 (0.37)	8
3 in. ASME CL 150	89 (3.5)	127 (5)	152.4 (6)	190.5 (7.5)	19.1 (0.79)	22.4 (0.88)	9.5 (0.37)	4
3 in. ASME CL 300	89 (3.5)	127 (5)	168.15 (6.62)	209.6 (8.25)	22.4 (0.88)	26.9 (1.1)	9.5 (0.37)	8

Size/Rating	Dimensions mm (in) for EN flanged versions							
	A (dia)	B (dia)	C (dia)	D (dia)	E (dia)	F (Note 2)	G	N° of holes
DN 50 EN PN 16	60 (2.36)	102 (4.02)	125 (4.92)	165 (6.5)	18 (0.71)	15 (0.58)	9.5 (0.37)	4
DN 50 EN PN 40	60 (2.36)	102 (4.02)	125 (4.92)	165 (6.5)	18 (0.71)	18 (0.67)	9.5 (0.37)	4
DN 80 EN PN 16	89 (3.5)	138 (5.43)	160 (6.3)	200 (7.87)	18 (0.71)	17 (0.67)	9.5 (0.37)	8
DN 80 EN PN 40	89 (3.5)	138 (5.43)	160 (6.3)	200 (7.87)	18 (0.71)	21 (0.83)	9.5 (0.37)	8

Note 1 - Flange thickness tolerance is +3.0 / -0.0 mm (+0.12 / 0.0 in.).

Note 2 - Flange thickness tolerance is +1.0 / -1.3 mm (+0.04 / 0.05 in.) up to 18 mm or ±1.5 mm (±0.06 in.) from 18 to 50 mm from 18 to 50 mm.

Electrical connections

HART Version

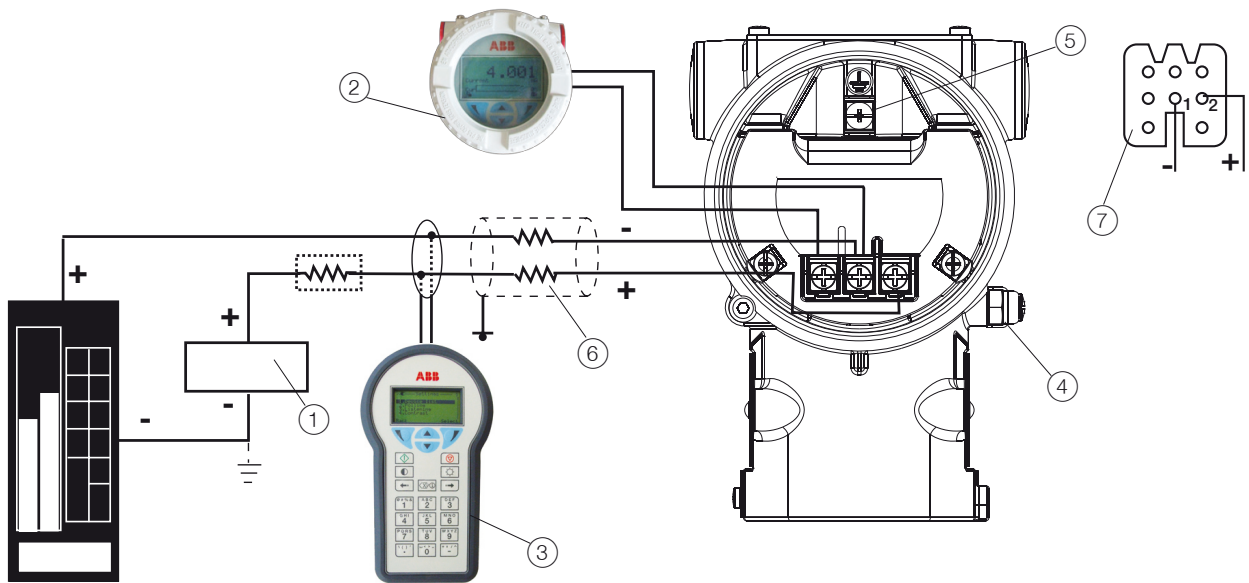

HART hand-held communicator may be connected at any wiring termination point in the loop, providing the minimum resistance is 250 ohm. If this is less than 250 ohm, additional resistance should be added to allow communications. Maximum voltage drop on external remote indicator is 0.7 V DC.

FIELDBUS Versions

7/8 in connector

M12 x 1 connector

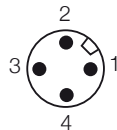
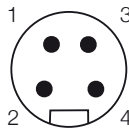

PIN (male) IDENTIFICATION		
	FOUNDATION Fieldbus	PROFIBUS PA
1	DATA -	DATA +
2	DATA +	GROUND
3	SHIELD	DATA -
4	GROUND	SHIELD

CONNECTOR IS SUPPLIED LOOSE
WITHOUT MATING FEMALE PLUG

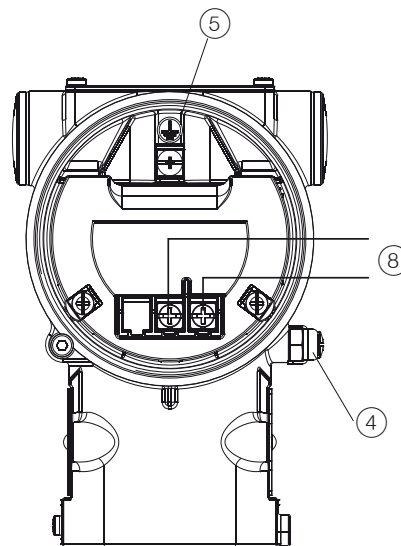

- ① Power source | ② Remote indicator | ③ Handheld communicator | ④ External ground termination point | ⑤ Internal ground termination point | ⑥ Line load | ⑦ Harting Han 8D socket insert for mating plug (supplied loose) | ⑧ Fieldbus line (polarity independent)

Model 266DLH Liquid level interface transmitter

WirelessHART version

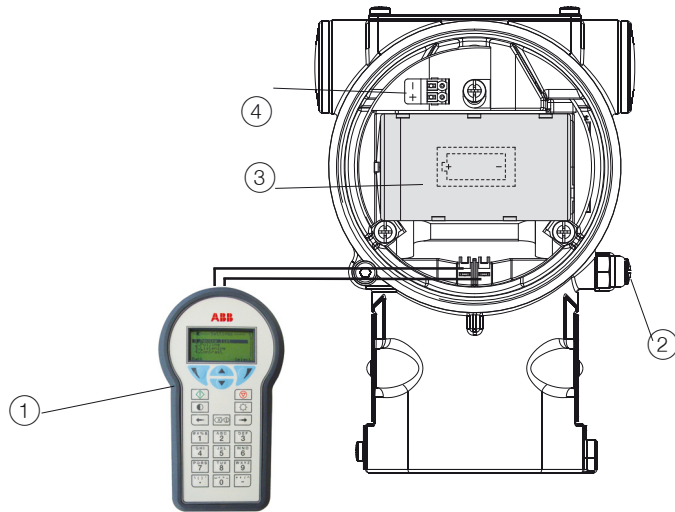

- ① Handheld communicator | ② External ground termination point | ③ Battery | ④ Fast connection for harvesting unit

Ordering information

BASIC ORDERING INFORMATION model 266DLH Differential Pressure Transmitter for liquid level interface and density

Select one character or set of characters from each category and specify complete catalog number.

Refer to additional ordering information and specify one or more codes for each transmitter if additional options are required.

BASE MODEL - 1 st to 6 th characters			2	6	D	L	H	X	X	X	X	X	X	X
Liquid level interface and density transmitter – BASE ACCURACY 0.06 %														
SENSOR - Span limits - 7 th character														
0.4 and 4 kPa	4 and 40 mbar	1.6 and 16 inH2O						B						
1.6 and 16 kPa	16 and 160 mbar	6.4 and 64 inH2O						E						
HIGH PRESSURE SIDE - Size/Mounting flange rating - 8 th character														
2 in.	ASME CL 150													
2 in.	ASME CL 300													
3 in.	ASME CL 150													
3 in.	ASME CL 300													
DN 50	EN PN 16/40													
DN 80	EN PN 16													
DN 80	EN PN 40													
HIGH PRESSURE SIDE – Mounting flange material/Seat form (seal) - 9 th character														
Carbon steel	Form RF (raised face)	(Note 1)												A
Carbon steel	EN 1092-1 Type B1	(Note 2)												G
AISI 316 ss	Form RF (raised face)	(Note 1)												D
AISI 316 ss	EN 1092-1 Type B1	(Note 2)												L

continued
see next page

Model 266DLH Liquid level interface transmitter

BASIC ORDERING INFORMATION model 266DLH DP Transmitter for liquid level interface / density				2	6	D	L	H	X	X	X	X
High and Low pressure side diaphragm material - seat finish / Fill fluid (wetted parts) (seals) - 10th character												
AISI 316 L ss - serrated finish	Silicone oil			NACE							S	
Hastelloy® C-276 - smooth finish	Silicone oil			NACE							K	
AISI 316 L ss - serrated finish	Inert fluid - Galden		(Note 3)	NACE							A	
Hastelloy® C-276 - smooth finish	Inert fluid - Galden		(Note 3)	NACE							F	
Low pressure side seal type and capillary length in m. (feet) - 11th character												
Flanged flush	0.5 (2)											1
Flanged flush	1 (3)											2
Flanged flush	1.5 (5)											3
Flanged flush	2 (7)											4
Flanged flush	2.5 (8)		(Note 4)									5
Flanged flush	3 (10)		(Note 4)									6
Flanged flush	3.5 (12)		(Note 4)									7
Flanged flush	4 (13)		(Note 4)									8
Wafer	0.5 (2)											M
Wafer	1 (3)											N
Wafer	1.5 (5)											Q
Wafer	2 (7)											S
Wafer	2.5 (8)		(Note 4)									T
Wafer	3 (10)		(Note 4)									U
Wafer	3.5 (12)		(Note 4)									V
Wafer	4 (13)		(Note 4)									Z

BASIC ORDERING INFORMATION model 266DLH DP Transmitter for liquid level interface / density				2 6 6 D L H X X X X X	X	X
Housing material and electrical connection - 12 th character						
Aluminium alloy (barrel version)	1/2 in. – 14 NPT		(Note 12)		A	
Aluminium alloy (barrel version)	M20 x 1.5 (CM 20)	(TO BE USED for WirelessHART)			B	
Aluminium alloy (barrel version)	Harting Han 8D connector	(general purpose only)	(Notes 5, 12)		E	
Aluminium alloy (barrel version)	Fieldbus connector	(general purpose only)	(Notes 5, 12)		G	
AISI 316 L ss (barrel version) (I2 or I3 required)	1/2 in. – 14 NPT		(Note 12)		S	
AISI 316 L ss (barrel version) (I2 or I3 required)	M20 x 1.5 (CM20)	(TO BE USED for WirelessHART)			T	
AISI 316 L ss (barrel version) (I2 or I3 required)	Fieldbus connector	(general purpose only)	(Notes 5, 12)		Z	
AISI 316 L ss painted (barrel version) (I2 or I3 required)	1/2 in. – 14 NPT		(Note 12)		C	
AISI 316 L ss painted (barrel version) (I2 or I3 required)	M20 x 1.5 (CM20)	(TO BE USED for WirelessHART)			D	
AISI 316 L ss painted (barrel version) (I2 or I3 required)	Fieldbus connector	(general purpose only)	(Notes 5, 12)		F	
Aluminium alloy (DIN version)	M20 x 1.5 (CM20)	(not Ex d or XP)	(Note 12)		J	
Aluminium alloy (DIN version)	Harting Han 8D connector	(general purpose only)	(Notes 5, 12)		K	
Aluminium alloy (DIN version)	Fieldbus connector	(general purpose only)	(Notes 5, 12)		W	
Output/Additional options - 13 th character						
HART and 4 to 20 mA - Standard functionality		No additional options	(Notes 6, 7)		L	
HART and 4 to 20 mA - Standard functionality		Options requested by "Additional ordering code"	(Note 6)		7	
HART and 4 to 20 mA - Advanced functionality (includes option R1)		No additional options	(Notes 6, 7)		H	
HART and 4 to 20 mA - Advanced functionality (includes option R1)		Options requested by "Additional ordering code"	(Note 6)		1	
PROFIBUS PA (includes option R1)		No additional options	(Notes 6, 7)		P	
PROFIBUS PA (includes option R1)		Options requested by "Additional ordering code"	(Note 7)		2	
FOUNDATION Fieldbus (includes option R1)		No additional options	(Notes 6, 7)		F	
FOUNDATION Fieldbus (includes option R1)		Options requested by "Additional ordering code"	(Note 7)		3	
HART and 4 to 20 mA Safety, certified to IEC 61508 (includes option R1)		No additional options	(Notes 6, 7)		T	
HART and 4 to 20 mA Safety, certified to IEC 61508 (includes option R1)		Options requested by "Additional ordering code"	(Note 6)		8	
WirelessHART (includes option R1)		No additional options	(Note 11)		W	
WirelessHART (includes option R1)		Options requested by "Additional ordering code"	(Note 11)		9	

NOTE - Option R1 represents the external pushbuttons

Model 266DLH Liquid level interface transmitter

ADDITIONAL ORDERING INFORMATION for model 266DLH

Add one or more 2-digit code(s) after the basic ordering information to select all required options

		XX
Hazardous area certifications		
ATEX Intrinsic Safety Ex ia	(Notes 6, 7)	E1
ATEX Explosion Proof Ex d	(Notes 6, 7, 8, 12)	E2
ATEX Type „N“	(Notes 6, 7, 12)	E3
Combined ATEX - Intrinsic Safety, Explosion Proof and Type „N“	(Notes 6, 7, 8, 12)	EW
Combined ATEX - Intrinsic Safety and Explosion Proof	(Notes 6, 7, 8, 12)	E7
Combined ATEX, IECEx, FM Approvals (USA) and FM Approvals (Canada)	(Notes 6, 7, 8, 12)	EN
FM Approvals (Canada) approval	(Notes 6, 7, 8, 12)	E4
FM Approvals (USA) approval	(Notes 6, 7, 8, 12)	E6
FM Approvals (USA and Canada) Intrinsically Safe	(Notes 6, 7)	EA
FM Approvals (USA and Canada) Explosion Proof, Flameproof and Dust-ignitionproof	(Notes 6, 7, 8, 12)	EB
FM Approvals (USA and Canada) Nonincendive and Energy Limited	(Notes 6, 7, 12)	EC
IECEx Intrinsic Safety Ex ia	(Notes 6, 7)	E8
IECEx Explosion Proof Ex d	(Notes 6, 7, 8, 12)	E9
IECEx Type „N“ Ex nL	(Notes 6, 7, 12)	ER
Combined IECEx - Intrinsic Safety, Explosion Proof and Type „N“	(Notes 6, 7, 8, 12)	EI
Combined IECEx - Intrinsic Safety and Explosion Proof	(Notes 6, 7, 8, 12)	EH
NEPSI Intrinsic Safety Ex ia	(Notes 6, 7, 12)	EY
NEPSI Explosion Proof Ex d	(Notes 6, 7, 8, 12)	EZ
NEPSI Type „N“	(Notes 6, 7, 12)	ES
Combined NEPSI - Intrinsic Safety, Explosion Proof and Type „N“	(Notes 6, 7, 8, 12)	EQ
Combined NEPSI - Intrinsic Safety and Explosion Proof	(Notes 6, 7, 8, 12)	EP
Combined Intrinsic Safety - ATEX, IECEx and FM Approvals (USA and Canada)	(Note 13)	EF

ADDITIONAL ORDERING INFORMATION FOR MODEL 266DLH			XX	XX	XX	XX
Other hazardous area certifications (ONLY AS ALTERNATIVE TO BASIC CERTIFICATION CODE Ex)						
Technical Regulations Customs Union (EAC) Intrinsic Safety Ex ia for Russia	(Notes 6, 7, 12)	W1				
Technical Regulations Customs Union (EAC) Explosion Proof Ex d for Russia	(Notes 6, 7, 8, 12)	W2				
Technical Regulations Customs Union (EAC) combined Ex ia and Ex d for Russia	(Notes 6, 7, 8, 12)	WC				
Technical Regulations Customs Union (EAC) Intrinsic Safety Ex ia for Kazakhstan	(Notes 6, 7, 12)	W3				
Technical Regulations Customs Union (EAC) Explosion Proof Ex d for Kazakhstan	(Notes 6, 7, 8, 12)	W4				
Technical Regulations Customs Union (EAC) combined Ex ia and Ex d for Kazakhstan	(Notes 6, 7, 8, 12)	WD				
Inmetro (Brazil) Ex ia	(Notes 6, 7, 12)	W5				
Inmetro (Brazil) Ex d	(Notes 6, 7, 8, 12)	W6				
Inmetro (Brazil) Ex nL	(Notes 6, 7, 12)	W7				
Combined Inmetro (Brazil) - Intrinsic Safety, Explosion Proof and Type „N“	(Notes 6, 7, 8, 12)	W8				
Technical Regulations Customs Union (EAC) Intrinsic Safety Ex ia for Belarus	(Notes 6, 7, 12)	WF				
Technical Regulations Customs Union (EAC) Explosion Proof Ex d for Belarus	(Notes 6, 7, 8, 12)	WG				
Technical Regulations Customs Union (EAC) combined Ex ia and Ex d for Belarus	(Notes 6, 7, 8, 12)	WH				
Kosha (Korea) Intrinsic Safety Ex ia IIC T6, IP67	(Notes 6, 7, 10, 12)	WM				
Kosha (Korea) Explosion Proof Ex d IIC T6, IP67	(Notes 6, 7, 8, 10, 12)	WN				
Combined Kosha (Korea) - Intrinsic Safety and Explosion Proof	(Notes 6, 7, 8, 10, 12)	WP				
Integral LCD						
Digital LCD integral display	(Note 10)	L1				
TTG (Through-The-Glass) digital LCD controlled display	(Note 10)	L5				
Integrated digital LCD display (ONLY SELECTABLE WITH OUTPUT CODE 7)	(Note 15)	LS				
External non intrusive Z, S and WP pushbuttons						
Transmitters with external pushbutton (ONLY SELECTABLE WITH OUTPUT CODE 7)						R1
Surge						
Surge/Transient Protector	(Note 12)					S2

Model 266DLH Liquid level interface transmitter

ADDITIONAL ORDERING INFORMATION for model 266DLH		XX	XX	XX	XX	XX	XX
Operating manual (multiple selection allowed)							
German (FOR HART, WirelessHART and PROFIBUS VERSIONS)	M1						
Italian (ONLY FOR HART VERSIONS)	M2						
Spanish (FOR HART, WirelessHART and FOUNDATION Fieldbus VERSIONS)	M3						
French (ONLY FOR HART VERSIONS)	M4						
English	M5						
Chinese (ONLY FOR HART VERSIONS)	M6						
Swedish (ONLY FOR HART VERSIONS)	M7						
Polish (ONLY FOR HART VERSIONS)	M9						
Portuguese (ONLY FOR HART VERSIONS)	MA						
Russian (ONLY FOR HART VERSIONS)	MB						
Dutch (ONLY FOR HART VERSIONS)	MD						
Danish (ONLY FOR HART VERSIONS)	MF						
Japanese (ONLY FOR HART VERSIONS)	MJ						
Romenian (ONLY FOR HART VERSIONS)	MR						
Turkish (ONLY FOR HART VERSIONS)	MT						
Plates language							
German	T1						
Italian	T2						
Spanish	T3						
French	T4						
Additional tag plate							
Supplemental wired-on stainless steel plate	I1						
Tag and certification stainless steel plates and laser printing of tag	I2						
Tag, certification and supplemental wired-on stainless steel plates and laser printing of tag	I3						
Configuration							
Standard – Pressure = inH2O/ psi at 68 °F; Temperature = deg. F	N2						
Standard – Pressure = inH2O/ psi at 39.2 °F; Temperature = deg. F	N3						
Standard – Pressure = inH2O/ psi at 20 °C; Temperature = deg. C	N4						
Standard – Pressure = inH2O/ psi at 4 °C; Temperature = deg. C	N5						
Custom	N6						
Certificates (multiple selection allowed)							
Inspection certificate EN 10204–3.1 of calibration (9-point)	C1						
Inspection certificate EN 10204–3.1 of the pressure test	C5						
Certificate of compliance with the order EN 10204–2.1 of instrument design	C6						
Printed record of configured data of transmitter	CG						
PMI test of wetted parts	CT						
Approvals							
Metrologic Pattern for Russia (NOT APPLICABLE WITH ANY HAZARDOUS AREA CERTIFICATION)	Y1						
Metrologic Pattern for Kazakhstan (NOT APPLICABLE WITH ANY HAZARDOUS AREA CERTIFICATION)	Y2						
Metrologic Pattern for Belarus (NOT APPLICABLE WITH ANY HAZARDOUS AREA CERTIFICATION)	Y4						
Chinese pattern (NOT APPLICABLE WITH ANY HAZARDOUS AREA CERTIFICATION)	Y5						
DNV approval (PENDING)	(Notes 10, 12)						YA
Approval for Custody transfer (PENDING)							YC
Conformity to NAMUR NE 021 (2004) (NOT APPLICABLE WITH SURGE PROTECTOR CODE "S2")	(Notes 10, 12, 14, 16)						YE

ADDITIONAL ORDERING INFORMATION FOR MODEL 266DLH		XX	XX	XX
Material traceability				
Certificate of compliance with the order EN 10204–2.1 of process wetted parts		H1		
Inspection certificate EN 10204–3.1 of process wetted parts		H3		
Test report EN 10204–2.2 of pressure bearing and process wetted parts		H4		
Connector				
Fieldbus 7/8 in. (Recommended for FOUNDATION Fieldbus) - (supplied loose without mating female plug)	(Notes 7, 9, 12)		U1	
Fieldbus M12x1 (Recommended for PROFIBUS PA) - (supplied loose without mating female plug)	(Notes 7, 9, 12)		U2	
Harting Han 8D – straight entry - (supplied loose)	(Notes 6, 9, 12)		U3	
Harting Han 8D – angle entry - (supplied loose)	(Notes 6, 9, 12)		U4	
Electrical connection plug				
One certified stainless steel plug (supplied loose with thread according to housing entries)				Z1

Note 1: Not available with EN mounting flange code M, N, L

Note 2: Not available with ASME mounting flange code A, D, B, E

Note 3: Suitable for presence of strong oxidizing agent

Note 4: Not available with 2 in. or DN50 seals size code A, D, M

Note 5: Select type in additional ordering code

Note 6: Not available with Housing code G, Z, W, F

Note 7: Not available with Housing code E, K

Note 8: Not available with Housing code J, K, W

Note 9: Not available with Housing code A, B, S, T, J

Note 10: Not available with Output code 7

Note 11: Not available with Housing code A, E, G, S, Z, C, F, J, K, W

Note 12: Not available with Output code 9

Note 13: Not available with Output code 1, 2, 3, 7, 8

Note 14: Not available with Output code 2, 3

Note 15: Not available with Hazardous area certification code EY, EZ, ES, EQ, EP, W1, W2, WC, W3, W4, WD, W5, W6, W7, W8, WF, WG, WH, WM, WN, WP

Note 16: Not available with Hazardous area certification code EW, EN, E4, E6, EA, EB, EC, EY, EZ, ES, EQ, EP, W1, W2, WC, W3, W4, WD, W5, W6, W7, W8, WF, WG, WH, WM, WN, WP

Standard delivery items (can be differently specified by additional ordering code)

- General purpose (no electrical certification)
- No display, no surge protection
- Multilanguage short-form operating instruction manual and labels in english (metal nameplate; self-adhesive certification and tag)
- Configuration with kPa and deg. C units
- No test, inspection or material traceability certificates

IMPORTANT REMARK FOR ALL MODELS

THE SELECTION OF SUITABLE WETTED PARTS AND FILLING FLUID FOR COMPATIBILITY WITH THE PROCESS MEDIA IS A CUSTOMER'S RESPONSIBILITY, IF NOT OTHERWISE NOTIFIED BEFORE MANUFACTURING.

NACE COMPLIANCE INFORMATION

- (1) The materials of constructions comply with metallurgical recommendations of NACE MR0175/ISO 15156 for sour oil field production environments. As specific environmental limits may apply to certain materials, please consult latest standard for further details. AISI 316/316 L, Hastelloy C-276, Monel 400 also conform to NACE MR0103 for sour refining environments.
- (2) NACE MR0175 addresses bolting requirements in two classes:
 - Exposed bolts: bolts directly exposed to the sour environment or buried, encapsulated or anyway not exposed to atmosphere
 - Non exposed bolts: the bolting must not be directly exposed to sour environments and must be directly exposed to the atmosphere at all times.

© Hastelloy is a registered trademark of Haynes International

© Galden is a registered trademark of Solvay Group

© HART and WirelessHART are registered trademarks of HART Communication Foundation

© PROFIBUS is a registered trademark of Profibus International

™ FOUNDATION Fieldbus is a trademark of Fieldbus Foundation

Contact us

ABB Ltd.

Industrial Automation

Howard Road
St. Neots
Cambridgeshire PE19 8EU
UK
Tel: +44 (0)1480 475321
Fax: +44 (0)1480 217948

ABB Inc.

Industrial Automation

125 E. County Line Road
Warminster
PA 18974
USA
Tel: +1 215 674 6000
Fax: +1 215 674 7183

ABB Automation Products GmbH

Industrial Automation

Schillerstr. 72
32425 Minden
Germany
Tel: +49 551 905 534
Fax: +49 551 905 555

ABB S.p.A.

Industrial Automation

Via Luigi Vaccani 4
22016 Tremezzina (CO)
Italy
Tel: +39 0344 58111

www.abb.com

Note

We reserve the right to make technical changes or modify the contents of this document without prior notice. With regard to purchase orders, the agreed particulars shall prevail. ABB does not accept any responsibility whatsoever for potential errors or possible lack of information in this document.

We reserve all rights in this document and in the subject matter and illustrations contained therein. Any reproduction, disclosure to third parties or utilization of its contents - in whole or in parts - is forbidden without prior written consent of ABB.

Copyright© 2017 ABB

All rights reserved
3KXP300008R1001



Sales













Service



Software



Our offering:

	Actuators and Positioners		Analytical Instruments
	Device Management, Fieldbus and Wireless		Flow Measurement
	Force Measurement		Level Measurement
	Natural Gas Measurement		Pressure Measurement
	Recorders and Controllers		Temperature Measurement

HMI – Automação e Instrumentação, Lda.

Travessa da Indústria, nº 111
4780-573 Santo Tirso
PORTUGAL

Tel. +351 252 850 501
Fax. +351 300 013 487

Web: www.hmi.pt

Email: hmi@hmi.pt