



FICHA TÉCNICA DE PRODUTO

PRODUCT DATASHEET

---

HMI – Automação e Instrumentação, Lda.

---

Rua dos 5 Caminhos, nº 570  
4780-382 Santo Tirso  
PORTUGAL

Tel. +351 252 850 501  
Fax. +351 300 013 487

Web: [www.hmi.pt](http://www.hmi.pt)

Email: [hmi@hmi.pt](mailto:hmi@hmi.pt)

ABB MEASUREMENT & ANALYTICS | DATA SHEET

# Navigator 500

## Sodium analyzer



---

## Measurement made easy

Accurate and reliable measurement of sodium in high purity water

---

### Multi-stream measurement capability

- measure up to 3 different sample streams using a single analyzer

---

### Wide measuring range

- covers all power plant applications

---

### Automatic calibration

- minimizes manual intervention and ensures measurement accuracy

---

### Automatic electrode regeneration

- ensures electrode sensitivity when measuring trace sodium levels

---

### 'Pumpless' liquid handling section

- reduces maintenance requirements and cost-of-ownership

---

### Comprehensive diagnostics

- provides sensor condition and analyzer status data

---

### Grab sample facility

- enables unattended analysis of manually collected samples

---

### Connect multiple wet-sections to a single transmitter

- reduces footprint and installation costs

## The Navigator 500 range

The Navigator 500 range of analyzers from ABB are designed for high purity water treatment applications and power cycle chemistry monitoring.

The analysis and signal conditioning is conducted within the Navigator 550's advanced wet-section that houses the sensing technology. The accurate measurement result is transmitted digitally to the Navigator 540 transmitter.

The Navigator 540 universal transmitter enables connection of up to 4 different Navigator 550 wet-sections and is available with optional features such as SD card data retrieval and graphical trending, as well as additional outputs and communication options.

The following parameters are available in the Navigator 500 range:

### Navigator 500

- Dissolved Oxygen
- Sodium
- Hydrazine

### Navigator 500 sodium

The Navigator 500 sodium provides continuous monitoring and control of power station boiler feed water / steam condensate.

The wet-section houses ABB's specially formulated sodium ion responsive electrode and reference electrode that accurately measure the concentration of sodium ions in the water. Up to 3 different sample streams can be measured using a single Navigator 550 sodium wet-section.

Measurement results are updated digitally to the Navigator 540 transmitter where process trends of up to 4 separate wet-sections can be viewed locally on the color display. Users of this system also benefit from the Navigator 500 sodium's low maintenance requirements, ease-of-use, auto-calibration, auto electrode regeneration and proven sensing performance.

Process data, together with the content of alarm and audit logs within the transmitter, can be saved to a removable SD card for record keeping and analysis using ABB's DataManager Pro data analysis software.

### Navigator 500 transmitter



Sodium  
Hydrazine  
Dissolved Oxygen

### Navigator 550 wet-sections



Sodium

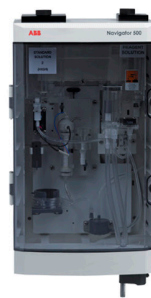

Hydrazine



Dissolved Oxygen

Figure 1 Navigator 500 family

## Applications

Typical applications for the Navigator 500 sodium analyzer include:

### Monitoring water treatment plant efficiency and quality

- Sodium measurement, at the outlet of cation and mixed resin exchange beds, provides an early indication of resin exhaustion and treated water quality.

### Condensate monitoring at the extraction pump discharge

- As condensers are operated under vacuum, leaks result in the ingress of cooling water into the process water. If the cooling water contains relatively high levels of sodium (as is usually the case), monitoring the sodium content of the process water can provide an early indication of condenser leaks.

### Saturated steam in drum boilers

- The monitoring of sodium in the saturated steam between the boiler drum and the superheater detects carryover and, in conjunction with sodium monitoring in the condensate (the sodium balance), can indicate problems caused by sodium deposits on superheated tubes and turbine blades.

### Once-through boilers

- Boiler water purity is more stringent in these boilers therefore monitoring sodium levels after the condensate polishing plant, boiler feed and superheated steam, can assist in maintaining water/steam purity within limits.

## Sodium monitoring in the water & steam cycle of power plants

### The need for accurate monitoring

Sodium is one of the most important parameters to measure in power plant applications and is the cause of many different types of boiler corrosion.

A challenge for power plant operators is that most sodium compounds are water soluble, presenting problems not only in the boiler, but also in the steam supply through carryover.

A particular problem is the formation of sodium hydroxide (NaOH). Sodium hydroxide is formed when concentrations of sodium carbonate used in the feedwater treatment process increase in the boiler as the water evaporates. As it builds up, the sodium carbonate undergoes hydrolysis, forming sodium hydroxide that attacks the iron in the boiler. As the iron dissolves, sodium ferrous is formed. This also undergoes hydrolysis, effectively regenerating the sodium hydroxide levels in the boiler.

The resulting effect of this cycle is the embrittlement of boiler components, including rivets, bends and joints where stresses are greatest.

Further problems are caused where sodium hydroxide is carried over into steam. As the steam condenses, the sodium hydroxide can accumulate in critical components, including the steam turbine, where it can attack the turbine blades.

### The Navigator 500 solution

The Navigator 500 sodium provides a continuous measurement of the sodium ion concentration in demineralization plants and in the steam / water cycle of steam-raising plants.

The wide measuring range of the ABB high performance sodium electrode and the choice of reagents available make the Navigator 500 sodium analyzer suitable for all power plant applications. A fully automatic sensor regeneration system is available for ultra low sodium measurement applications to ensure sensor sensitivity.

In the multiple stream version, up to 3 different sampling points can be measured by a single wet-section, with the measurement results sent digitally to the transmitter. Manually collected samples can also be analyzed utilizing the Navigator 500 sodium's grab sample feature. Measurement accuracy is maintained by the Navigator 500 sodium's fully automatic calibration capability.

The ability to add up to 4 single-stream wet-sections to one transmitter also enables measurement of samples from different points in the process. This not only offers an economic and compact solution, but enables operators to mix-and-match other parameters within the Navigator 500 range.

## Overview of Navigator 500 sodium analyzer



### Transmitter

- Simple navigation and easy-to-use menu system

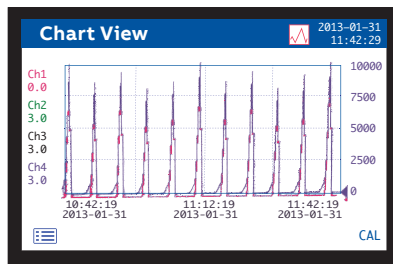

### Graphical trending

- Measurement trends of each connected wet-section can be easily and clearly viewed locally on the graphical color display

| No. | Event          | Date       | Time     |
|-----|----------------|------------|----------|
| 01  | Power Failure  | 2013-01-31 | 11:14:18 |
| 02  | Power Recovery | 2013-01-31 | 09:29:39 |
| 03  | Power Failure  | 2013-01-23 | 12:30:29 |
| 04  | Power Recovery | 2013-01-21 | 12:29:44 |

### Full audit trail logs

- Diagnostic messages, alarm events, calibration details and system activity are stored in the transmitter audit logs for review

**Detachable reagent section**  
Easy access for reagent replacement

**Smart board**  
Stores sensor calibration data and calculates measurement result

**Automatic electrode regeneration**  
Ensures sensitivity and accuracy for low level sodium measurement

**Multi-stream capability**  
Analyze up to 3 separate sample streams

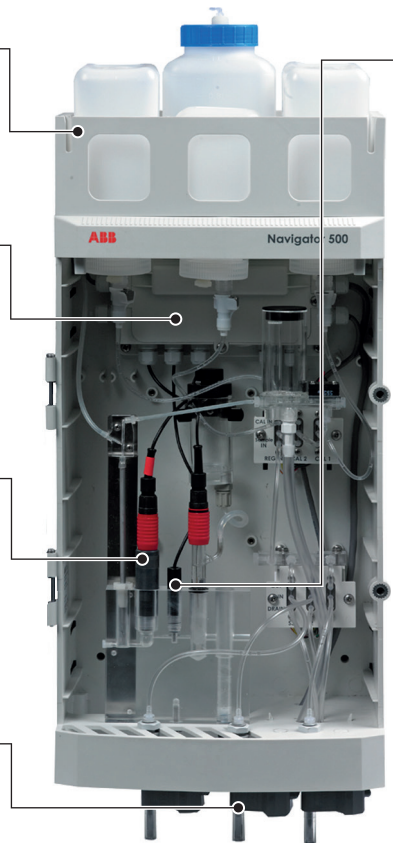

### Continuous sodium measurement using ISE technology

ABB high performance sodium electrode and reference electrode mounted in flow cell with temperature sensor

### Grab sample facility

Easily analyze manually collected samples

### SD card or USB archiving

Data recorded in the transmitter's internal memory can be archived to a removable Secure Digital (SD) card or USB stick

### Flexible communications

A user configurable range of outputs and communication options are available including Ethernet connectivity

### Automatic calibration

Verifies analyzer performance



## Navigator 540 transmitter



Features and benefits of the Navigator 540 transmitter include:

### Connect multiple wet-sections to a single transmitter

- Mix-and-match up to 4 different single-stream wet-sections in the Navigator 500 range

### 'Plug-n-play' capability

- Automatic wet-section recognition and configuration

### Simple to operate

- Intuitive navigation through the operator menus with ABB's standardized 6-key layout

### Password protected security

- Dual access level security, allowing separate user access levels to basic and advanced settings

## Navigator 500 sodium wet-section



The Navigator 550 sodium wet-section has been designed to be used in conjunction with the Navigator 540 transmitter either alone or in combination with other Navigator 550 wet-sections.

The Navigator 550 sodium wet-section features a detachable reagent section, enabling easy access for reagent replacement.



---

## Accurate and reliable measurement

The Navigator 500 sodium analyzer has been designed for ease-of-use and maintenance simplicity, while offering the benefits of flexible communication and advanced data acquisition.

### Measuring principle

The sample enters the analyzer and passes through the sample valve manifold and the calibration valve manifold to the constant head unit that removes the effect of changes in sample pressure and flow-rate.

The sample is then delivered to the entrainment 'T' piece and stainless steel entrainment tube, where an alkaline vapor reagent is added to raise the pH value, before flowing past the sodium and reference electrodes mounted in the flowcell. A temperature sensor, fitted into the flowcell, measures the temperature of the sample. Finally, the sample leaves the flowcell and exits to drain.

The potential developed between the sodium ion-responsive electrode and silver / silver chloride reference electrode is logarithmic with respect to changes in sodium ion concentration.

The signal from the electrode pair and the temperature sensor is connected to the smart board located within the Navigator 500 wet-section where the sodium measurement result is calculated. The accurate measurement result is transferred digitally to the Navigator 540 transmitter.

### Multi-stream analysis

The Navigator 500 sodium is available in single- or multi-stream configurations. The multi-stream option provides up to 3-stream measuring capability allowing different measuring points to be analyzed within the same wet-section.

### Automatic calibration

The Navigator 500 sodium features automatic 2-point calibration that verifies the analyzer's performance against standards of a known concentration. The frequency of automatic calibration can be scheduled by the user to occur from daily to monthly intervals. Calibration can also be initiated manually by the operator.

### Grab sample facility

The Navigator 500 sodium has the flexibility to allow the analyzer to be used for individual measurements in a grab sample mode. This useful feature only requires manual initiation by the operator allowing samples from different points of the process to be collected and analyzed with minimal effort.

Once initiated, the analyzer stops the sample flow allowing the grab sample to be measured. Once measurement is complete the measurement result is stored with the audit log and the analyzer automatically returns to continuous measurement mode.

### Automatic electrode regeneration

The Navigator 500 sodium is available with fully automatic electrode regeneration.

When measuring very low concentrations of sodium continuously over prolonged periods of time, sodium ISEs can become de-sensitized and unable to respond quickly to changes in sodium concentration.

The Navigator 500 sodium analyzer overcomes this issue by automatically introducing a specially formulated regeneration solution to the sodium electrode that removes the unresponsive layer on the electrode surface resulting in a regenerated layer of ion receptors, effectively 'wakening up' the electrode.

Electrode regeneration can be initiated manually by the user or scheduled automatically before a calibration.



### ... Accurate and reliable measurement

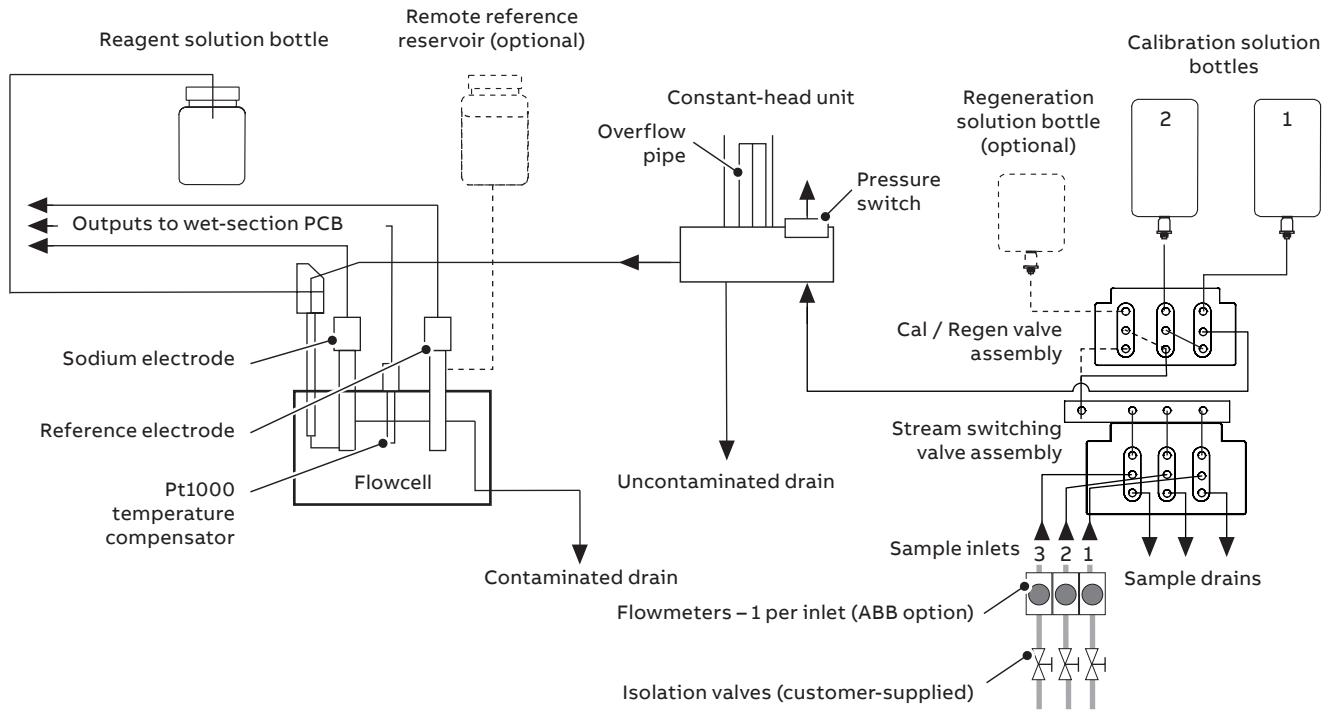

Figure 2 Schematic flow diagram – sodium multi-stream

---

## Specification – system

### Operation

#### Measuring range

0.01 to 10,000 ppb

#### Units of measure

ppb, µg/l, µg/kg

#### Accuracy

±5 % of reading or ±0.1 ppb, whichever is the greater (applies only when sample is within ±5 °C of calibration temperature)

#### Repeatability

±5 % of reading or ±0.1 ppb, whichever is the greater (applies within a ±5 °C [±9 °F] variation)

#### Response time

1 to 100 ppb <4 mins;  
100 to 1 ppb <4 mins for a 90 % step change

#### Multi-stream measurement

Sample time programmable between 10 and 60 min.

#### Resolution

0.001 ppb

#### Temperature compensation

5 to 55 °C (41 to 131 °F) automatic using a Pt1000

#### AutoCal frequency

Programmable from 1 to 7 days or 1 to 8 weeks

#### Sample temperature

5 to 55 °C (41 to 131 °F)

#### Sample pressure

1.5 bar gauge (21.7 psi) maximum

#### Sample flow rate

100 to 400 ml/min

#### Sample connections

1/4 in. ID flexible tubing to barbed connector

### Environmental data

#### Ambient operating temperature:

0 to 55 °C (32 to 131 °F)

#### Ambient operating humidity:

Up to 95 % RH non-condensing

#### Storage temperature:

–20 to 70 °C (–4 to 158 °F) without sensor

0 to 55 °C (41 to 131 °F) with sensor

### Approvals, certification and safety

#### Safety approval

cULus

#### CE mark

Covers EMC & LV Directives  
(including latest version EN 61010)

#### General safety

EN61010-1  
Pollution category 2  
Insulation category 2

### EMC

#### Emissions & immunity

Meets requirements of IEC61326 for an industrial environment and domestic emissions

#### Maintenance

Periodic calibration:  
User-defined

---

## Specification – wet-section

### Mechanical data

#### Protection

IP54

#### Dimensions

##### Height:

668 mm (26.30 in), including solution bottles

##### Width:

290 mm (11.41 in) – door shut

##### Depth:

185 mm (7.28 in) door closed – minimum  
(excluding fixing brackets)

##### Weight:

4.5 kg (10 lb)

### Electrical

#### Power supply ranges (supplied by transmitter)

24 V DC max.

#### Power consumption

8 W max.

## Specification – transmitter

### Operation

#### Display

89 mm (3.5 in) color 1/4 VGA TFT, liquid crystal display (LCD) with built-in backlight and brightness / contrast adjustment

#### Language

English, German, French, Italian, Spanish

#### Keypad

6 tactile membrane keys:  
Group select / left cursor, view select / right cursor, menu key, up, down, enter key

#### No of inputs

Up to 4 single-stream or 1 multi-stream wet-section.

### Mechanical data

#### Protection

IP66 / NEMA 4X

#### Dimensions

Height:  
194 mm (7.64 in) minimum (excluding glands)  
Width:  
214 mm (8.42 in) – excluding glands  
Depth:  
98 mm (3.85 in) door closed – minimum (excluding fixing brackets)  
Weight:  
1.5 kg (3.3 lb)

#### Materials of construction

Glass-filled polycarbonate

### Security

#### Password protection

Calibrate and Advanced – user-assigned  
Service level access – factory-set

### Electrical

#### Power supply ranges

100 to 240 V AC max., 50 / 60 Hz  $\pm 10\%$   
(90 to 264 V AC, 45/65 Hz)

#### Power consumption

<30W

#### Terminal connections rating

AWG 26 to 16 (0.14 to 1.5 mm<sup>2</sup>)

#### Analog outputs

2 standard  
2 optional  
Galvanically isolated from the rest of the circuitry, 500 V for 1 minute. Range-programmable source and range 0 to 22 mA, maximum load 750 W @ 20 mA

#### Relay outputs

4 standard  
2 optional  
Fully-programmable. Contacts rated at 2 A @ 110 / 240 V. Standard relays are changeover. Optional relays are normally closed (N/C).

#### Digital inputs / outputs

6 standard, user-programmable as input or output  
Minimum input pulse duration: 125 mS  
Input:  
volt-free or 24 VDC (conforms to IEC 61131-2)  
Output:  
open-collector, 30 V, 100 mA max.  
(conforms to IEC 61131-2)

### Connectivity / communications

#### Ethernet (optional)

TCP/IP, HTTP

### Data logging

#### Storage

Measurement value storage (programmable sample rate)  
Audit Log\*, Alarms Log\*, Calibration log, Diagnostics log, Configuration changes

#### Chart view

On local display

#### Historical review

Of data

#### Data transfer

Secure digital (SD) card interface / USB stick – Windows-compatible FAT file system, data and log files in Excel and DataManager Pro compatible formats

\*Audit Log and Alarm Log data are stored in the same log file.

## Overall dimensions

### Transmitter

Dimensions in mm (in.)

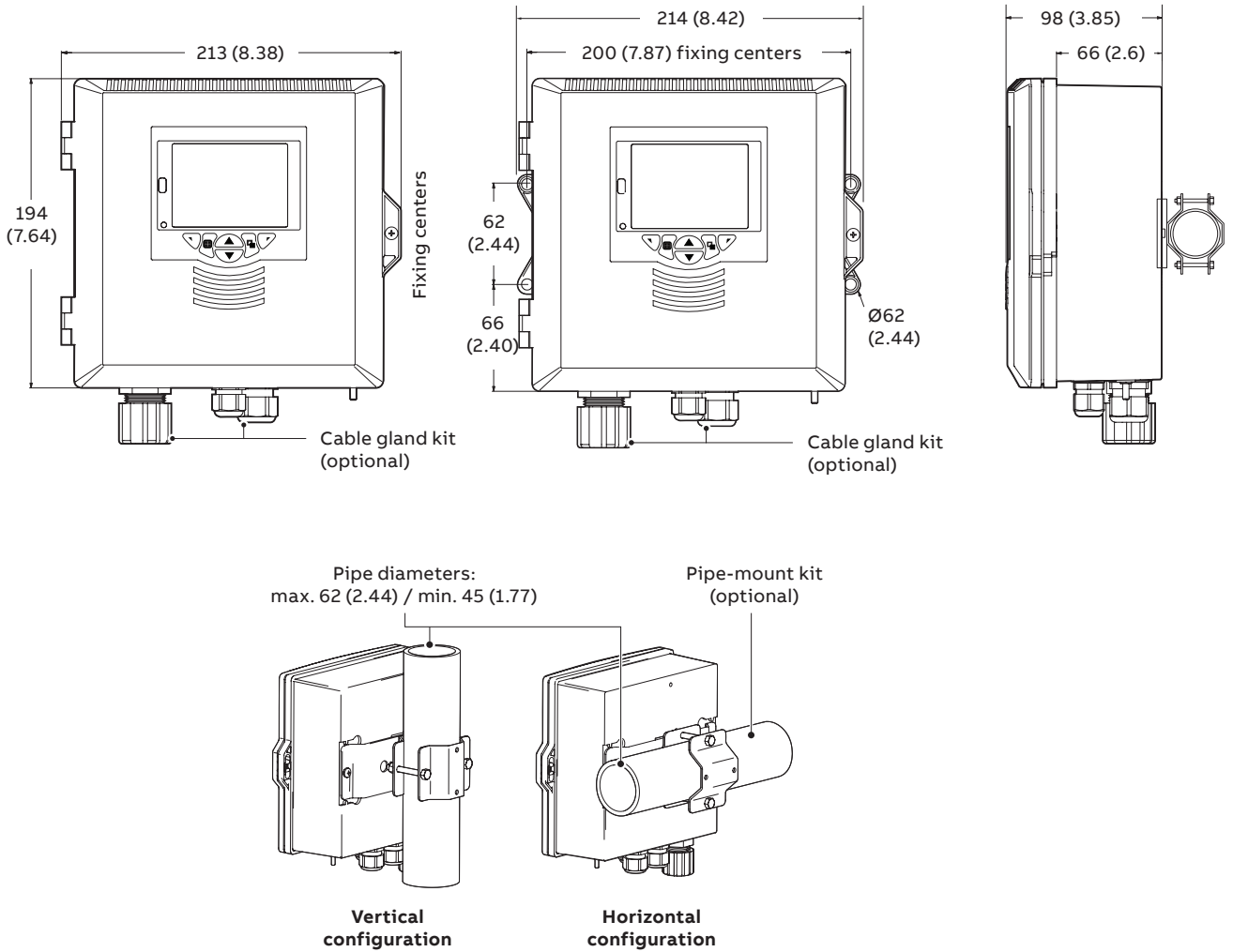

**Wet-section**

Dimensions in mm (in.)

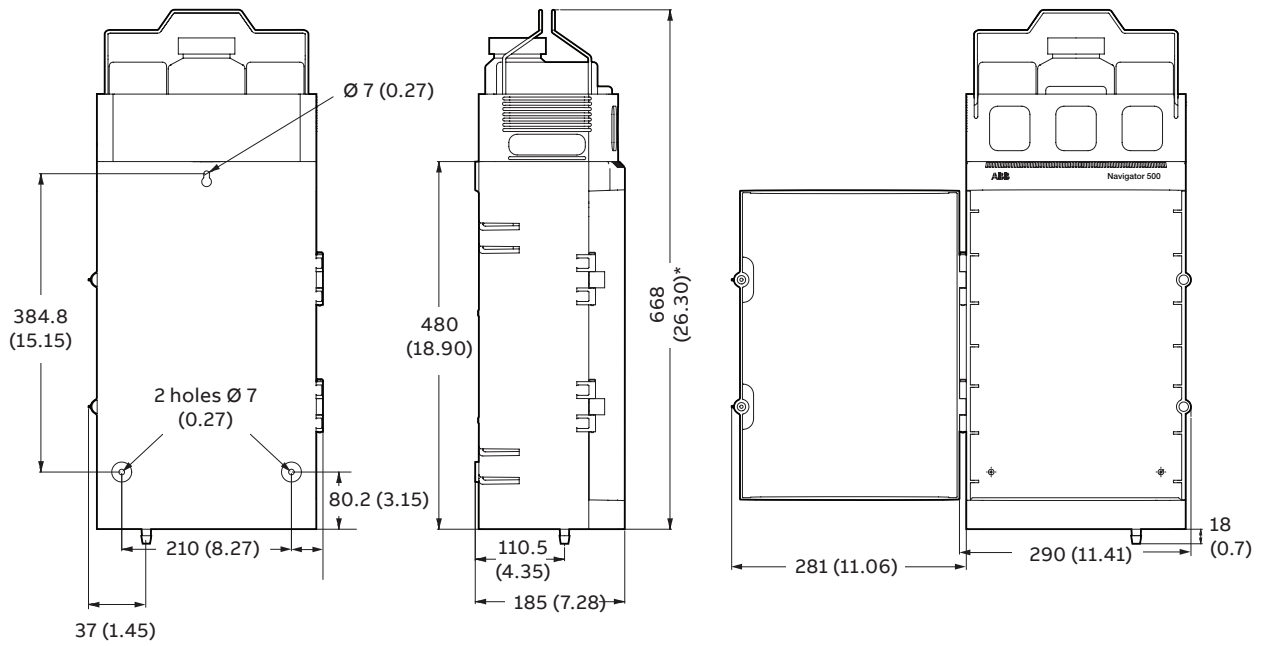

\*When installing, allow a further 60 mm (2.36 in.) min. to remove the bottle carrier assembly, or 135 mm (5.31 in.) min. to remove the calibration solution bottle from the carrier.



# Electrical connections

## Transmitter

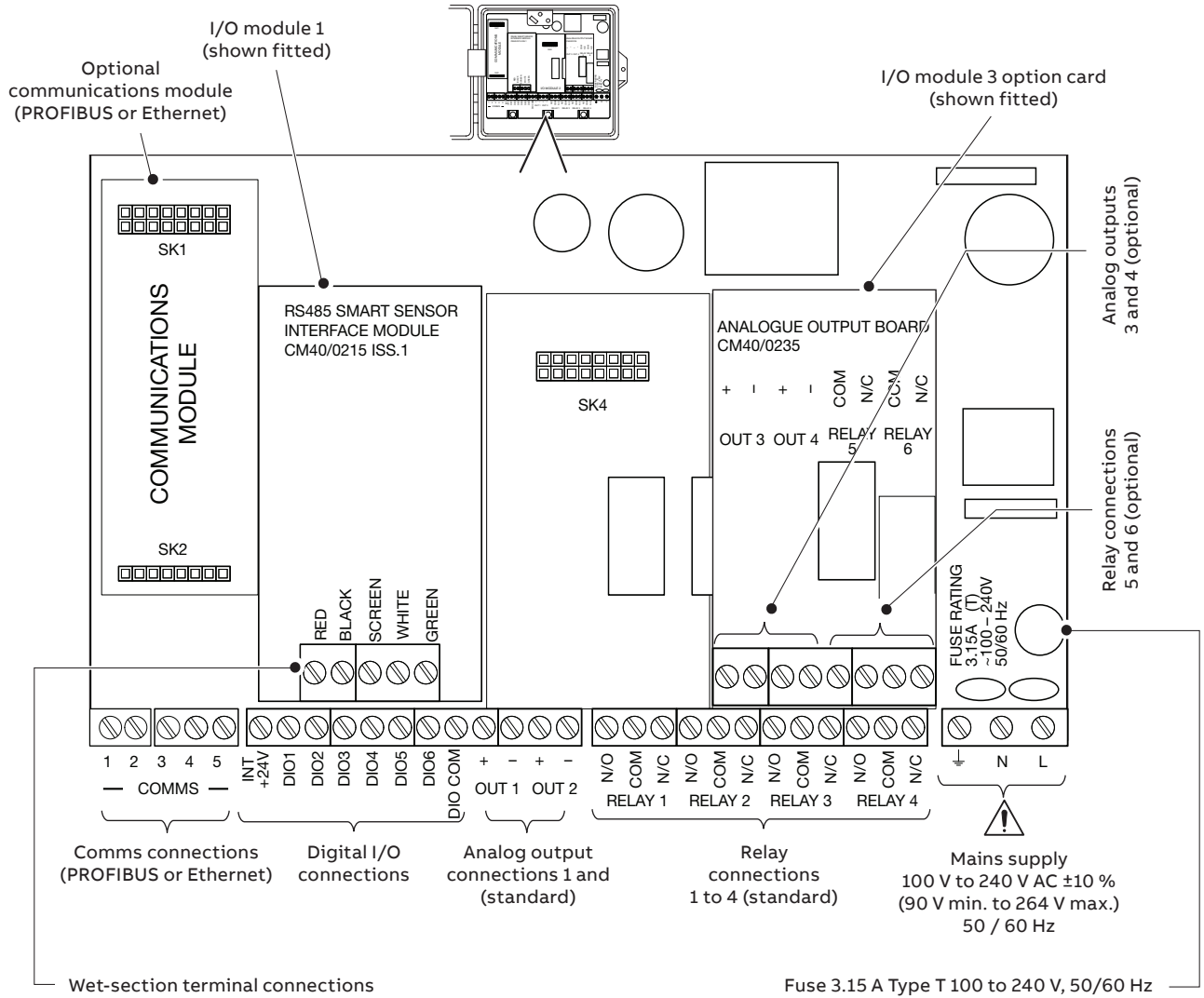

**Digital I/O, relays and analog output**

**Relays (1 to 4)**

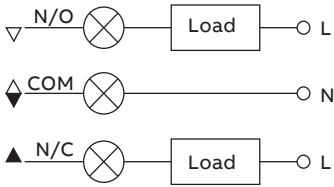

**Relays (5 and 6)**

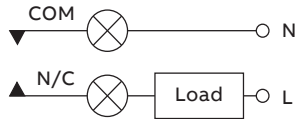

**Digital output**

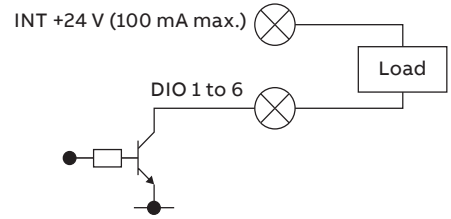

**Analog outputs (1 to 4)**

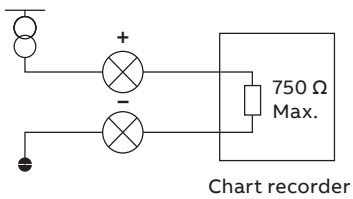

**Digital input (24 volt)**

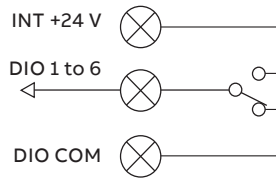

**Digital input (voltage-free)**

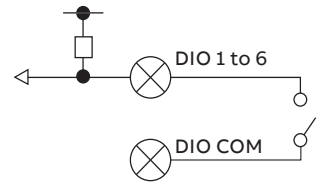

**Wet-section**

(applicable only to multiple wet-section systems)

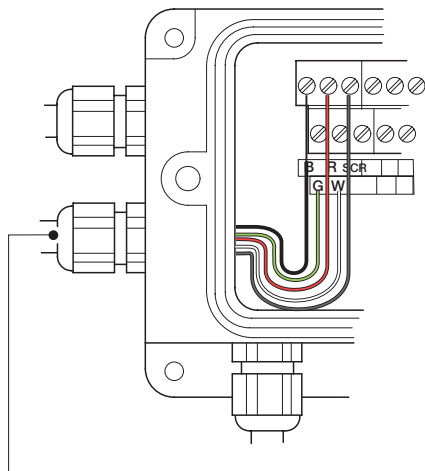

**Additional serial cable connections to multiple wet-sections**

- Red - R (24 V)
- Black - B (0 V)
- Green - G (Data +ve)
- White - W (Data -ve)
- Screen - SCR

## Ordering Information

### Wet-section

|  |                |          |          |          |          |           |           |           |           |            |           |           |
|--|----------------|----------|----------|----------|----------|-----------|-----------|-----------|-----------|------------|-----------|-----------|
| <b>Navigator 500 dissolved SODIUM analyzer</b>   | <b>ASO550/</b> | <b>X</b> | <b>X</b> | <b>X</b> | <b>X</b> | <b>XX</b> | <b>XX</b> | <b>XX</b> | <b>XX</b> | <b>XXX</b> | <b>XX</b> | <b>XX</b> |
| <b>Build revision</b>  |                |          |          |          |          |           |           |           |           |            |           |           |
| Reserved   |                | A        |          |          |          |           |           |           |           |            |           |           |
| <b>Measurement range</b>   |                |          |          |          |          |           |           |           |           |            |           |           |
| Standard (0.01 TO 10,000 ppb)  |                |          |          |          | 1        |           |           |           |           |            |           |           |
| <b>Enclosure type</b>  |                |          |          |          |          |           |           |           |           |            |           |           |
| Wall   |                |          |          |          |          | W         |           |           |           |            |           |           |
| <b>Number of streams</b>   |                |          |          |          |          |           |           |           |           |            |           |           |
| Single stream  |                |          |          |          |          |           |           |           |           |            |           | 1         |
| Triple stream  |                |          |          |          |          |           |           |           |           |            |           | 3         |
| <b>Sensor type</b>   |                |          |          |          |          |           |           |           |           |            |           |           |
| Standard (non reservoir-fed)   |                |          |          |          |          |           |           |           |           |            |           | S1        |
| Reservoir-fed junction   |                |          |          |          |          |           |           |           |           |            |           | S2        |
| Without sensor – standard  |                |          |          |          |          |           |           |           |           |            |           | Y0        |
| Without sensor – reservoir   |                |          |          |          |          |           |           |           |           |            |           | Y1        |
| <b>Process connection type</b>   |                |          |          |          |          |           |           |           |           |            |           |           |
| 6 mm fitting   |                |          |          |          |          |           |           |           |           |            |           | A1        |
| 1/4 in. fitting  |                |          |          |          |          |           |           |           |           |            |           | B1        |
| <b>Optional ordering codes</b>   |                |          |          |          |          |           |           |           |           |            |           |           |
| Add 1 or more of the following codes after the standard ordering information to select any additional options. |                |          |          |          |          |           |           |           |           |            |           |           |
| <b>Sample measurement options</b>  |                |          |          |          |          |           |           |           |           |            |           |           |
| Sample flow measurement  |                |          |          |          |          |           |           |           |           |            |           | S1        |
| <b>Additional functions</b>  |                |          |          |          |          |           |           |           |           |            |           |           |
| Automatic electrode regeneration   |                |          |          |          |          |           |           |           |           |            |           | N3        |
| Signal cable length and type (supplied without signal cable as standard)                                       |                |          |          |          |          |           |           |           |           |            |           |           |
| 1.5 m (approx. 5 ft) cable, terminal connection  |                |          |          |          |          |           |           |           |           |            |           | SC1       |
| 5 m (approx. 15 ft) cable, terminal connection   |                |          |          |          |          |           |           |           |           |            |           | SC2       |
| 10 m (approx. 30 ft) cable, terminal connection  |                |          |          |          |          |           |           |           |           |            |           | SC3       |
| 20 m (approx. 60 ft) cable, terminal connection  |                |          |          |          |          |           |           |           |           |            |           | SC4       |
| <b>Test certificate</b>  |                |          |          |          |          |           |           |           |           |            |           |           |
| Test certificate   |                |          |          |          |          |           |           |           |           |            |           | CD        |
| <b>Documentation language* (supplied in English as standard)</b>   |                |          |          |          |          |           |           |           |           |            |           |           |
| German   |                |          |          |          |          |           |           |           |           |            |           | M1        |
| Italian  |                |          |          |          |          |           |           |           |           |            |           | M2        |
| Spanish  |                |          |          |          |          |           |           |           |           |            |           | M3        |
| French   |                |          |          |          |          |           |           |           |           |            |           | M4        |
| English  |                |          |          |          |          |           |           |           |           |            |           | M5        |

\*Commissioning instructions are supplied with each transmitter.  
 Comprehensive operating instructions are available as a free download from [www.abb.com](http://www.abb.com) or printed copies can be ordered as additional items.







**Transmitter**

| Navigator 540 transmitter  | AWT540/ | X | X | X | X | XX | XX | XX | XX | XX | XX | XX | XX | XX |
|--|---------|---|---|---|---|----|----|----|----|----|----|----|----|----|
| <b>Build revision</b>  |         |   |   |   |   |    |    |    |    |    |    |    |    |    |
| Reserved   | A       |   |   |   |   |    |    |    |    |    |    |    |    |    |
| <b>Enclosure type</b>  |         |   |   |   |   |    |    |    |    |    |    |    |    |    |
| Wall mount   |         | 1 |   |   |   |    |    |    |    |    |    |    |    |    |
| <b>Display type</b>  |         |   |   |   |   |    |    |    |    |    |    |    |    |    |
| Color (standard)   |         |   | A |   |   |    |    |    |    |    |    |    |    |    |
| <b>Power supply</b>  |         |   |   |   |   |    |    |    |    |    |    |    |    |    |
| 90 to 260 V AC, 50 to 60 Hz  |         |   |   | 1 |   |    |    |    |    |    |    |    |    |    |
| <b>Channel 1</b>   |         |   |   |   |   |    |    |    |    |    |    |    |    |    |
| Digital, wired sensor connection   |         |   |   |   |   | B1 |    |    |    |    |    |    |    |    |
| Without  |         |   |   |   |   | Y0 |    |    |    |    |    |    |    |    |
| Reserved   |         |   |   |   |   |    | Y0 |    |    |    |    |    |    |    |
| Reserved   |         |   |   |   |   |    |    | Y0 |    |    |    |    |    |    |
| <b>Output signal</b>   |         |   |   |   |   |    |    |    |    |    |    |    |    |    |
| Without  |         |   |   |   |   |    |    |    | Y0 |    |    |    |    |    |
| Additional output card (2 current outputs + 2 relays)  |         |   |   |   |   |    |    |    | Y2 |    |    |    |    |    |
| Ethernet   |         |   |   |   |   |    |    |    | E1 |    |    |    |    |    |
| Profibus DPV1  |         |   |   |   |   |    |    |    | D1 |    |    |    |    |    |
| <b>Data storage</b>  |         |   |   |   |   |    |    |    |    |    |    |    |    |    |
| Without  |         |   |   |   |   |    |    |    |    | Y0 |    |    |    |    |
| SD card function   |         |   |   |   |   |    |    |    |    | D1 |    |    |    |    |
| USB function   |         |   |   |   |   |    |    |    |    | D8 |    |    |    |    |
| <b>Optional ordering codes</b>   |         |   |   |   |   |    |    |    |    |    |    |    |    |    |
| Add 1 or more of the following codes after the standard ordering information to select any additional options. |         |   |   |   |   |    |    |    |    |    |    |    |    |    |
| <b>Accessories</b>   |         |   |   |   |   |    |    |    |    |    |    |    |    |    |
| Panel mount kit  |         |   |   |   |   |    |    |    |    |    |    | A2 |    |    |
| <b>Test certificate</b>  |         |   |   |   |   |    |    |    |    |    |    |    |    |    |
| Test certificate   |         |   |   |   |   |    |    |    |    |    |    |    | CD |    |
| <b>Documentation language * (supplied in English as standard)</b>  |         |   |   |   |   |    |    |    |    |    |    |    |    |    |
| German   |         |   |   |   |   |    |    |    |    |    |    |    |    | M1 |
| Italian  |         |   |   |   |   |    |    |    |    |    |    |    |    | M2 |
| Spanish  |         |   |   |   |   |    |    |    |    |    |    |    |    | M3 |
| French   |         |   |   |   |   |    |    |    |    |    |    |    |    | M4 |
| English  |         |   |   |   |   |    |    |    |    |    |    |    |    | M5 |
| <b>Cable entry options</b>   |         |   |   |   |   |    |    |    |    |    |    |    |    |    |
| Metric gland pack (9 glands)   |         |   |   |   |   |    |    |    |    |    |    |    |    | U1 |

\* Commissioning instructions are supplied with each transmitter.  
 Comprehensive operating instructions are available as a free download from [www.abb.com](http://www.abb.com) or printed copies can be ordered as additional items.



## Our offering:

|   |  |  |                         |
|---|--|--|-------------------------|
|    | Actuators and Positioners                |    | Analytical Instruments  |
|  | Device Management, Fieldbus and Wireless |   | Flow Measurement        |
|  | Force Measurement                        |   | Level Measurement       |
|  | Natural Gas Measurement                  |   | Pressure Measurement    |
|  | Recorders and Controllers                |  | Temperature Measurement |

---

HMI – Automação e Instrumentação, Lda.

---

Rua dos 5 Caminhos, nº 570  
4780-382 Santo Tirso  
PORTUGAL

Tel. +351 252 850 501  
Fax. +351 300 013 487

Web: [www.hmi.pt](http://www.hmi.pt)

Email: [hmi@hmi.pt](mailto:hmi@hmi.pt)

---

**ABB Limited**  
**Measurement & Analytics**  
Oldends Lane  
Stonehouse  
Gloucestershire GL10 3TA  
UK  
Tel: +44 (0)1453 826 661  
Fax: +44 (0)1453 829 671  
Mail: [instrumentation@gb.abb.com](mailto:instrumentation@gb.abb.com)

**ABB Inc.**  
**Measurement & Analytics**  
125 E. County Line Road  
Warminster, PA 18974  
USA  
Tel: +1 215 674 6000  
Fax: +1 215 674 7183

[abb.com/measurement](http://abb.com/measurement)

We reserve the right to make technical changes or modify the contents of this document without prior notice. With regard to purchase orders, the agreed particulars shall prevail. ABB does not accept any responsibility whatsoever for potential errors or possible lack of information in this document.

We reserve all rights in this document and in the subject matter and illustrations contained therein. Any reproduction, disclosure to third parties or utilization of its contents – in whole or in parts – is forbidden without prior written consent of ABB.

© Copyright 2017 ABB.  
All rights reserved.