



hmi

high-accuracy
measurement
instruments

FICHA TÉCNICA DE PRODUTO

PRODUCT DATASHEET

HMI – Automação e Instrumentação, Lda.

Travessa da Indústria, nº 111
4780-573 Santo Tirso
PORTUGAL

Tel. +351 252 850 501
Fax. +351 300 013 487

Web: www.hmi.pt

Email: hmi@hmi.pt

ABB MEASUREMENT & ANALYTICS | DATA SHEET | DS/AHM550-EN REV. H

Navigator 500

Hydrazine analyzer



Measurement made easy

Accurate and reliable measurement of hydrazine in high purity water

Fast response time

- reduce chemical costs through optimized dosing to feedwater

Low cost of ownership

- low reagent consumption provides up to 8 weeks continuous measurement
- 'pumpless' design with no moving parts reduces maintenance requirements

Integrated constant-head unit

- controls sample flow at optimum level during pressure fluctuations, simplifying installation and commissioning

Automatic pH buffering and temperature compensation

- maintains accurate measurement during unstable process conditions, ensuring optimal dosing and minimizing chemical usage

Comprehensive diagnostics

- provides sensor condition and analyzer status data

Connect multiple wet-sections to a single transmitter

- reduces footprint and installation costs

The Navigator 500 range

The Navigator 500 range of analyzers from ABB are designed for high purity water treatment applications and power cycle chemistry monitoring.

The analysis and signal conditioning is conducted within the Navigator 550's advanced wet-section that houses the sensing technology. The accurate measurement result is transmitted digitally to the Navigator 540 transmitter.

The Navigator 540 universal transmitter enables connection of up to 4 different Navigator 550 wet-sections and is available with optional features such as SD card data retrieval and graphical trending, as well as additional outputs and communication options.

The following parameters are available in the Navigator 500 range:

Navigator 500

- Dissolved oxygen
- Sodium
- Hydrazine

Navigator 500 hydrazine

The Navigator 500 hydrazine provides continuous monitoring and control of power station boiler feed water/ steam condensate.

The wet section houses ABB's uniquely designed electrochemical cell that accurately measures the amount of hydrazine in the water. This accuracy is reinforced by automatic pH buffering and temperature compensation, ensuring that readings reflect the actual feedwater conditions.

Measurement results are updated digitally to the Navigator 540 transmitter where process trends of up to 4 separate wet-sections can be viewed locally on the color display. Users of this system also benefit from the Navigator 500 hydrazine's low maintenance requirements, ease-of-use, simple calibration and proven sensing performance. Process data, together with the content of alarm and audit logs within the transmitter, can be saved to removable media for record keeping and analysis using ABB's DataManager Pro data analysis software.

Navigator 500 transmitter



Sodium
Hydrazine
Dissolved oxygen

Navigator 550 wet-sections



Sodium



Hydrazine



Dissolved oxygen

Figure 1 Navigator 500 family

Applications

Typical applications for the Navigator 500 hydrazine analyzer include:

- Monitoring and control of hydrazine dosing of boiler feedwater
- Monitoring dosing efficiency prior to economizer inlet

Hydrazine in boiler feedwater

The need for accurate dosing

To reduce dissolved oxygen levels, boiler feedwater is commonly dosed with hydrazine before it enters the boiler. Typically, dosing in a ratio of 3 parts hydrazine to the expected level of dissolved oxygen enables operators to achieve an acceptable concentration of below 5µgkg⁻¹.

Hydrazine also reacts with soft haematite layers on the boiler tubes, forming a hard magnetite layer that protects the tubes from further corrosion.

To ensure that the correct amount of hydrazine is added to the boiler feedwater, measurements must be taken at both the point of dosing and the economizer feedwater inlet. Adding too little hydrazine results in higher levels of dissolved oxygen in the boiler and impairs the formation of magnetite on the boiler tubes, reducing their resistance to corrosion. Adding too much is unnecessarily wasteful and incurs higher chemical treatment costs.

The Navigator 500 solution

The Navigator 500 hydrazine analyzer provides a continuous measurement of the level of hydrazine in boiler feedwater, enabling the chemical dose to be controlled automatically. The information provided by the analyzer enables the exact dose to be administered in response to the actual level of dissolved oxygen present. This avoids both the expense associated with overdosing and the costly corrosion damage caused by under-dosing.

The ability to add up to 4 wet-sections to one transmitter also enables measurement of samples from different points in the boiler feedwater line. This offers not only an economic and compact solution, it also helps to minimise the risk of under- or over-dosing by providing a precise picture of hydrazine levels between the feedwater dosing and economizer inlet.

Operators are also able to mix-and-match other parameters within the Navigator 500 range, with a single transmitter able to accept readings from ABB's Navigator 550 dissolved oxygen and sodium wet-sections.

Overview of Navigator 500 hydrazine analyzer



Transmitter

- Simple navigation and easy-to-use menu system

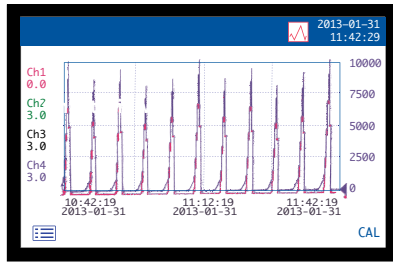

Graphical trending

- Measurement trends of each connected wet-section can be easily and clearly viewed locally on the graphical color display

| No. | Event | Date | Time |
|-----|----------------|------------|----------|
| 01 | Power Failure | 2013-01-31 | 11:14:18 |
| 02 | Power Recovery | 2013-01-31 | 09:29:39 |
| 03 | Power Failure | 2013-01-23 | 12:30:29 |
| 04 | Power Recovery | 2013-01-21 | 12:29:44 |

Full audit trail logs

- Diagnostic messages, alarm events, calibration details and system activity are stored in the transmitter audit logs for review

Low reagent addition

- Easy access for reagent replacement

Smart board

- Stores sensor calibration data and calculates measurement result

Mixing coil

- Reagent is added via microporous disc to provide up to 8 weeks continuous operation
 - No moving parts minimize maintenance requirements

Adjustable constant-head unit

- Provides simple adjustment of sample flow rate to hydrazine sensor
- Stabilizes flow conditions during sample pressure changes

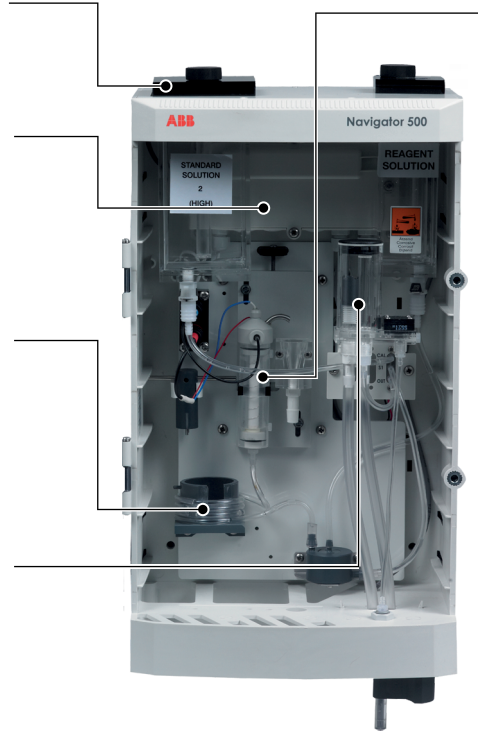

Continuous hydrazine measurement using electrochemical technology

- ABB hydrazine cell can be refurbished by the user to maximize sensor life

SD card or USB archiving

- Data recorded in the transmitter's internal memory can be archived to a removable Secure Digital (SD) card or USB stick

Flexible communications

- A user-configurable range of outputs and communication options are available including Ethernet connectivity

Automatic calibration

- Verifies analyzer performance

Navigator 540 transmitter



Features and benefits of the Navigator 540 transmitter include:

Connect multiple wet-sections to a single transmitter

- Mix-and-match up to 4 different single-stream wet-sections in the Navigator 500 range

'Plug-n-play' capability

- Automatic wet-section recognition and configuration

Simple to operate

- Intuitive navigation through the operator menus with ABB's standardized 6-key layout

Password protected security

- Dual access level security, allowing separate user access levels to basic and advanced settings

Navigator 500 hydrazine wet-section

The Navigator 500 hydrazine wet-section has been designed to be used in conjunction with the Navigator 540 transmitter; either alone or in combination with other Navigator 500 wet-sections.



Accurate and reliable measurement

Accurate and reliable measurement

The Navigator 500 hydrazine analyzer has been designed for ease-of-use and maintenance simplicity, while offering the benefits of flexible communication and advanced data acquisition.

Measuring principle

The sample enters the analyzer via the user-adjustable constant-head unit mounted within the enclosure that removes the effect of changes in sample pressure and flow-rate. Overflow from the constant-head unit drains into a tundish at the bottom of the enclosure.

The constant sample flow passes through the calibration valve manifold into the reagent dosing chamber where an alkali reagent is added via a micro-porous disc to raise the pH of the sample to 10.5. The dosed sample passes through a mixing coil before entering the hydrazine sensor.

The hydrazine sensor comprises a central ceramic tube inside a gel-filled outer jacket. A silver cathode wire is wound round the outer surface of the tube and a spiral platinum anode is inserted down the center.

Sample flows up through the tube, over the platinum anode and out to waste. Electrical contact between the two electrodes is made via the ionic transport through the porous ceramic tube. The resultant current is proportional to the concentration of hydrazine in solution.

The hydrazine sensor and its overflow funnel are mounted on a sub-panel whose height, relative to the standard solution, can be adjusted to provide the correct rate of flow through the sensor.

A temperature sensor, fitted in the hydrazine sensor flowcell, measures the temperature of the sample.

The signal from the hydrazine sensor and the temperature sensor is passed to the smart board located within the Navigator 550 wet-section. The smart board accurately calculates the hydrazine measurement result and transfers it digitally to the Navigator 540 transmitter.

Simple automatic calibration

The Navigator 500 hydrazine analyzer can be easily calibrated against a solution containing a known hydrazine concentration. This not only verifies analyzer performance but also calculates sensor efficiency.

During calibration the sample flow to the sensor is stopped, enabling the calibration standard to be measured. Once the calibration routine is complete, the sensor efficiency is calculated and displayed, providing the user with a valuable indication of sensor life.

Automatic calibrations can be scheduled to occur from daily to monthly, but it is advised to use freshly-prepared calibration standards to ensure maximum accuracy as hydrazine solutions degrade with time.

... Accurate and reliable measurement

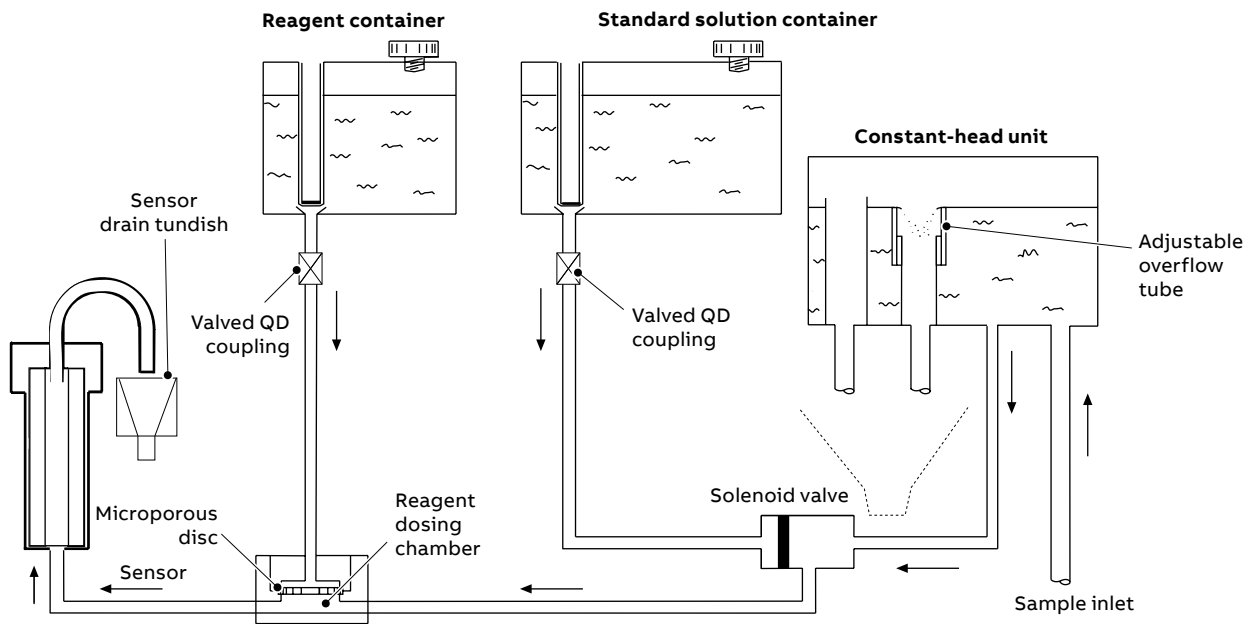

Figure 2 Schematic flow diagram

Specifications – system

Operation

Measuring range
0 to 1000 ppb

Units of measure
ppb, µg/L, µg/kg

Accuracy
±3 % of reading or ±1 ppb, whichever is the greater

Repeatability
±3 % of reading or ±1 ppb, whichever is the greater

Response time
<2 minutes for a 90 % step change

Resolution
0.1 ppb

Temperature compensation
5 to 55 °C (41 to 131 °F) automatic using a Pt1000

AutoCal frequency
Programmable from 1 to 7 days or 1 to 8 weeks

Sample temperature
5 to 55 °C (41 to 131 °F)

Sample pressure
1.5 bar gauge (21.7 psi) maximum

Sample flow rate
100 to 400 mL/min

Sample connections
¼ in ID flexible tubing to barbed connector

Environmental data

Ambient operating temperature:
0 to 55 °C (32 to 131 °F)

Ambient operating humidity:
Up to 95 % RH non-condensing

Storage temperature:
–20 to 70 °C (–4 to 158 °F) without sensor
0 to 55 °C (41 to 131 °F) with sensor

Approvals, certification and safety

Safety approval
cULus

CE mark
Covers EMC & LV Directives
(including latest version EN 61010)

General safety
EN61010-1
Pollution category 2
Insulation category 2

EMC

Emissions & immunity
Meets requirements of IEC61326 for an industrial environment and domestic emissions

Maintenance

Periodic calibration:
User-defined

Specifications – wet-section

Mechanical data

Protection

IP54

Dimensions

Height:

480 mm (18.90 in)

Width:

290 mm (11.41 in) – door shut

Depth:

185 mm (7.28 in) door closed – minimum
(excluding fixing brackets)

Weight:

4.5 kg (10 lb)

Electrical

Power supply ranges (supplied by transmitter)

24 V DC max.

Power consumption

8 W max.

Specifications – transmitter

Operation

Display

89 mm (3.5 in) color ¼ VGA TFT, liquid crystal display (LCD) with built-in backlight and brightness / contrast adjustment

Language

English

Keypad

6 tactile membrane keys:
Group select / left cursor, view select / right cursor, menu key, up, down, enter key

No of inputs

Up to 4 single-stream or 1 multi-stream wet-section.

Mechanical data

Protection

IP66 / NEMA 4X

Dimensions

Height:
194 mm (7.64 in) minimum (excluding glands)
Width:
214 mm (8.42 in) – excluding glands
Depth:
98 mm (3.85 in) door closed – minimum (excluding fixing brackets)
Weight:
1.5 kg (3.3 lb)

Materials of construction

Glass-filled polycarbonate

Security

Password protection

Calibrate and Advanced – user-assigned
Service level access – factory-set

Electrical

Power supply ranges

100 to 240 V AC max., 50/60 Hz ±10 %
(90 to 264 V AC, 45/65 Hz)

Power consumption

<30 W

Terminal connections rating

AWG 26 to 16 (0.14 to 1.5 mm²)

Analog outputs

2 standard
2 optional
Galvanically isolated from the rest of the circuitry, 500 V for 1 minute. Range-programmable source and range 0 to 22 mA, maximum load 750 Ω @ 20 mA

Relay outputs

4 standard
2 optional
Fully-programmable. Contacts rated at 2 A @ 110 / 240 V
Standard relays are changeover. Optional relays are normally closed (N/C).

Digital inputs / outputs

6 standard, user-programmable as input or output
Minimum input pulse duration: 125 mS
Input:
volt-free or 24 VDC (conforms to IEC 61131-2)
Output:
open-collector, 30 V, 100 mA max.
(conforms to IEC 61131-2)

Connectivity / communications

Ethernet (optional)

TCP/IP, HTTP

Data logging

Storage

Measurement value storage (programmable sample rate)
Audit Log*, Alarms Log*, Calibration log, Diagnostics log, Configuration changes

Chart view

On local display

Historical review

Of data

Data transfer

Secure digital (SD) card interface / USB stick – Windows-compatible FAT file system, data and log files in Excel and DataManager Pro compatible formats

*Audit Log and Alarm Log data are stored in the same log file.

Overall dimensions

Transmitter

Dimensions in mm (in)

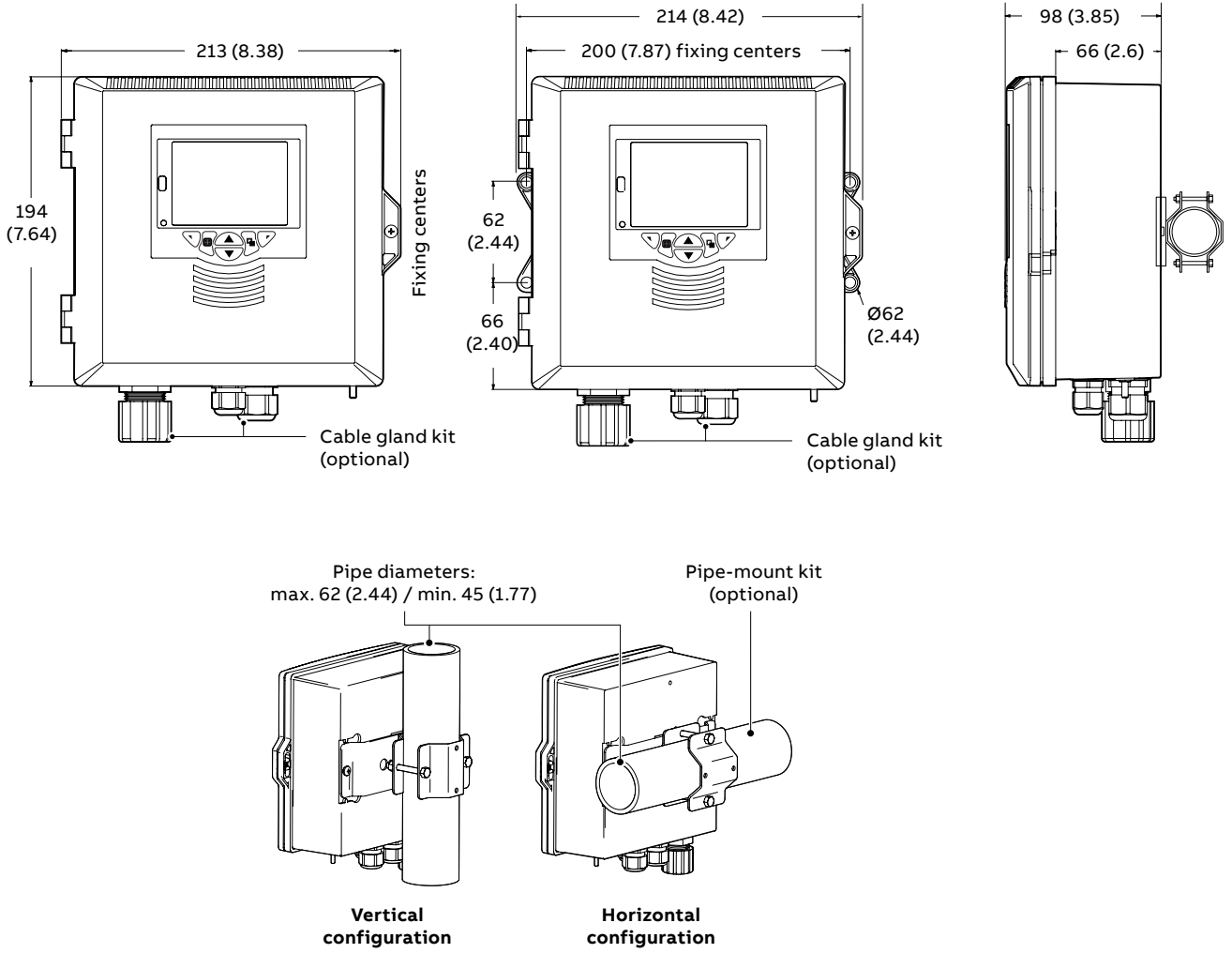

Wet-section

Dimensions in mm (in)

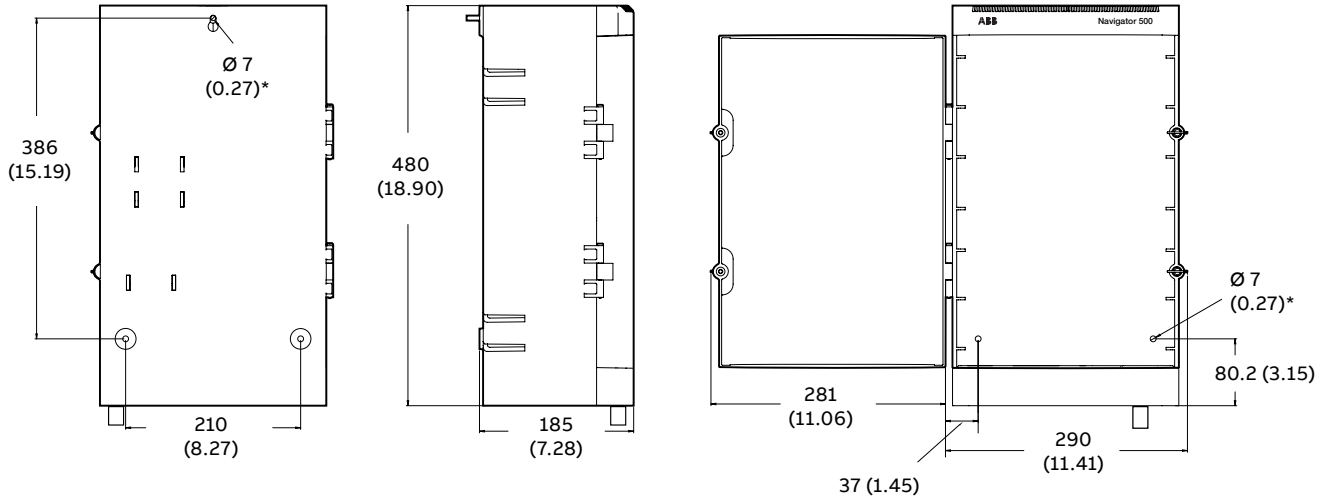

Electrical connections

Transmitter

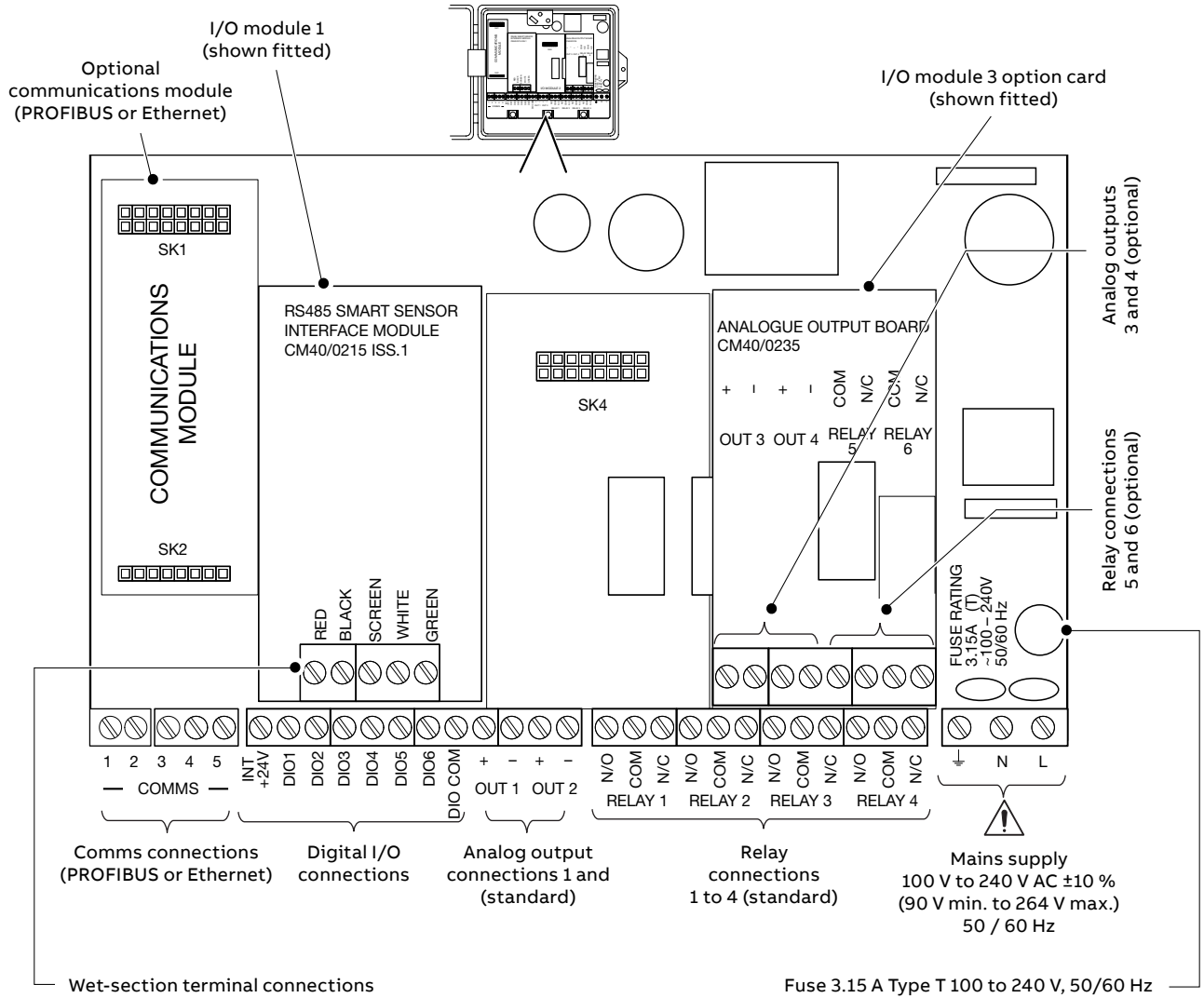

Digital I/O, relays and analog output

Relays (1 to 4)

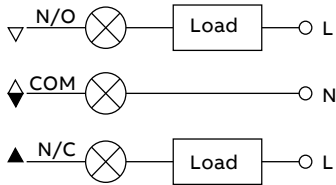

Relays (5 and 6)

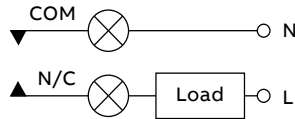

Digital output

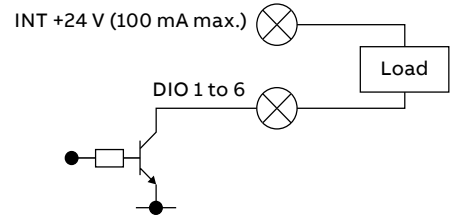

Analog outputs (1 to 4)

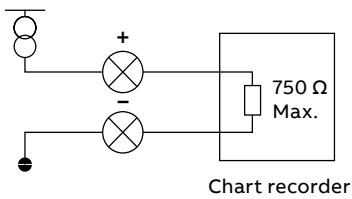

Digital input (24 volt)

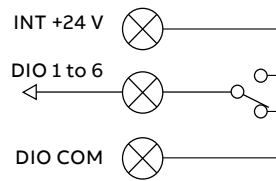

Digital input (voltage-free)

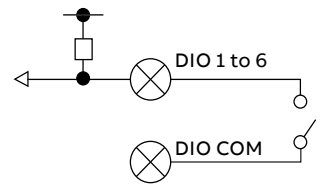

Wet-section

(applicable only to multiple wet-section systems)

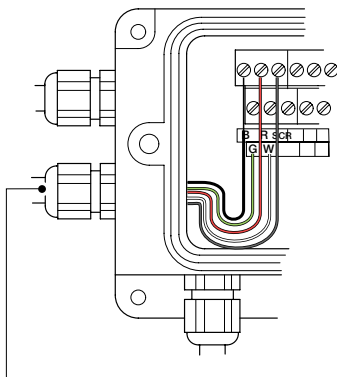

Additional serial cable connections to multiple wet-sections

- Red - R (24 V)
- Black - B (0 V)
- Green - G (Data +ve)
- White - W (Data -ve)
- Screen - SCR

Ordering Information

Wet-section

| | | | | | | | | | | | |
|---|--|---|---|---|---|----|----|----|-----|-----|----|
| Navigator 500 hydrazine analyzer | AHM550/ | X | X | X | X | XX | XX | XX | XXX | XX | XX |
| Build revision | | | | | | | | | | | |
| Reserved | A | | | | | | | | | | |
| Measurement range | | | | | | | | | | | |
| Standard (0 to 1000 ppb) | | | 1 | | | | | | | | |
| Enclosure type | | | | | | | | | | | |
| Wall | | | | W | | | | | | | |
| Number of streams | | | | | | | | | | | |
| Single stream | | | | | 1 | | | | | | |
| Sensor type | | | | | | | | | | | |
| Standard | | | | | | S1 | | | | | |
| Supplied without sensor | | | | | | Y0 | | | | | |
| Process connection type | | | | | | | | | | | |
| 6 mm fitting | | | | | | | | A1 | | | |
| ¼ in fitting | | | | | | | | B1 | | | |
| Optional ordering codes | Add 1 or more of the following codes after the standard ordering information to select any additional options. | | | | | | | | | | |
| Sample measurement options | | | | | | | | | | | |
| Sample flow measurement | | | | | | | | | S1 | | |
| Signal cable length and type (supplied without signal cable as standard) | | | | | | | | | | | |
| 1.5 m (approx. 5 ft) cable, terminal connection | | | | | | | | | | SC1 | |
| 5 m (approx. 15 ft) cable, terminal connection | | | | | | | | | | SC2 | |
| 10 m (approx. 30 ft) cable, terminal connection | | | | | | | | | | SC3 | |
| 20 m (approx. 60 ft) cable, terminal connection | | | | | | | | | | SC4 | |
| Test certificate | | | | | | | | | | | |
| Test certificate | | | | | | | | | | | CD |
| Documentation language * (supplied in English as standard) | | | | | | | | | | | |
| English | | | | | | | | | | | M5 |

* Commissioning instructions are supplied with each transmitter.

Comprehensive operating instructions are available as a free download from www.abb.com or printed copies can be ordered as additional items.

Transmitter

| Navigator 540 transmitter | AWT540/ | X | X | X | X | XX | XX | XX | XX | XX | XX | XX | XX | XX |
|--|---------|---|---|---|---|----|----|----|----|----|----|----|----|----|
| Build revision | | | | | | | | | | | | | | |
| Reserved | A | | | | | | | | | | | | | |
| Enclosure type | | | | | | | | | | | | | | |
| Wall mount | 1 | | | | | | | | | | | | | |
| Display type | | | | | | | | | | | | | | |
| Color (standard) | A | | | | | | | | | | | | | |
| Power supply | | | | | | | | | | | | | | |
| 90 to 260 V AC, 50 to 60 Hz | 1 | | | | | | | | | | | | | |
| Channel 1 | | | | | | | | | | | | | | |
| Digital, wired sensor connection | | | | | | B1 | | | | | | | | |
| Without | | | | | | Y0 | | | | | | | | |
| Reserved | | | | | | | Y0 | | | | | | | |
| Reserved | | | | | | | | Y0 | | | | | | |
| Output signal | | | | | | | | | | | | | | |
| Without | | | | | | | | Y0 | | | | | | |
| Additional output card (2 current outputs + 2 relays) | | | | | | | | Y2 | | | | | | |
| Ethernet | | | | | | | | E1 | | | | | | |
| Profibus DPV1 | | | | | | | | D1 | | | | | | |
| Data storage | | | | | | | | | | | | | | |
| Without | | | | | | | | | Y0 | | | | | |
| SD card function | | | | | | | | | D1 | | | | | |
| USB function | | | | | | | | | D8 | | | | | |
| Optional ordering codes | | | | | | | | | | | | | | |
| Add 1 or more of the following codes after the standard ordering information to select any additional options. | | | | | | | | | | | | | | |
| Accessories | | | | | | | | | | | | | | |
| Panel mount kit | | | | | | | | | | | | A2 | | |
| Test certificate | | | | | | | | | | | | | | |
| Test certificate | | | | | | | | | | | | | CD | |
| Documentation language * (supplied in English as standard) | | | | | | | | | | | | | | |
| English | | | | | | | | | | | | | | M5 |
| Cable entry options | | | | | | | | | | | | | | |
| Metric gland pack (9 glands) | | | | | | | | | | | | | | U1 |

* Commissioning instructions are supplied with each transmitter.
 Comprehensive operating instructions are available as a free download from www.abb.com or printed copies can be ordered as additional items.



Notes

Sales



Service



Software



ABB Measurement & Analytics

For your local ABB contact, visit:
www.abb.com/contacts

For more product information, visit:
www.abb.com/measurement











We reserve the right to make technical changes or modify the contents of this document without prior notice. With regard to purchase orders, the agreed particulars shall prevail. ABB does not accept any responsibility whatsoever for potential errors or possible lack of information in this document.

We reserve all rights in this document and in the subject matter and illustrations contained therein. Any reproduction, disclosure to third parties or utilization of its contents – in whole or in parts – is forbidden without prior written consent of ABB.

© Copyright 2024 ABB.
All rights reserved.



Our offering:

| | |
|---|---|
|  <p>Actuators and Positioners</p> |  <p>Analytical Instruments</p> |
|  <p>Device Management, Fieldbus and Wireless</p> |  <p>Flow Measurement</p> |
|  <p>Force Measurement</p> |  <p>Level Measurement</p> |
|  <p>Natural Gas Measurement</p> |  <p>Pressure Measurement</p> |
|  <p>Recorders and Controllers</p> |  <p>Temperature Measurement</p> |

HMI – Automação e Instrumentação, Lda.

Travessa da Indústria, nº 111
4780-573 Santo Tirso
PORTUGAL

Tel. +351 252 850 501
Fax. +351 300 013 487

Web: www.hmi.pt

Email: hmi@hmi.pt