



hmi

high-accuracy
measurement
instruments

FICHA TÉCNICA DE PRODUTO

PRODUCT DATASHEET

HMI – Automação e Instrumentação, Lda.

Travessa da Indústria, nº 111
4780-573 Santo Tirso
PORTUGAL

Tel. +351 252 850 501
Fax. +351 300 013 487

Web: www.hmi.pt

Email: hmi@hmi.pt

Models A6100 & A6200 Purgemaster 'SNAP-IN' Small Flowmeter

Long-term reliable
performance flowmeters with
low cost-of-ownership

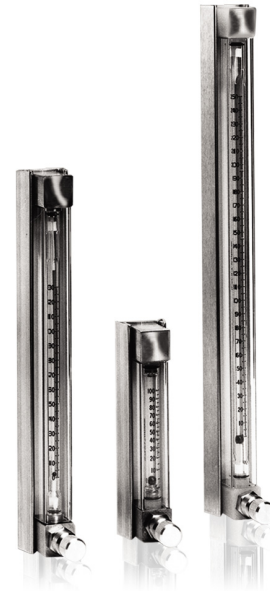

High strength stainless steel body

- the body is corrosion resistant stainless steel, rigidly constructed to maintain tube alignment and resist pipe strain

'SNAP-IN' tube construction

- minimizes the downtime needed to clean the meter tube or to change the meter range

Polycarbonate operator protection shield

- safety tested shield protects personnel from glass fragments in the rare event of accidental tube breakage

Component flexibility

- all parts for the three scale lengths except bodies, tubes and protector shields are interchangeable

Internal backcheck

- restricts back flow and draining of process fluid when metering tube is removed

Choice of operating position

- the meter can be inverted and its tube reversed to change the control valve position from the inlet to the outlet

Options of valve, DP regulator and alarms

ATEX-approved versions available both with and without alarms

- II 2GD approval without alarms; II 2G approval with alarms

Introduction

ABB Purgemaster Flowmeters are low capacity variable area flowmeters for both liquid and gas with an excellent selection of material and scale lengths in a single product family design. They provide optimum flexibility with a minimum number of components. The meter features a corrosion resistant, high strength stainless steel body, quick, easy snap-in tube construction and a safety tested operator protection shield.

A differential pressure regulator is available, which will maintain a constant flowrate of a liquid or gas even when there are pressure variations. It is supplied piped into the meter as an assembly, ready to use.

A constant liquid or gas flowrate is achieved by creating a constant pressure drop. Manually changing the needle valve setting on the flowmeter changes the flowrate value. The differential pressure regulator then maintains this constant flowrate even when the pressure varies.

However when metering gases their compressibility means that – although the supply pressure can change - the downstream pressure must be fixed, if the volume flowrate is to be held at the set value.

In addition, one or two inductive ring sensor alarms can be fitted to certain model variants. These enable High, Low or even High and Low flow trip points to be set and a solid state status signal transmitted. If external switching of signals is to be initiated by these sensors, additional amplifiers/relays should be used.

ABB Purgemasters are ideal for applications such as the purging of control lines and instrument enclosures. Their use is easily extended into fluid sampling, liquid specific gravity, level measurement and similar services.

Specification

Measuring ranges

See measuring ranges on pages 3, 4 and 5

Rangeability

≥10:1

Scale design

% or direct reading scales
Dt/Df ratio scale, millimeters

Accuracy classes (VDE/VDI 3513)

5 in. scale length	
1/4 in. & 1/8 in. tube diameter	2.5
1/16 in. tube diameter	6
3 in. scale length	
All sizes	10
1 1/2 in. scale length	
All sizes	10

Process temperature limits

Non-certified systems

Stainless steel fittings: 0 to 120 °C
Brass fittings: 0 to 95 °C

ATEX Certified systems

Option/Temp Class	Max permissible process temperature in °C		
	T6	T5	T4
A6xxx without ring sensors	75	90	120
A6xxx with ring sensors	40	40	40

Ambient temperature limits

A6xxx without ring sensors: 0 to 60 °C
A6xxx with ring sensors: 0 to 40 °C

Types of installation

In-line, front- & rear-panel-mounting
Wall-mounting (regulator only)

Permissible operating pressures – kPa (bar)

Scale length (in.)	Material			
	Stainless steel		Brass	
	Fluid Temperature		Fluid Temperature	
	Max.	Design	Max.	Design
	120 °C (248 °F)	38 °C (100 °F)	95 °C (203 °F)	38 °C (100 °F)
1 1/2 to 3	1800 (18)	1800 (18)	1400 (14)	1800 (18)
5 to 10	1800 (18)	1800 (18)	1400 (14)	1800 (18)

Materials

Wetted Parts	Standard	Options
Measuring Tube	Borosilicate glass	–
Float	1/16 in. Glass (BG) Sapphire (SA) 316 Stainless Steel	Carboloy (CA) Tantalum (TA)
	1/8 in. Glass (BG) Sapphire (SA) 316 Stainless Steel	Carboloy (CA) Tantalum (TA)
	1/4 in. Glass (CD) 316 Stainless Steel	Sapphire (SA) Carboloy (CA) Tantalum (TA)
Float Stop	5 in. tube PTFE 3 & 1 1/2 in. tube 316 Stainless Steel	316 Stainless Steel
Fittings	Brass 316 S31 Stainless Steel	
DP Regulator	Brass 316 S31 Stainless Steel	–
O-rings	Buna N Viton A	Ethylenepropylene Kalrez
Tube Adapter	Brass 316 Stainless Steel	–
Needle Valve	316 S31 Stainless Steel	–
Non-return Ball	PTFE	–

Other components

Body	304 Stainless Steel
Operator Protection Shield	Polycarbonate

Connections

1/4 in. NPT or G1/4 internal thread, horizontal (rear facing) or vertical

Weights

	Without Regulator (kg)	With Regulator (kg)
Model A6131/41	0.45	1.6
Model A6132/42	0.65	1.8
Model A6133/43	0.80	2.0
Model A6134/44	0.45	1.6
Model A6135/45	0.45	1.6

Measuring Ranges – Models A6131/41

Measuring Tube	Float	Water		Air 0 °C 1013 mbar (cm ³ /min) (Q _n)		Min. diff. press. bar ^a	Alarm RC10 = 1 RC15 = 2	Measuring Tube/Float Combination ^c
		cm ³ /min	l/h	Q _n (cm ³ /min)	Q _n (l/h)			
FP-1/8-08-P-3/37	BG-18	0.4 to 4.4	0.02 to 0.26	20 to 360*	2 to 21	0.17	–	F1
	SA-18	0.5 to 8.5	0.04 to 0.5	20 to 500	2 to 30	0.18	–	F5
	SS-18	1 to 19*	0.1 to 1.1	50 to 850*	3 to 50	0.18	1	F6
	CA-18	2 to 34	0.1 to 2.0	50 to 1300	5 to 80	0.18	1	F2
FP-1/8-20-P-3/37	BG-18	2 to 28	0.1 to 1.7	100 to 1500	5 to 95*	0.21	–	F8
	SA-18	4 to 48*	0.2 to 2.9	200 to 2000	10 to 125	0.21	–	G1
	SS-18	5 to 90*	0.4 to 5.4*	200 to 3000*	10 to 180	0.21	1	G2
	CA-18	10 to 135	0.5 to 8.0	400 to 4000	20 to 260	0.21	1	F9
	TA-18	15 to 145	1 to 8.5	460 to 4600	27 to 270	0.21	–	H1
FP-1/4-15-P-3/37	CD-14	10 to 130	0.5 to 7.5	500 to 6500	20 to 380	0.35	–	N0
	SA-14	23 to 230	1.4 to 14	850 to 8500	52 to 520	0.35	–	N3
	SS-14	20 to 400	2 to 23.0	1000 to 12500	50 to 750	0.7	2	N6
	CA-14	40 to 580	2 to 34.0	1000 to 17000	100 to 1050	0.7	2	M3
FP-1/4-20-P-3/37	CD-14	20 to 220*	0.5 to 13.0*	500 to 9500	40 to 560	0.35	–	M4
	SA-14	40 to 400	2 to 22	1000 to 12500	70 to 750	0.35	–	M5
	SS-14	40 to 580*	2.0 to 34.0*	1000 to 18000	100 to 1100	0.7	2	M6
	CA-14	50 to 850	4 to 50.0	2000 to 25000	100 to 1500	0.7	2	N1
FP-1/4-41-G-3/37	CD-14	40 to 460	2 to 27.0	1000 to 19000	100 to 1150	0.7	–	N2
	SA-14	70 to 750	4 to 46	3000 to 27000	200 to 1600	0.7	–	N5
	SS-14	100 to 1200	5 to 75.0*	2000 to 38000	100 to 2300	0.7	2	N8
	CA-14 ^b	100 to 1800	10 to 105	4000 to 54000	200 to 3200	–	2	M9

Notes.

- a) Applies only with differential pressure regulator
 - b) Not available with differential pressure regulator
 - c) For ordering information only
- * Direct reading scales as standard

Measuring Ranges – Models A6131/41 with Inductive Alarm Sensor (RC10/RC15)

Measuring Tube	Float	Water cm ³ /min	Air 0 °C 1013 mbar (cm ³ /min) (Q _n)	Minimum Differential Pressure (bar) ^a	Ring Sensor
FP-1/8-08-P-3/37	SS-18	2 to 19	100 to 850	0.18	RC10-14-N3-Y115614
FP-1/8-20-P-3/37	SS-18	10 to 90	400 to 3200	0.21	
FP-1/4-15-P-3/37	SS-14	40 to 400	1000 to 12500	0.7	RC15-14-N3-Y115615
	CA-14	80 to 580	2000 to 17000	1.5	
FP-1/4-20-P-3/37	SS-14	80 to 580	2000 to 18000	0.7	
	CA-14	100 to 850	4000 to 25000	1.5	
FP-1/4-41-G-3/37	SS-14	150 to 1200	6000 to 40000	0.7	
	CA-14	200 to 1800	8000 to 54000	Note ^b	

Notes.

- a) In conjunction with differential pressure regulator
- b) Not available with differential pressure regulator

Measuring Ranges – Models A6132/42

Measuring Tube Size	Measuring Tube No.	Float No.	Max. flow ^a		Alarm RC10 = 1 RC15 = 2	Float/ Measuring Tube Combination ^c	
			Water cm ³ /min	Air 0 °C 1013 mbar (cm ³ /min) (Q _v)			
1/16 in. ^b	FP-1/16-12-G-5/81 16 20	BG-16	0.92 1.61 2.45	80.0 131.1 192.5		B6 C1 C6	
	FP-1/16-12-G-5/81 16 20	SA-16	1.58 3.2 4.82	117.0 188.6 270.1		B8 C3 C8	
	FP-1/16-12-G-5/81 16 20	SS-16	4.2 7.2 10.3	103.5 319.2 430.5		B9 C4 C9	
	FP-1/16-12-G-5/81 16 20	CA-16	7.6 12.3 17.8	307.1 475.3 636.2		B7 C2 C7	
	FP-1/16-12-G-5/81 16 20	TA-16	8.4 13.5 18.6	326.7 508.5 678.0		C0 C5 D0	
1/8 in.	FP-1/8-08-G-5/81 12 16 20 25	BG-18	6.1 13.9 22.6 31.5 43.7	373.6 696.3 1046.2 1426.6 1885.1		H2 H7 J2 J7 K2	
	FP-1/8-08-G-5/81 12 16 20 25	SA-18	10.5 23.0 35.7 48.5 64.5	511.3 928.8 1384.7 1857.6 2454.0		H4 H0 J4 J9 K4	
	FP-1/8-08-G-5/81 12 16 20 25	SS-18	20.5 39.5 60.0 81.0 107.0	804.4 1421.4 2092.8 2788.3 3629.1	1 1 1 1 1	H5 J0 J5 K0 K5	
	FP-1/8-08-G-5/81 12 16 20 25	CA-18	33.6 61.2 90.6 121.7 159.7	1205.7 2089.4 3014.3 3997.8 5136.7	1 1 1 1 1	H3 H8 J3 J8 K3	
	FP-1/8-08-G-5/81 12 16 20 25	TA-18	36.5 66.0 97.5 130.0 171.5	1287.9 2219.0 3202.4 4229.3 5456.3		H6 J1 J6 K1 L1	
	1/4 in.	FP-1/4-10-G-5/81 16 20 25	CD-14	78 152 206 275	3717 6742 8928 11479		R4 S0 S6 T2
		FP-1/4-10-G-5/81 16 20 25	SA-14	134 253 337 446	5200 9245 12231 15650		R5 S1 S7 T3
		FP-1/4-10-G-5/81 16 20 25	SS-14	228 415 547 703	7793 13672 17979 22900	2 2 2 2	R6 S2 S8 T4
		FP-1/4-10-G-5/81 16 20 25	CA-14	346 612 805 1036	10967 19227 25293 32200	2 2 2 2	R3 R9 S5 T1
		FP-1/4-10-G-5/81 16 20 25	TA-14	370 660 860 1105	11704 20457 26703 34276		R7 S3 S9 T5
		FP-1/4-40-G-6/81 FP-1/4-40-G-6/81 FP-1/4-40-G-6/81	SS-14 CA-14 TA-14	1500 2050 2200	45700 64800 67200	2 2	V0 T7 W1

Notes.

- a) Maximum flow rates for other fluids can be calculated using our sizing software – contact ABB
- b) Not available with differential pressure regulator
- c) For ordering information only

Measuring Ranges – Models A6132/42 with Inductive Alarm Sensor (RC10/RC15)

Measuring Tube	Float	Max. Flow		Minimum Differential Pressure (bar) ^a	Ring Sensor
		Water cm ³ /min	Air 0 °C 1013 mbar (cm ³ /min) (Q _n)		
FP-1/8-08-G-5/81 12 16 20 25	SS-18	20.5 39.5 60.0 81.0 107.0	804.4 1421.4 2092.8 2788.3 3629.1	0.18	RC10-14-N3-Y115614
FP-1/4-10-G-5/81 16 20 25	SS-14	228 415 547 703	7793 13672 17979 22900	0.7	
FP-1/4-10-G-5/81 16 20 25	CA-14	346 612 805 1036	10967 19227 25293 32200	1.5	RC15-14-N3-Y115615
FP-1/4-40-G-6/281 40	SS-14 CA-14	1512 2180	48384 67580	0.7 ^b	

Notes.

- a) In conjunction with differential pressure regulator
- b) Not available with differential pressure regulator

Measuring Ranges – Models A6133/43

Measuring Tube	Float	Max. Flow			
		Water		Air 0 °C 1013 mbar	
		cm ³ /min	l/h	cm ³ /min (Qn)	l/h
FP-1/8-077-G-10	SA-18	1 to 9.5	0.08 to 0.58	80 to 520	4 to 32
FP-1/8-13.3-G-10	BG-18	2 to 17	0.1 to 1.0	100 to 850	6 to 50
FP-1/8-077-G-10	SS-18	2 to 20	0.15 to 1.2	100 to 800	6 to 50
FP-1/8-13.3-G-10	SA-18	2 to 27	0.2 to 1.6	150 to 1100	10 to 65
FP-1/8-13.3-G-10	SS-18	6 to 48	0.2 to 2.9	200 to 1700	10 to 100
FP-1/4-10-G-10	BG-14	10 to 95	0.8 to 5.6	400 to 4200	20 to 250
FP-1/4-19-G-10	BG-14	20 to 230	1.5 to 13.5	1000 to 9000	80 to 560
FP-1/4-10-G-10	CA-14	40 to 360	2 to 22	1500 to 11500	100 to 700
FP-1/4-19-G-10	SS-14	80 to 540	4 to 32	2000 to 17000	150 to 1050
FP-1/4-40-G-10	BG-14	80 to 600	4 to 38	2000 to 26000	200 to 1600
FP-1/4-19-G-10	CA-14	100 to 800*	6 to 48	2000 to 24000	150 to 1450
FP-1/4-40-G-10	SS-14	150 to 1500*	10 to 90	6000 to 48000	200 to 2900
FP-1/4-40-G-10	CA-14	200 to 2200*	15 to 135	1000 to 70000	400 to 4000

*Not available with differential pressure regulator

Measuring Ranges – Models A6133/43 with Inductive Alarm Sensor (RC10/RC15)

Measuring Tube	Float	Max. Flow			
		Water		Air 0 ° C 1013 mbar	
		cm ³ /min	l/h	cm ³ /min (Qn)	l/h
FP- ¹ / ₈ -077-G-10	SS-18	2 to 20	0.15 to 1.2	100 to 800	6 to 50
FP- ¹ / ₈ -13.3-G-10	SS-18	6 to 48	0.2 to 2.9	200 to 1700	10 to 100
FP- ¹ / ₄ -10-G-10	CA-14	40 to 360	2 to 22	1500 to 11500	100 to 700
FP- ¹ / ₄ -19-G-10	SS-14	80 to 540	4 to 32	2000 to 17000	150 to 1050
FP- ¹ / ₄ -19-G-10	CA-14	100 to 800*	6 to 48	2000 to 24000	150 to 1450
FP- ¹ / ₄ -40-G-10	SS-14	150 to 1500*	10 to 90	6000 to 48000	200 to 2900
FP- ¹ / ₄ -40-G-10	CA-14	200 to 2200*	15 to 135	1000 to 70000	400 to 4000

*Not available with differential pressure regulator

Measuring Ranges – Models A6134/44

Measuring Tube ^b	Float No.	Water cm ³ /min	Air 0 ° C 1013 mbar (cm ³ /min) (Q _n)	Min. Required Differential Press bar ^a	Float/ Measuring Tube Combination ^d
Tube No.					
FP- ¹ / ₁₆ -08-P-1 ¹ / ₂ /19	BG-16 ^c	0.05 to 0.8	5 to 65	–	A1
	SA-16 ^c	0.10 to 1.0	5 to 90	–	A2
	SS-16 ^c	0.50 to 4.0	15 to 170	–	A3
FP- ¹ / ₁₆ -30-P-1 ¹ / ₂ /19	BG-16	0.5 to 7.0	25 to 400	0.17	A4
	SA-16	1.0 to 13.0	50 to 550	0.17	A5
	SS-16	2.0 to 22.0	50 to 850	0.17	A6
FP- ¹ / ₈ -21-P-1 ¹ / ₂ /19	BG-18	2.5 to 37.5	100 to 2000	0.21	E1
	SA-18	5.0 to 60.0	200 to 2600	0.21	E3
	SS-18	10 to 120.0	200 to 3800	0.21	E4
	CA-18	14 to 180	280 to 5600	0.21	E2
FP- ⁵ / ₃₂ -40-P-1 ¹ / ₂ /19	BG- ⁵ / ₃₂	15 to 190	700 to 8000	0.18	W2
	SS- ⁵ / ₃₂	40 to 450	1200 to 15000	0.18	W3
FP- ¹ / ₄ -28-P-1 ¹ / ₂ /19	SA-14	30 to 570	1300 to 19500	0.7	L2
	SS-14	50 to 850	2000 to 28000	0.7	L3
FP- ¹ / ₄ -41-P-1 ¹ / ₂ /19	SS-14 ^c	100 to 1600	2500 to 45000	–	M1
	CA-14 ^c	200 to 2200	5000 to 70000	–	L4

Notes.

- Applies only with built-in differential pressure regulator
- Only with % scale. Not available with differential pressure regulator.
- Not available with differential pressure regulator.
- For ordering information only.

Overall Dimensions

In-line and Front Panel-mounting (horizontal and vertical connections)

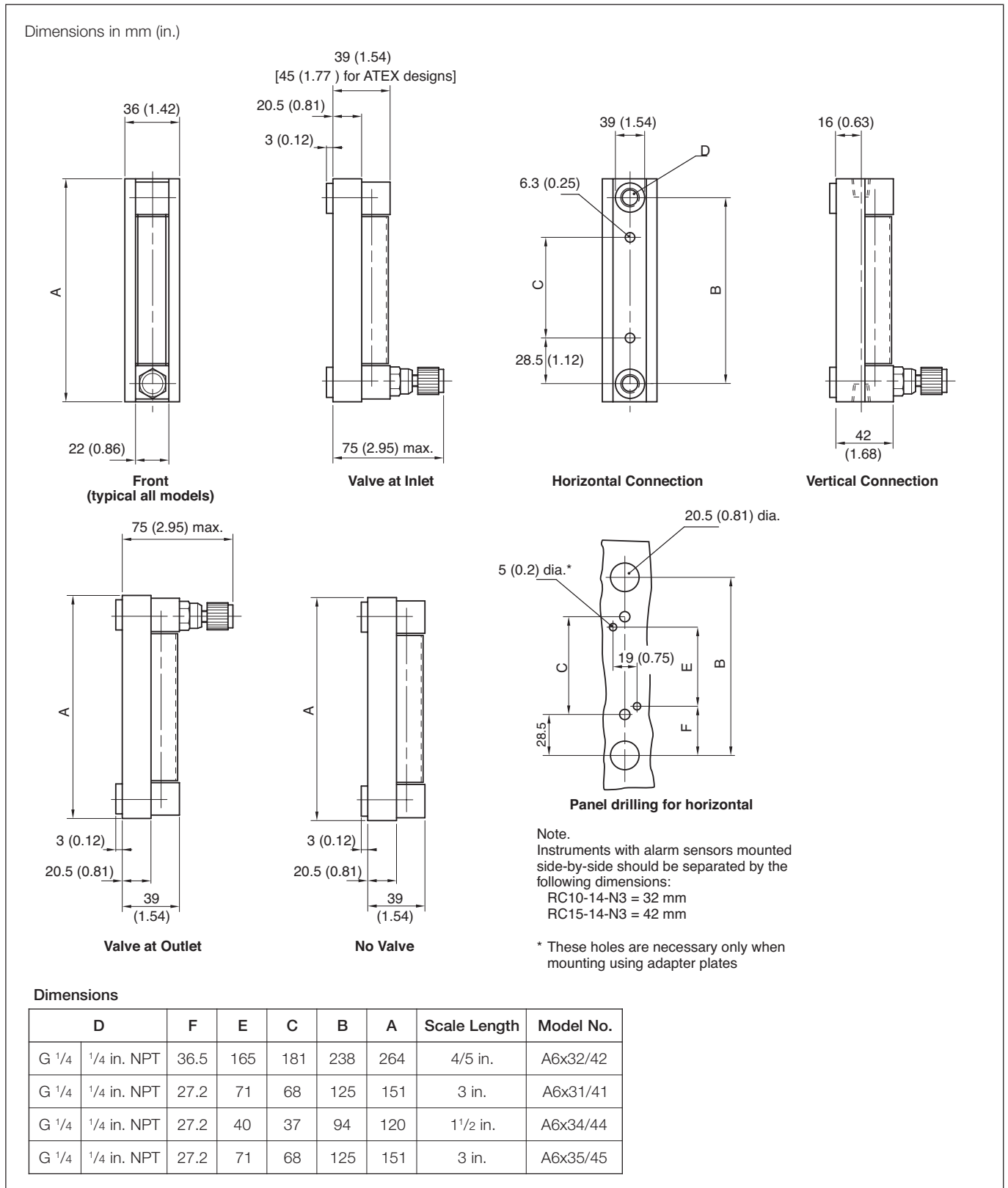

Purgemaster with Regulator

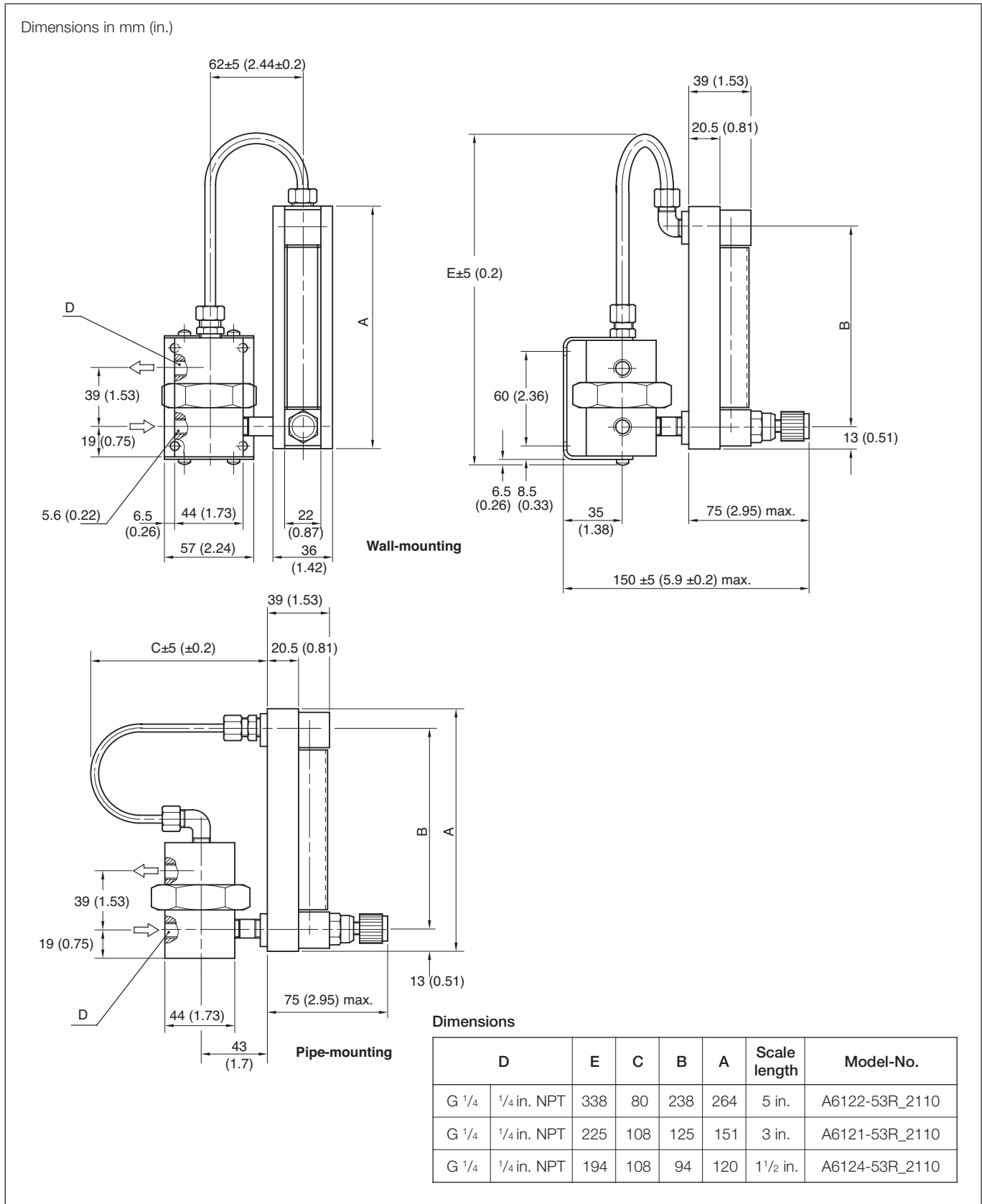

Panel-mounting (horizontal connections)

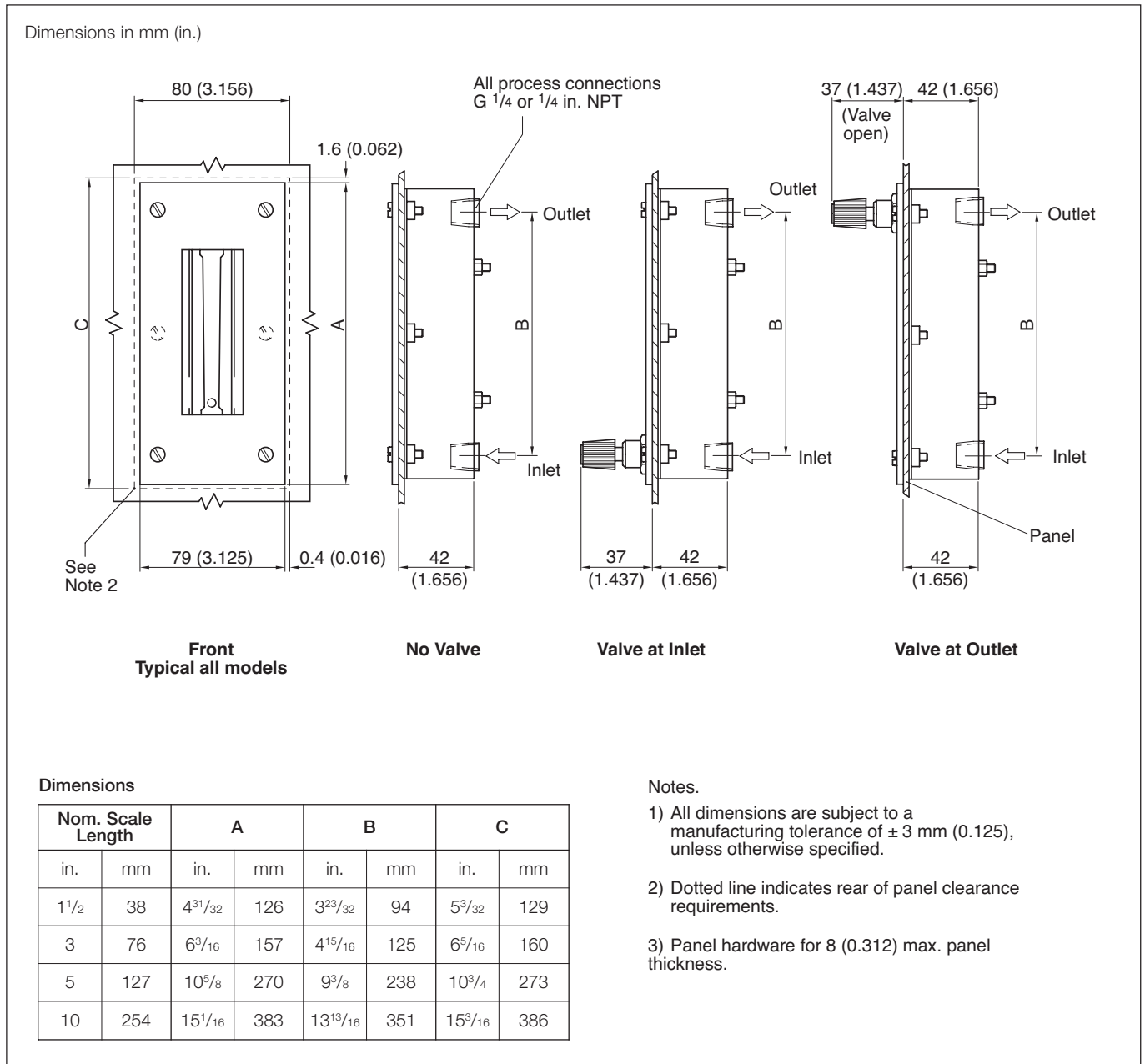

Panel-mounting with Differential Pressure Regulator

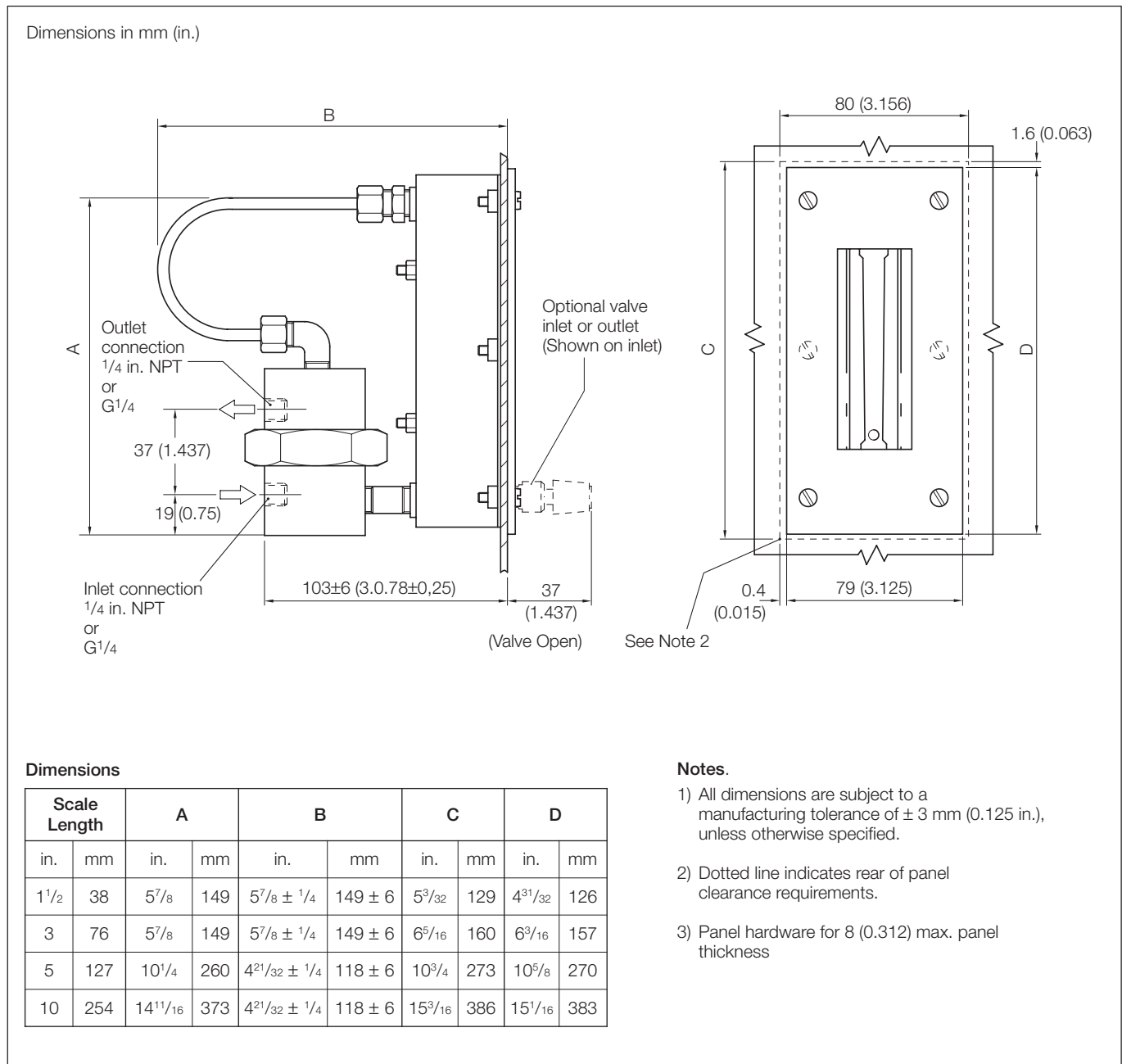

Panel Cut-out for Panel-mounting

Dimensions in mm (in.)

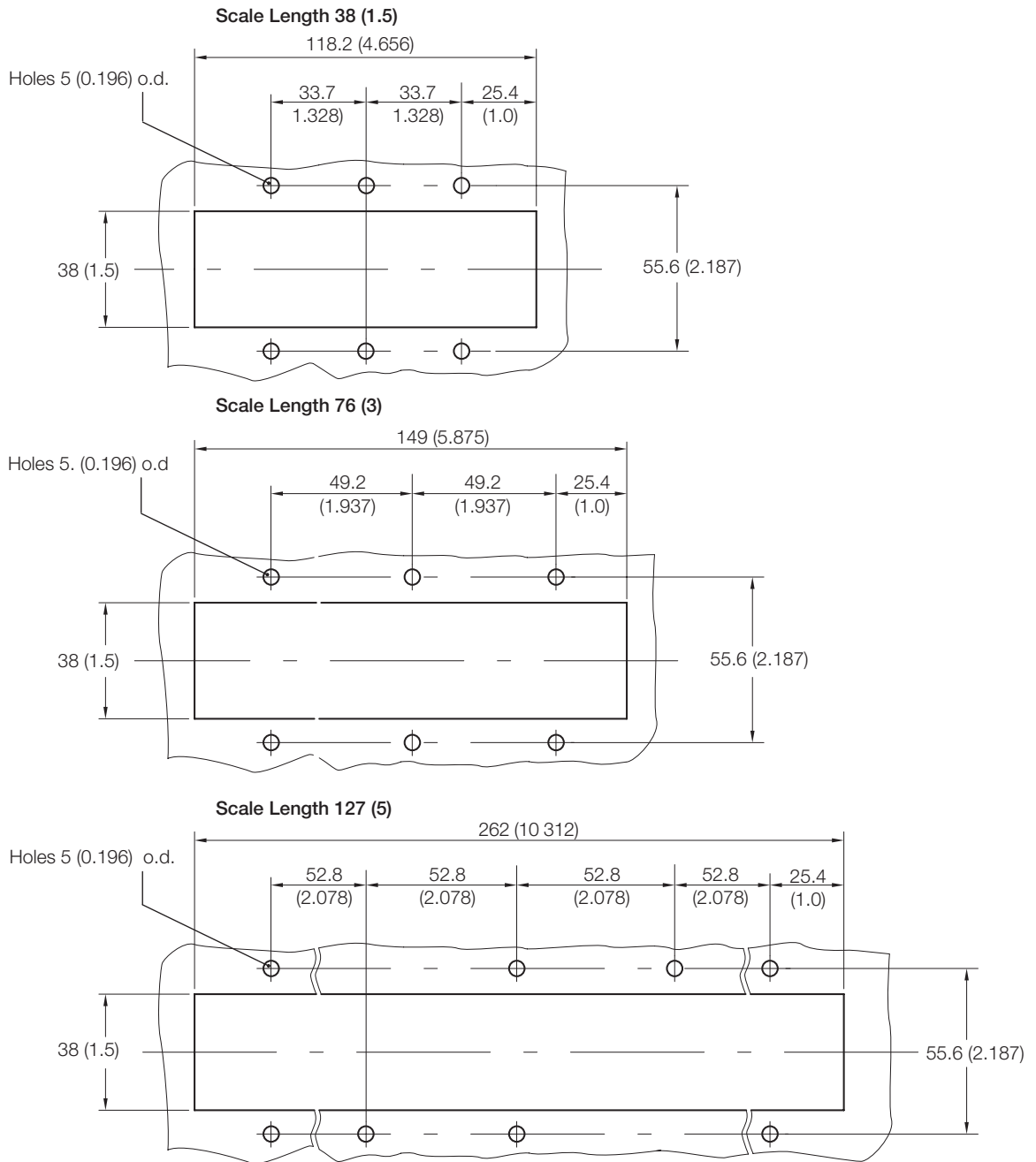

Ordering Information

Model Code	A6	X	X	X	X	X	X	X	X	X	X	X	X	X	X	X	X	X
Connection																		
Horizontal	1																	
Vertical	2																	
Connection Type																		
As regulator	2																	
1/4 in. NTP	3																	
G1/4	4																	
Tube 6 mm	5																	
Tube 8 mm	6																	
Hoses 6 mm	7																	
Hoses 8 mm	8																	
Special	9																	
Tube Length																		
3 in.	1																	
5 in.	2																	
10 in.	3																	
1 1/2 in.	4																	
Tube Diameter																		
1/16 in.	A																	
1/8 in.	B																	
1/4 in.	C																	
5/32 in.	D																	
Tube / Float																		
None	O O																	
Select from Tables on pages 3, 4 or 5	* *																	
Scale Type pages 3, 4, 5 or 6																		
Without	0																	
Direct reading	1																	
dt/df ratio	2																	
Percent	3																	
Standard direct reading	4																	
Calibrated	5																	
Materials																		
Brass / Viton	A																Stainless steel / Buna	J
Brass / Buna	B																Stainless steel / Ethylenepropylene	K
Brass / Ethylenepropylene	C																Stainless steel / Kalrez	L
Brass / Kalrez	D																Special	Z
Stainless steel / Viton	I																	
Valve																		
Without Valve	A																DVGW Valve at Outlet, Low Capacity (Size 1.2)	S
Valve at Outlet, Low Capacity (Size 1.2)	C																DVGW Valve at Outlet, Medium Capacity (Size 2.2)	Q
Valve at Outlet, Medium Capacity (Size 2.2)	M																DVGW Valve at Outlet, High Capacity (Size 3.2)	U
Valve at Outlet, High Capacity (Size 3.2)	E																DVGW Valve at Inlet, Low Capacity (Size 1.2)	T
Valve at Inlet, Low Capacity (Size 1.2)	D																DVGW Valve at Inlet, Medium Capacity (Size 2.2)	R
Valve at Inlet, Medium Capacity (Size 2.2)	N																DVGW Valve at Inlet, High Capacity (Size 3.2)	V
Valve at Inlet, High Capacity (Size 3.2)	F																	
Alarm (excluding amplifier)																		
Without																		A
Min. alarm																		B
Max. alarm																		C
Min. & max. alarm																		D
Suitable for alarms (no sensors fitted)																		E
Regulator																		
Without																		0
Standard capacity 1/4 in. NTP																		1
Standard capacity G 1/4																		2
High capacity 1/4 in. NTP																		3
High capacity G 1/4																		4
Mounting																		
In-line																		A
Wall																		B
Rear panel																		C
Front panel																		D
Laboratory stand																		E
Front panel + adaptor																		F
Front panel + end cap																		G
Front panel + end cap + adaptor																		H
Design level																		A
Certification																		
ATEX II 2Gc T6 -T4 with Ring Sensor																		A
ATEX II 2GDc T4 130 °C without Ring Sensor																		D
None																		S

Alarm Unit for Purgemaster

The alarm comprises a ring sensor and associated switching amplifier, available as an accessory, for glass-tube type variable-area flowmeters, type A6x31/41 and A6x32/42.

Clamped directly to the body, the ring sensor is continuously adjustable across the overall metering range. The ring sensor can be used with all metal-float equipped flowmeters according to the capacity tables.

Principle of Operation

The ring sensor, with a bistable switching action, energizes the relay in the amplifier when the float reaches the trigger level. It remains in that position, even if the float continues to move towards the alarm zone, thus leaving the trigger level. The relay de-energizes as soon as the float crosses the trigger level from the opposite direction and moves back from the alarm zone into the normal operating range. The actual float position – above or below the trigger level – is indicated precisely.

Operation in a hazardous area is possible, since the ring sensor used is an intrinsically safe switch with an intrinsically safe circuit. Flowmeter Model A6x31/41 is suitable for use either as a minimum alarm or a maximum alarm, due to its short metering tube. Model A6x32/42 is recommended if both alarm operations are required.

Design Features

- Sensor height 14 mm, minimizes coverage of the scale
- Integrated clamp secures device directly to the meter body
No automatic adjustment during operation is possible

Specification – Ring Sensor

Part Nos.

Measuring tube 1/8 in. type RC10-14-N3-Y115614

Measuring tube 1/4 in. type RC15-14-N3-Y115615

Supply voltage

10 V DC

Operating range

In direction 1 – 2.9 mA

In direction 2 – 4.8 mA

Permissible resistance of control cable

≤ 100 Ω

Repeatability

1 % (T = constant)

Temperature drift

± 10 %

Permissible ambient temperature

0 to 40 °C (32 to 104 °F)

Permissible process temperature

0 to 40 °C (32 to 104 °F)

Connection cable

LIFYY x 0.14 mm²

Cable length

5 m (16.5 ft)

Housing

Black Polycarbonate

Protection type as per EN 60529

IP67

Certificate of conformity

Ring Sensor only:	PTB 99 ATEX 2128X II 2G EEx ia IIC T6
Flowmeter with Ring Sensor:	BASEEFA 03 ATEX 0424X II 2G EEx c T6 – T4
Flowmeter without Ring Sensor:	BASEEFA 03 ATEX 0424X II 2GD EEx c 130°C

Weight

40 g (1.4 oz.) approx.

Specification – Switching Amplifier

Switch amplifier

Amplifier	Supply Voltage	Channels
KFD2-SR2-Ex1.W	24 V DC	1
KFD2-SR2-Ex2.W	24 V DC	2
KFA5-SR2-Ex1.W	115 V AC	1
KFA5-SR2-Ex2.W	115 V AC	2
KFA6-SR2-Ex1.W	230 V AC	1
KFA6-SR2-Ex2.W	230 V AC	2

Protection class

IP20

Electrical connection

Terminals

Weight

0.15 kg (0.33 lb) approx.

Output

Relay with potential-free changeover contacts.

Switching capacity max. 2 A at 250 V AC

Power consumption

Max. 1 W

Permissible ambient temperature

-20 to +60 °C (-4 to 140 °F)

Ex protection

Circuits in Zone 0/1/2 – EEx II (I) G D [EEx ai] IIC

$U_o = 10.5 \text{ V}$

$I_o = 13 \text{ mA}$

$P_o = 34 \text{ mW}$

Certificate number

PTB 00 ATEX 2080

Electrical Connections

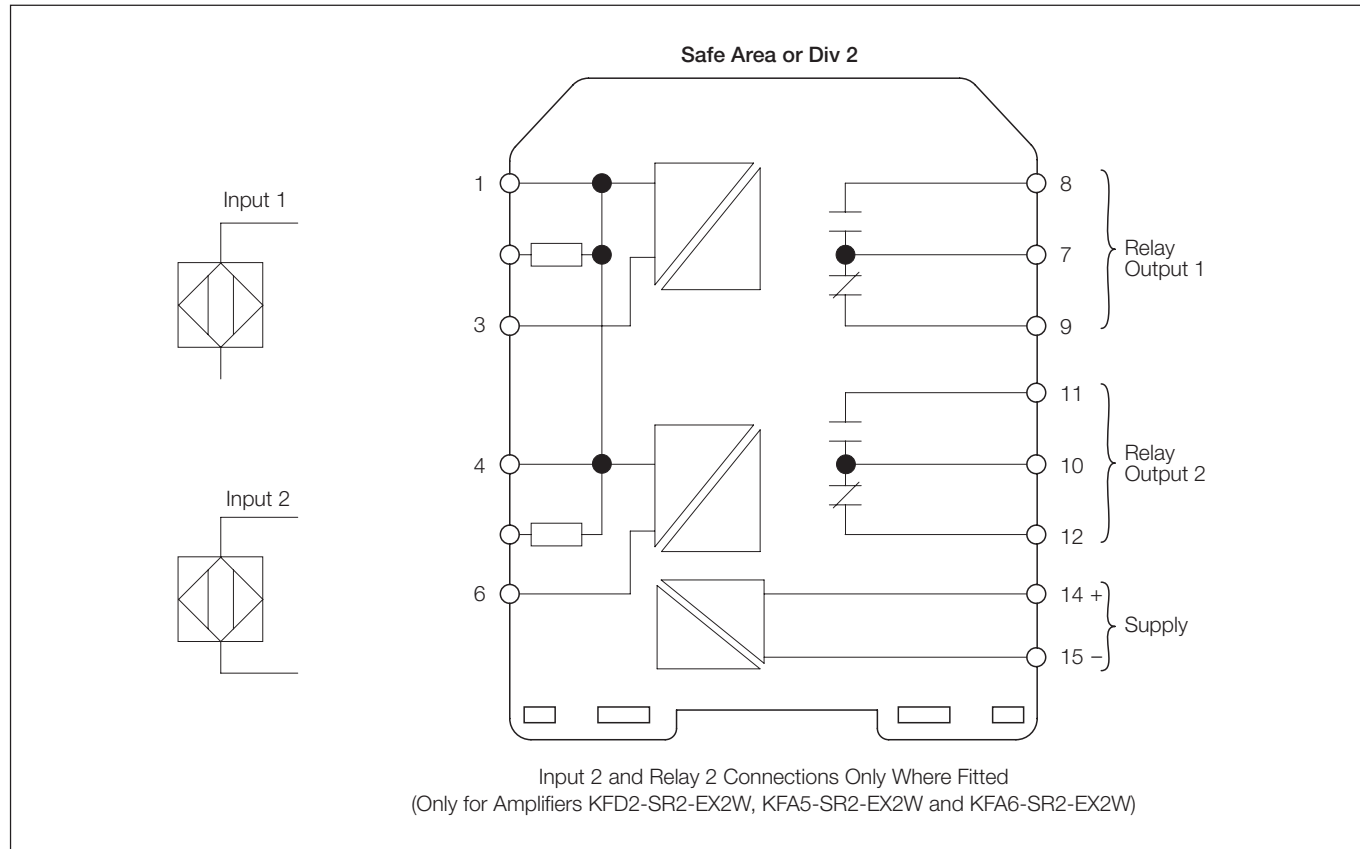

Electrical Connections

Overall Dimensions

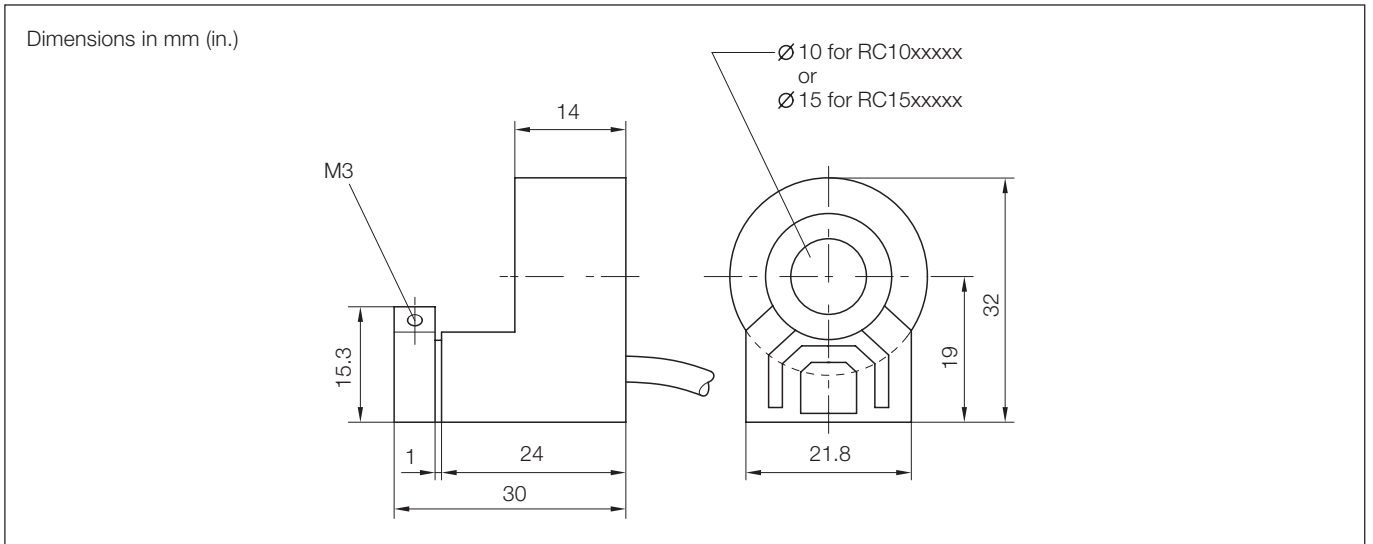

Ring Sensor

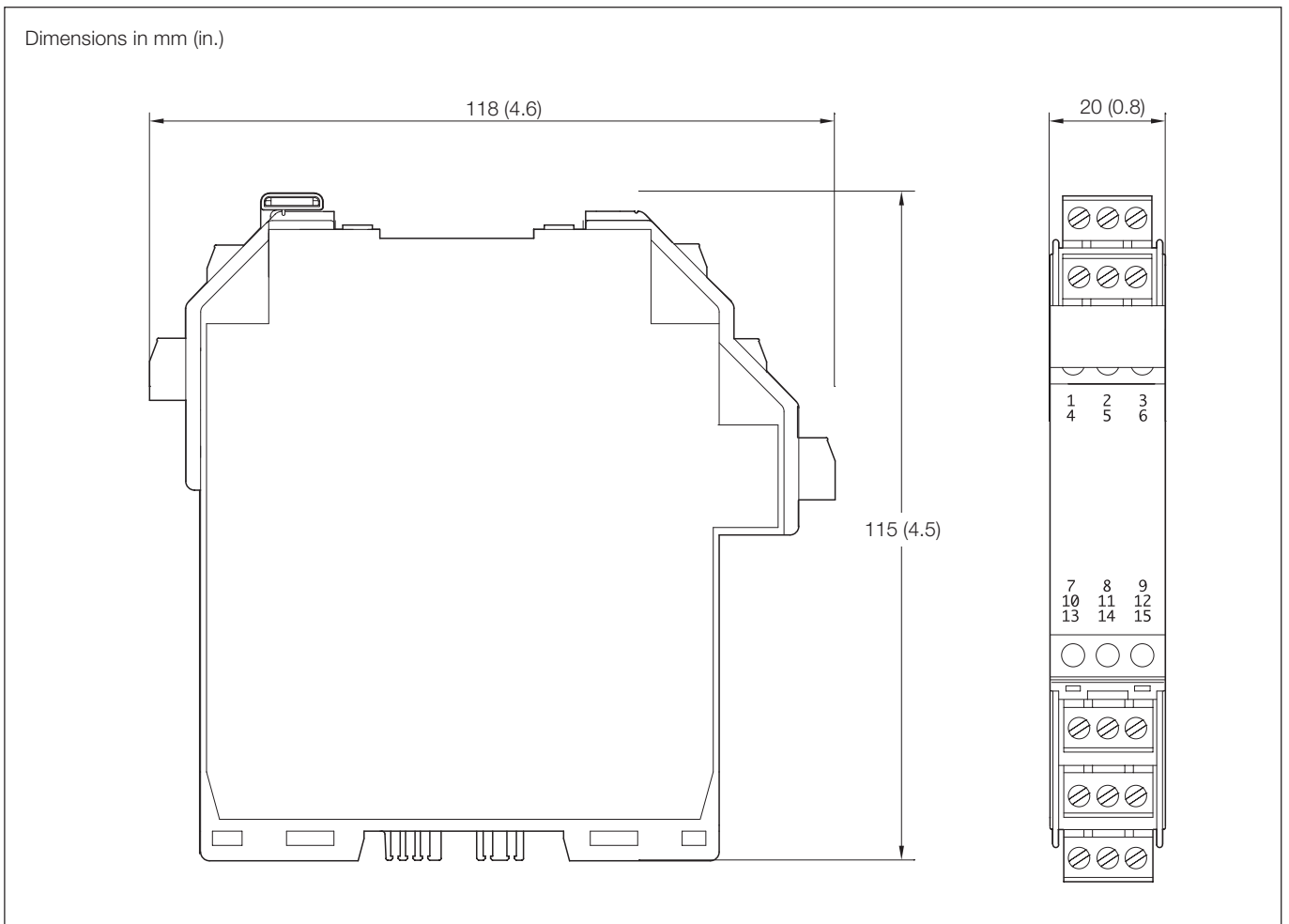

Switch Amplifier

Contact us

ABB Limited

Process Automation

Salterbeck Trading Estate
Workington, Cumbria
CA14 5DS
UK

Tel: +44 (0)1946 830 611

Fax: +44 (0)1946 832 661

ABB Inc.

Process Automation

125 E. County Line Road
Warminster
PA 18974
USA

Tel: +1 215 674 6000

Fax: +1 215 674 7183

www.abb.com

Note

We reserve the right to make technical changes or modify the contents of this document without prior notice. With regard to purchase orders, the agreed particulars shall prevail. ABB does not accept any responsibility whatsoever for potential errors or possible lack of information in this document.

We reserve all rights in this document and in the subject matter and illustrations contained therein. Any reproduction, disclosure to third parties or utilization of its contents in whole or in parts – is forbidden without prior written consent of ABB.

Copyright© 2016 ABB

All rights reserved

3KXF121501R1001













Sales



Service



Our offering:

	Actuators and Positioners		Analytical Instruments
	Device Management, Fieldbus and Wireless		Flow Measurement
	Force Measurement		Level Measurement
	Natural Gas Measurement		Pressure Measurement
	Recorders and Controllers		Temperature Measurement

HMI – Automação e Instrumentação, Lda.

Travessa da Indústria, nº 111
4780-573 Santo Tirso
PORTUGAL

Tel. +351 252 850 501
Fax. +351 300 013 487

Web: www.hmi.pt

Email: hmi@hmi.pt