



FICHA TÉCNICA DE PRODUTO

PRODUCT DATASHEET

HMI – Automação e Instrumentação, Lda.

Rua dos 5 Caminhos, nº 570
4780-382 Santo Tirso
PORTUGAL

Tel. +351 252 850 501
Fax. +351 300 013 487

Web: www.hmi.pt

Email: hmi@hmi.pt

4690 Series Turbidity systems

Accurate, reliable turbidity measurement



Flow-through turbidity design

- Fast response to process turbidity changes due to minimal sample residence time

Automatic sensor cleaning

- Reduces maintenance requirements
- Optimizes performance sensitivity

Secondary standards for calibration verification

- Accurate, repeatable, simple, safe
- Realize significant cost savings by reducing the use of primary standards

Reliable and accurate measurement

- Ultralow back scatter for accurate measurement of low turbidity values
- Automatic bubble rejection to compensate for erroneous readings due to degassing

4690 Series Turbidity systems

ABB's 4690 range of turbidity systems

The measurement of turbidity is a critical measurement in drinking water as it is used to indicate water quality and filtration effectiveness (for example, whether disease-causing organisms are present).

ABB's 4690 Range of turbidity systems have been designed specifically for the measurement of turbidity throughout the potable water treatment process.

Whichever of the two measurement ranges you choose, low range (0 to 40 NTU) or higher range (0 to 400 NTU), you can benefit from reliable, accurate turbidity measurement with automatic optical cleaning and dry standard calibration verification.

Applications

Typical applications for the 4690 range of flow-through turbidity systems in potable water treatment include:

- **Raw water / source monitoring**
Provides an indication of the solids loading entering the treatment plant to enable adjustment of the coagulant dose.
- **Monitoring clarified water**
Clarifier supernatant turbidity measurement monitors clarifier efficiency to provide early warning of floc blanket break-up or incorrect coagulant dosing.
- **Filter backwashing control**
Monitors the filter backwash curve to minimize clean water usage.
- **Monitoring of filtered water**
Ensures correct operation of the filters and guards against turbidity breakthrough.
- **Monitoring of final drinking water quality**
Provides a final quality check after disinfection before distribution.

For higher turbidity applications or for turbidity measurement in open channels and tanks please refer to ABB's 4670 range of turbidity systems (data sheet DS/4670-EN).

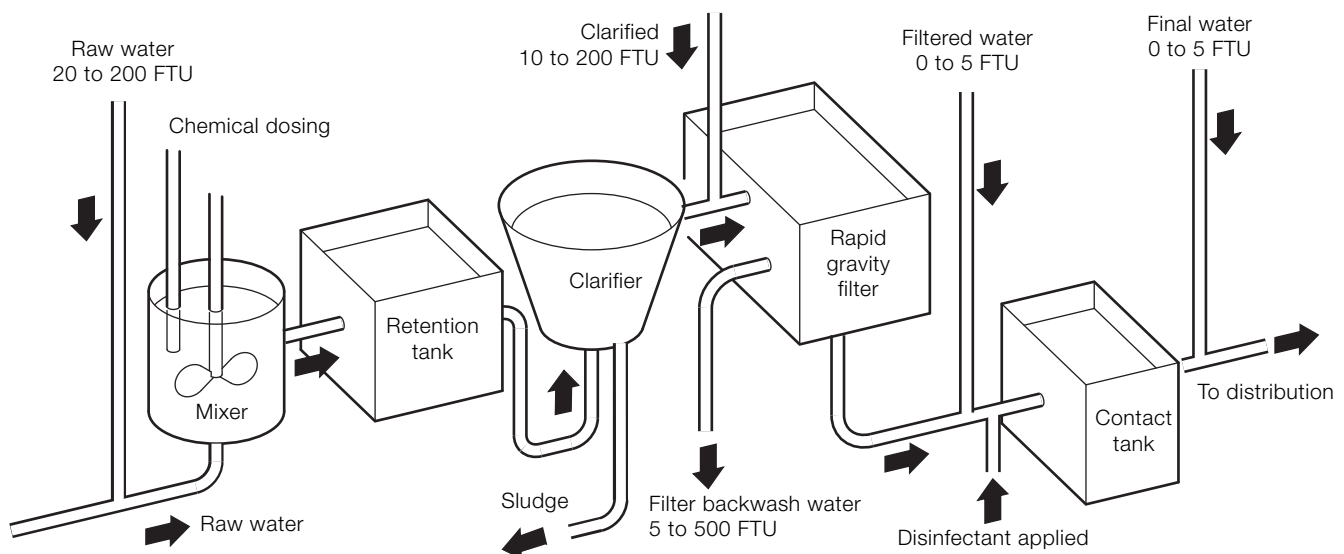
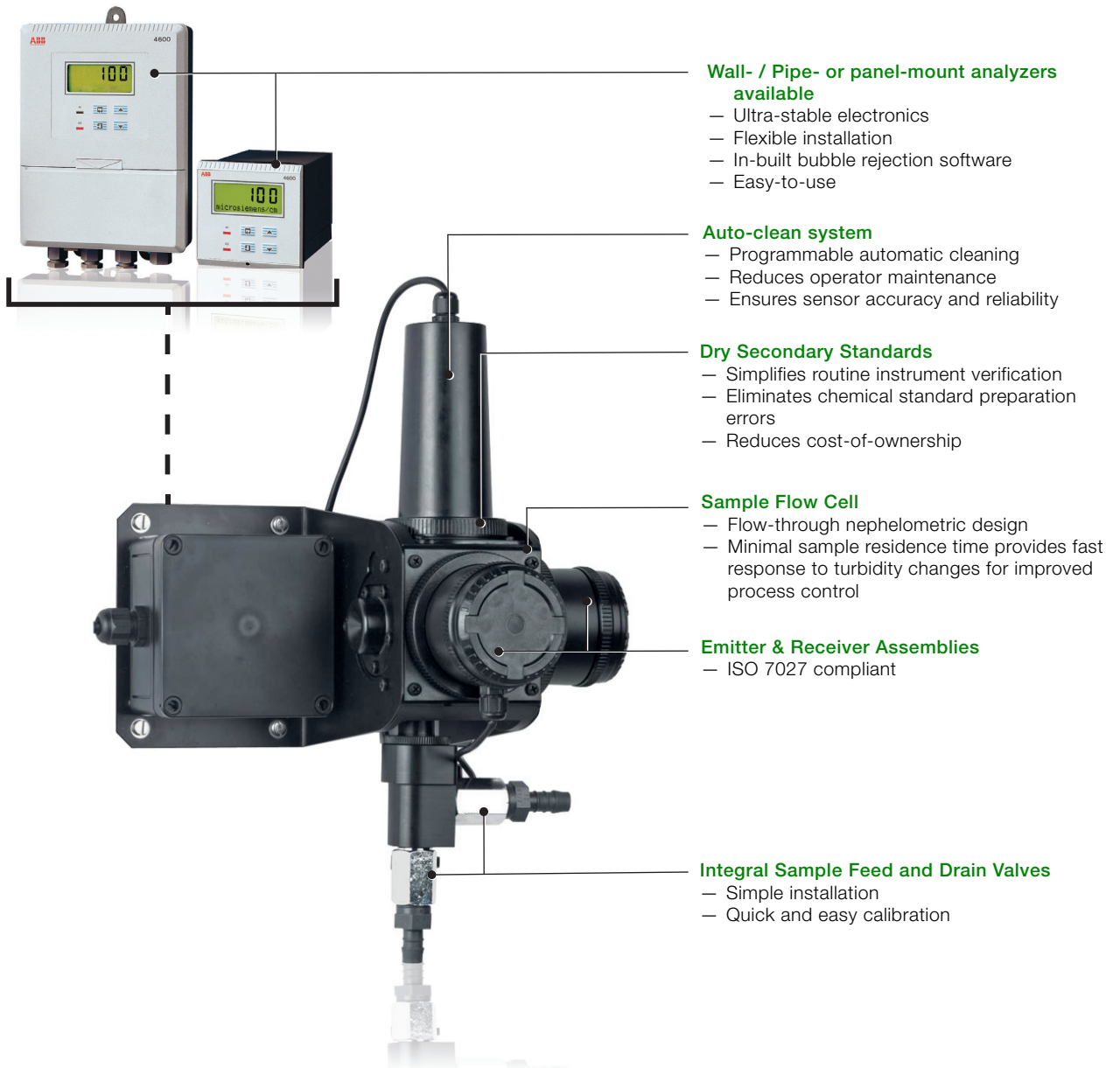

Fig. 1: Typical turbidity monitoring application

4690 turbidity system overview



Wall- / Pipe- or panel-mount analyzers available

- Ultra-stable electronics
- Flexible installation
- In-built bubble rejection software
- Easy-to-use

Auto-clean system

- Programmable automatic cleaning
- Reduces operator maintenance
- Ensures sensor accuracy and reliability

Dry Secondary Standards

- Simplifies routine instrument verification
- Eliminates chemical standard preparation errors
- Reduces cost-of-ownership

Sample Flow Cell

- Flow-through nephelometric design
- Minimal sample residence time provides fast response to turbidity changes for improved process control

Emitter & Receiver Assemblies

- ISO 7027 compliant

Integral Sample Feed and Drain Valves

- Simple installation
- Quick and easy calibration

4690 Series Turbidity systems

Reliable measurement

ABB's 4690 range of turbidity systems have been designed for reliability, ease-of-use and maintenance simplicity.

Measurement technique

The 4690 range of turbidity sensors utilize a flow-through nephelometric design compliant to the ISO* 7027 standard.

Water flows continually through the sensor body. Light directed by the emitter assembly passes through the sample where it is scattered by any suspended particles present in the sample. This scattered light is detected by the sensor receiver assembly that is placed at a 90° angle to the incident beam.

The ultralow back scatter allows for very accurate readings as only light scattering due to turbidity is measured. This is especially important when measuring low turbidity values. Due to the short sample residence time in the flow cell the system is able to respond much faster than many competing systems.

* International Organization for Standardization

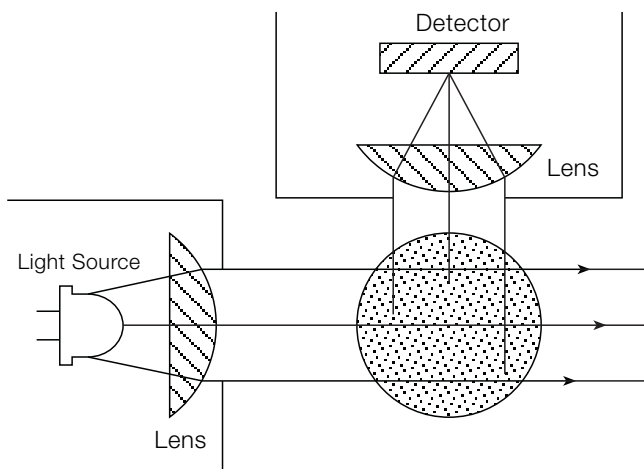

Fig. 2: Nephelometric turbidity monitor

Automatic cell cleaning

The 4690 range of turbidity sensors feature an auto-clean system. This feature consists of a mechanical wiper assembly that physically wipes clean the optical cell at user-programmable intervals from every 15 minutes up to every 24 hours.

The highly efficient automatic cleaning process overcomes the problem of optical fouling and ensures that performance can be maintained for long periods (up to 6 months) without the need for manual intervention.



Fig. 3: Auto-clean wiper unit

Automatic bubble rejection

Turbidity readings can be affected by short-term spikes, usually due to the effect of the sample degassing. The 4690 analyzer has an automatic bubble rejection feature that, when enabled, applies a digital filter to the measured results removing any spurious high reading.

Optional external debubbler

Any bubbles present in the sample give false turbidity readings. For applications where bubbles are likely, it is recommended that the optional external debubbler assembly is used to supply a constant head of debubbled sample to the sensor.

Simple to calibrate

A key feature of the 4690 turbidity systems is the dry secondary calibration standard that simplifies routine instrument verification and removes the need for the use of chemical standards.

Both low- and high-range secondary standards are available so that the analyzer calibration can be verified at a level that is suited to the application. Each secondary standard is supplied factory-certified against a primary formazine standard.



Fig. 4: Dry secondary standard

The benefits of using ABB's Secondary Standards include:

- **Minimum analyzer downtime**
Simple and fast procedure to verify analyzer performance.
- **Low cost of ownership**
Reduce usage of consumable chemical standards and the time taken to prepare such standards.
- **Minimise employee's exposure to Formazine**
Formazin is highly toxic and a suspected carcinogen.
- **Repeatable and reliable**
Removes any chemical standard preparation errors.
- **Simple to use**

The secondary standard is simply inserted into the sensor assembly optical light path allowing the pre-calibrated opto-mechanical filter to divert a fixed quantity of light to the detector that corresponds to the calibrated turbidity value. Rotation of the dry standard blocks the light path enabling a zero turbidity calibration to be made.



Fig. 5: Dry standard calibration

4690 Series Turbidity systems

Simple to maintain

The 4690 turbidity sensing systems are designed to be as maintenance-free as possible. The inherent product design and auto-clean feature minimize the amount of maintenance required to external cleaning of sample lines and periodic replacement of the wiper blade and light source.

The sensor features ABB's patented light replacement system, a unique feature that enables bulb replacement in the field in seconds. Each bulb is supplied fully protected in a patented assembly with integral light guide so you never come into direct contact with the bulb. This not only protects the bulb, ensuring maximum lamp life, but also makes replacement very simple and fast as it just clicks into place.



Fig. 6: Replacing the light source

Task	Recommended frequency
Visual checks – sample flow, leaks	Weekly
Calibration verification ¹ with secondary standard ² - as per regulatory guidelines	Monthly
Calibration ³ with primary standard ⁴ – as per regulatory guidelines	Quarterly
Replace wiper blade	Annually
Replace LED Light Source (ISO 7027)	Every 5 years

1. Calibration Verification

A procedure used to check whether or not the calibration of the analyzer is within certain limits.

2. Secondary Standards

Standards that the manufacturer (or an independent testing organization) has certified provide analyzer calibration results equivalent (within certain limits) to the results obtained when the instrument is calibrated with a primary standard.

3. Calibration

A procedure which checks or adjusts an analyzer's accuracy by comparison with a defined standard or reference.

4. Primary Standards

Turbidity standards that are traceable and equivalent to the reference turbidity standard, within statistical errors. Formazine is the most commonly acceptable form of primary standard. Primary standards are used to calibrate a turbidity meter directly or to calibrate a secondary standard.

4690 sensor specification

Range

Low range 0 to 40 NTU
High range 0 to 400 NTU

Measurement principle

90 ° scattered light measurement.
Compliant to ISO 7027

Maximum linearity

Typically <1.0 %

Accuracy^{1, 2}

Low range version ± 2 % of reading
High range version ± 5 % of reading or 0.3 NTU

Repeatability³

0 to 200 NTU: <1 %
200 to 400 NTU: 2 %

Limit of Detection⁴

Low range version: 0.003 NTU
High range version: 0.3 NTU

Response time

T90 < 1 min at 1 l/min⁻¹ (0.26 gall [US]/min⁻¹)

Flow rate

0.5 to 1.5 l/min (0.13 to 0.39 gall [US]/min)

Integral wiper cleaning system

Programmable operational frequency every 0.25 hour, 0.5 hour, 0.75 hour or multiples of 1 hour up to 24 hours

Sample operating temperature

0 to 50 °C (32 to 122 °F)

Sample pressure

Up to 3 bar (43.5 psi)

Ambient operating temperature

0 to 50 °C (32 to 122 °F)

Ambient operating humidity

Up to 95 % RH

Wetted parts – materials used

Cell body unit

- Black POM (Polyoxymethylene) Copolymer
- Spectrosil 2000 fused silica
- Nitrile (O-ring)
- Epoxy preform (cured): Uni-forms 5034-00
- Polyamide 6
- Nickel plated brass
- Teflon

Wiper unit

- Black Polycarbonate, 10% Glass Fibre filled – Lexan 500R
- Stainless Steel (SS 316 S13/S11) w/ Chemical Black – MIL-C13924 class 4
- Silicone grease (WRC Approved): Unisilkon L 250 L
- 2-part Epoxy Adhesive (cured): DELO AD894
- EPDM (ethylene propylene diene Monomer) black

¹Maximum measured error across full measurement range (typical, limited by uncertainty in Formazine standards).

²Tested in accordance with IEC 61298 Parts 1-4: Edition 2.0 2008-10.

³Tested in accordance with MCERTS: Performance Standards and Test Procedures for Continuous Water Monitoring Equipment. Version 3.1: Environment Agency 2010.

⁴Tested in accordance with BS ISO 15839: 2003.

4690 Series

Turbidity systems

4690 analyzer specification

General

Measured value

5-digit x 7-segment backlit LCD

Information

16-character, single line, dot matrix, backlit LCD

Units of measurement

All models: NTU and FNU

mg/l and ppm for high range models

Accuracy

±0.2 % of reading, ±1 digit

Linearity

±0.1 % FSD

Auto-clean timing (7998011, 7998012)

Programmable 15 min, 30 min, 45 min or 1 hour up to 24 hours in 1 hour increments

Environmental Data

Operating temperature limits

-20...55 °C (-4...131 °F)

Storage temperature limits

-25...55 °C (-13...131 °F)

Operating humidity limits

Up to 95 % RH non-condensing

Power Supply

Voltage requirements

100...130 V, 200...260 V, 50/60 Hz

Power consumption

< 6 VA AC

Error due to power supply variation

Less than 0.1 % for +6 % -20 % variation from nominal supply

Insulation

Mains to earth (line to ground) 2 kV RMS

Relay Outputs and Set Points

No. of relays

Two

Relay contacts

Single pole changeover

Rating 250 V AC 250 V DC max.

3 A AC, 3 A DC max.

Loading (non-inductive) 750 VA 30 W max.
(inductive) 750 VA 3 W max.

Insulation

2 kV RMS contacts to earth (ground)

No. of set points

Two

Set point adjustment

Programmable

Set point hysteresis

±1 % fixed

Local set point annunciation

Red LED

Retransmission

No. of retransmission signals

One fully isolated programmable 0...10 mA, 0...20 mA or 4...20 mA
Optional second current output

Accuracy

±0.25 % FSD ±0.5 % reading

Resolution

0.1 % at 10 A, 0.05 % at 20 mA

Max. load resistance

750 Ω (20 A max.)

Mechanical Data

Model 4690 Wall- / Pipe-mount transmitter

Wall-mounting

Protection IP66 / NEMA4X

Dimensions 160 mm (6.30 in.) wide x 214 mm (8.43 in.) high x
68 mm (2.68 in.) deep

Weight 2 kg (4½ lb)

Model 4695 Panel-mount transmitter

Panel-mounting (¼ DIN)

Protection IP66 / NEMA4X front

Dimensions 96 mm (3.78 in.) wide x 96 mm (3.78 in.) high x
191 mm (7.52 in.) deep

Weight 1.5 kg (3¼ lb)

Panel cut-out: $92^{+0.8}_{-0}$ mm x $92^{+0.8}_{-0}$ mm
($3.62^{+0.03}_{-0}$ in. x $3.62^{+0.03}_{-0}$ in.)

4690 Series Turbidity systems

Overall dimensions

4690 turbidity sensor (with optional wiper unit)

Dimensions in mm (in.)

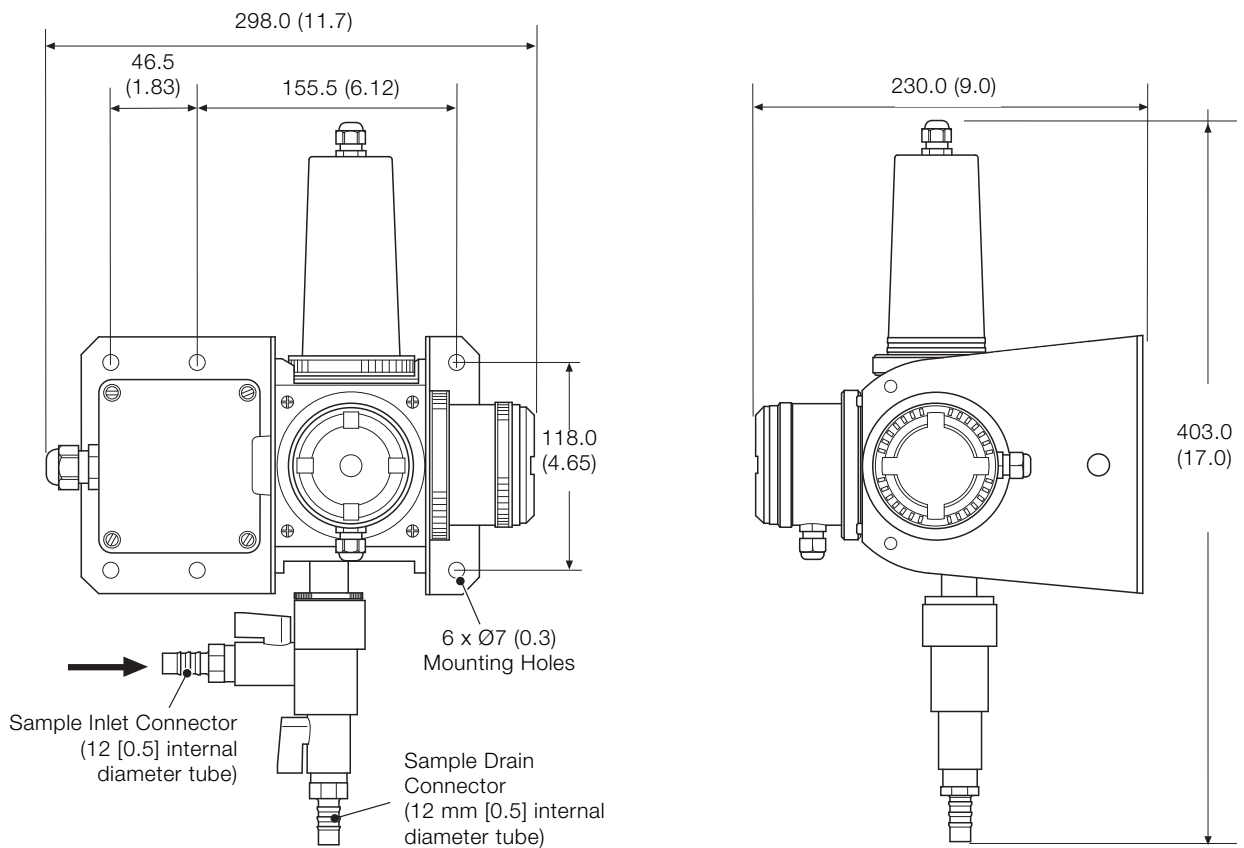

4690 turbidity sensor (without optional wiper unit)

Dimensions in mm (in.)

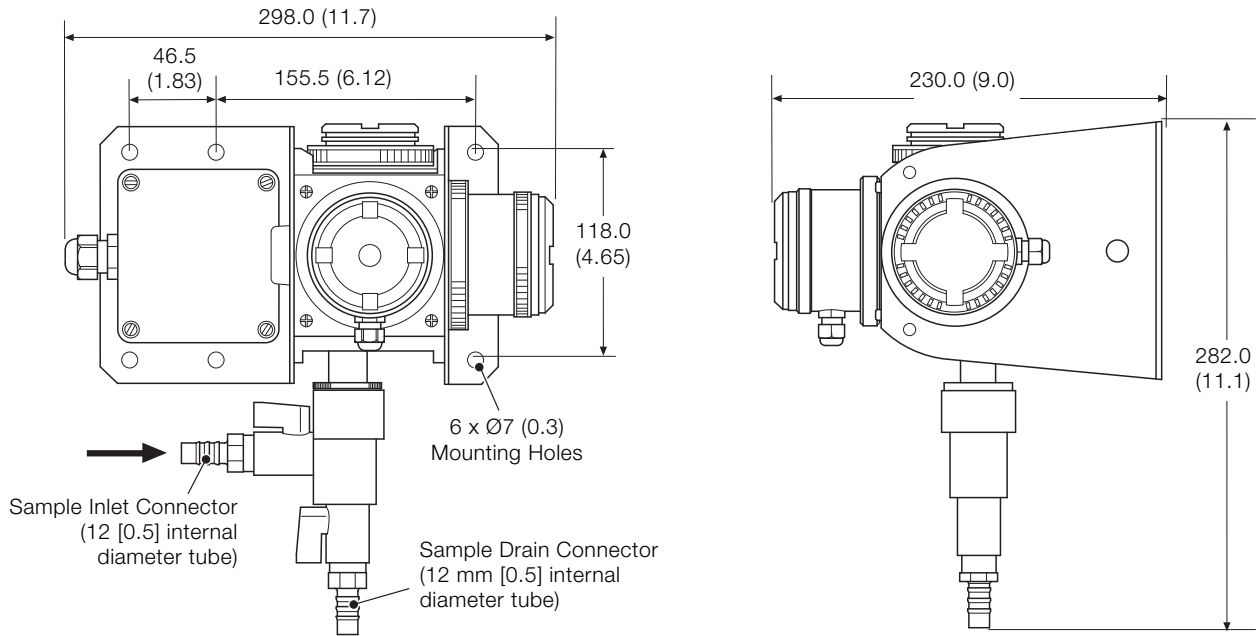

4690 Series Turbidity systems

4690 wall- / pipe-mount analyzer

Dimensions in mm (in.)

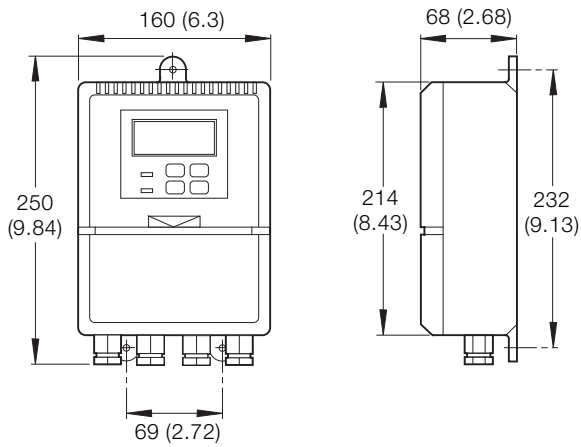

4695 panel-mount analyzer

Dimensions in mm (in.)

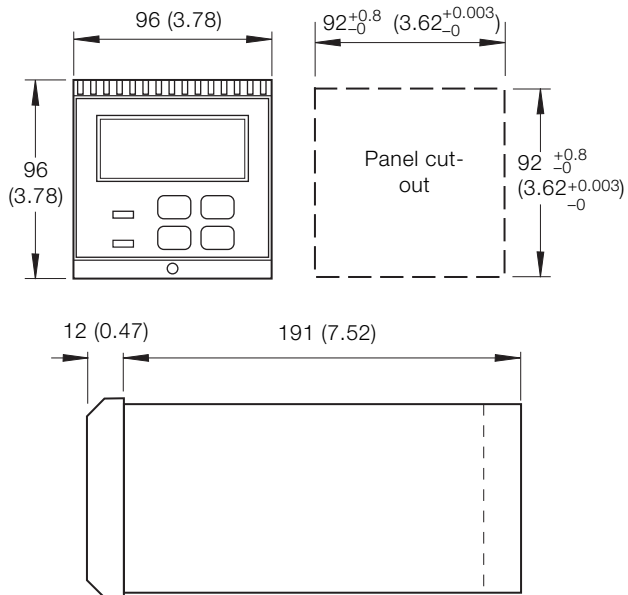

Optional de-bubbler assembly

Dimensions in mm (in.)

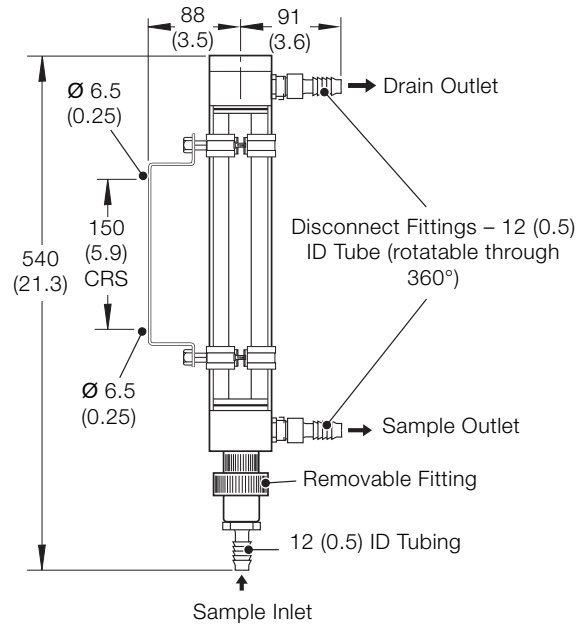

Electrical connections

Panel-mount analyzer connections

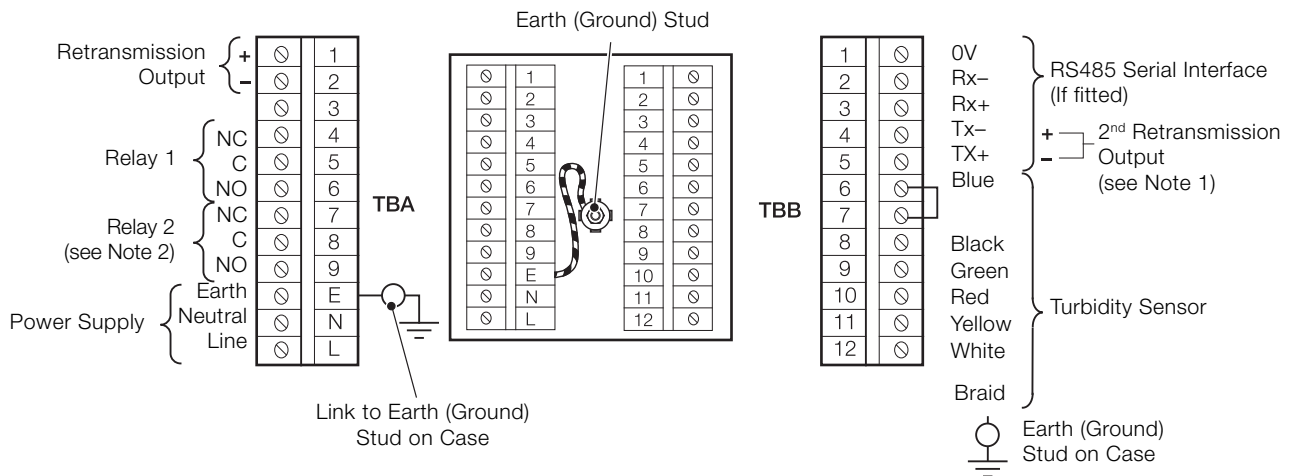

Wall- / Pipe-mount analyzer connections

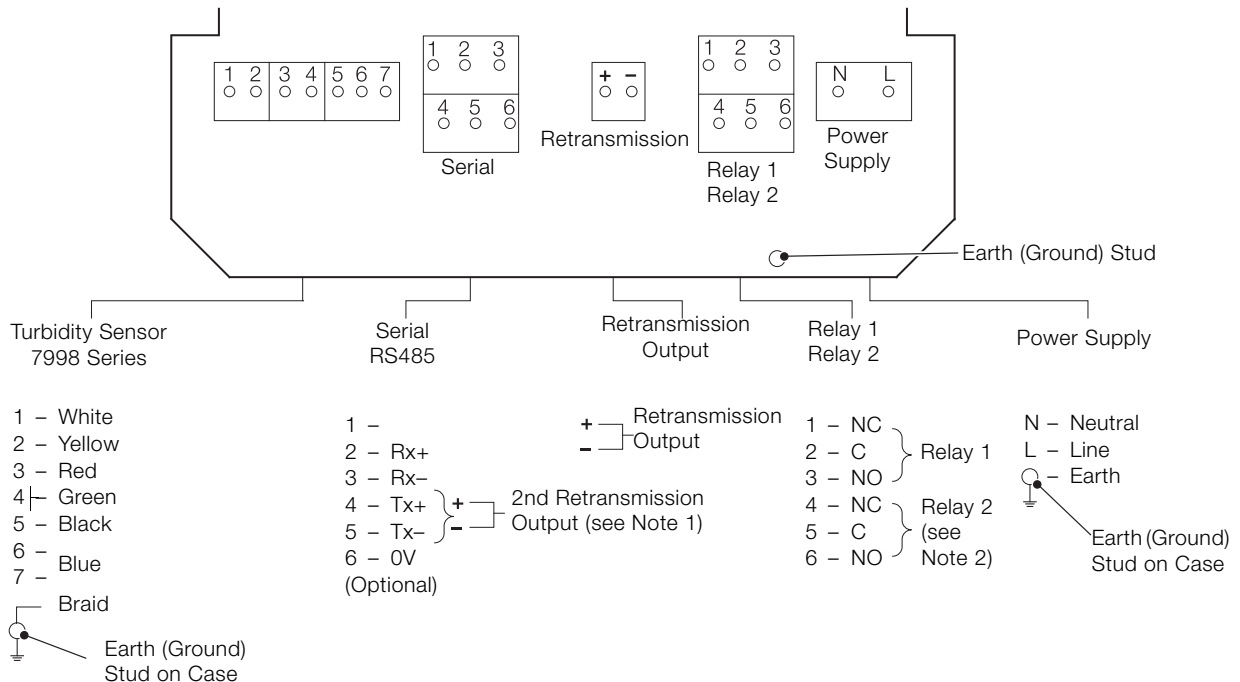

Note.

1. A second retransmission output is available if the RS485 serial communications facility is not used.
2. If 'Test Cleaner' is selected during analyzer configuration, Relay 2 becomes 'Failed Wiper Alarm' relay.

4690 Series Turbidity systems

Typical system installation schematic

With optional de-bubbler

Dimensions in mm (in)

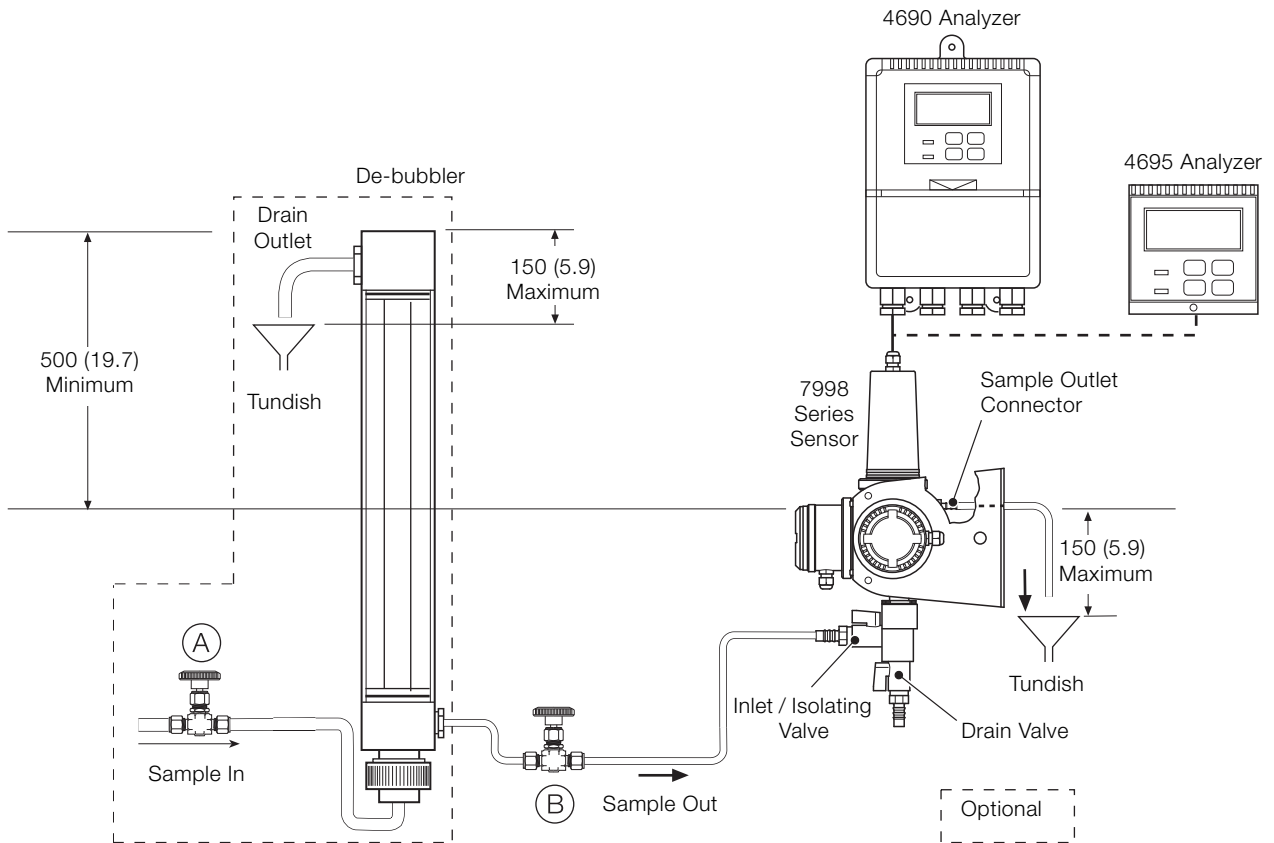

Ordering information







Turbidity system	4690/	X	X	X	X	X	X	X	X
Transmitter type									
Wall-/ Pipe-mount (gland fittings)	1								
Wall- / Pipe-mount (conduit)	2								
Panel-mount	5								
Voltage									
115 V AC			1						
230 V AC			2						
Communications and IO									
Standard (1 analog output)				1					
Additional analog output				2					
Modbus				3					
Sensor type									
Flow-through system (ISO 7027 compliant)					1				
Sensor range									
0 ... 40 NTU (without auto-clean)						1			
0 ... 40 NTU						2			
0 ... 400 NTU						3			
Secondary dry calibration									
Not included							0		
Low range (<5 NTU)							2		
High range (50 ... 100 NTU)							3		
Sensor cable length									
No sensor cable supplied								0	
1 m (3.3 ft)								1	
5 m (16.4 ft)								2	
10 m (32.8 ft)								3	
Manual									
English									1

Accessories

Description	Part number
De-bubbler assembly	7997 500
Dry standard HIGH (for ISO infrared LED version)	7998 048
Dry standard LOW (for ISO infrared LED version)	7998 047



Our offering:

	Actuators and Positioners		Analytical Instruments
	Device Management, Fieldbus and Wireless		Flow Measurement
	Force Measurement		Level Measurement
	Natural Gas Measurement		Pressure Measurement
	Recorders and Controllers		Temperature Measurement

HMI – Automação e Instrumentação, Lda.

Rua dos 5 Caminhos, nº 570
4780-382 Santo Tirso
PORTUGAL

Tel. +351 252 850 501
Fax. +351 300 013 487

Web: www.hmi.pt

Email: hmi@hmi.pt

Contact us

ABB Limited

Process Automation

Oldends Lane
Stonehouse
Gloucestershire GL10 3TA
UK

Tel: +44 1453 826 661

Fax: +44 1453 829 671

ABB Inc.

Process Automation

125 E. County Line Road
Warminster
PA 18974
USA

Tel: +1 215 674 6000

Fax: +1 215 674 7183

www.abb.com

Note

We reserve the right to make technical changes or modify the contents of this document without prior notice. With regard to purchase orders, the agreed particulars shall prevail. ABB does not accept any responsibility whatsoever for potential errors or possible lack of information in this document.

We reserve all rights in this document and in the subject matter and illustrations contained therein. Any reproduction, disclosure to third parties or utilization of its contents in whole or in parts – is forbidden without prior written consent of ABB.

Copyright© 2014 ABB

All rights reserved